

Service
Service
Service



MCM530



MCM590

Service Manual

TABLE OF CONTENTS

	Page
Location of pc boards & Version variations	1-2
Technical Specifications	1-3
Measurement setup	1-4
Service Aids, Safety Instruction, etc.	1-5
Disassembly Instructions & Service positions	2
Service Test Programs	3-1
Set Block diagram	4-1
Set Wiring diagram	5-1
Front Board	6
ECO6 Tuner Board : Systems Non-Cenelec	7A
Systems Cenelec	7B
5DTC Module (MP3 Version)	10
Power 2003 Module (75 - 150W Class D)	11
Set Mechanical Exploded view & parts list	12



© Copyright 2003 Philips Consumer Electronics B.V. Eindhoven, The Netherlands
All rights reserved. No part of this publication may be reproduced, stored in a retrieval system or transmitted, in any form or by any means, electronic, mechanical, photocopying, or otherwise without the prior permission of Philips.

Published by SL 0406 Service Audio Printed in The Netherlands Subject to modification



3140 785 32900

Version 1.0



PHILIPS

SPECIFICATIONS**GENERAL:**

Mains voltage : 110-127V/220-240V Switchable for /21
 120V \pm 10% for /37
 230V \pm 10% for /22
 230-240V for /30

Mains frequency : 50/60Hz
 Clock accuracy : < 4 seconds per day
 Dimension centre unit : 175 x 268 x 316mm

Power consumption

Active : 60W for MCM530/22/30/37
 Active : 69W for MCM530/21
 Active : 110W for MCM590/21
 Standby : < 15W (DEMO mode off)
 ECO Power Standby : < 0.5W for /22/30/37
 ECO Power Standby : < 1W for /21

TUNER:**FM**

Tuning range : 87.5-108MHz
 Grid : 50kHz
 100kHz for /21/37

IF frequency : 10.7MHz \pm 25kHz
 Aerial input : 75 Ω coaxial
 300 Ω click fit for /37

Sensitivity at 26dB S/N : < 7 μ V
 Selectivity at 600kHz bandwidth : > 25dB
 Image rejection : > 25dB [> 75dB]
 Distortion at RF=1mV, dev. 75kHz : < 3%
 -3dB Limiting point : < 8 μ V
 Crosstalk at RF=1mV, dev. 40kHz : > 18dB

MW

Tuning range : 531-1602kHz
 530-1700kHz for /21/37

Grid : 9kHz
 10kHz for /21/37

IF frequency : 450kHz \pm 1kHz
 Aerial input : Frame aerial

Sensitivity at 26dB S/N : < 4.4mV/M
 Selectivity at 18kHz bandwidth : > 18dB
 IF rejection : > 45dB
 Image rejection : > 28dB
 Distortion at RF=50mV, M=80% : < 5%

AMPLIFIER:**Output power**

L & R : 2 x 75W RMS (6 Ω , 1kHz, 10% THD)
 : 2 x 125W RMS (4 Ω , 1kHz, 10% THD)
 for MCM590/21

Output power (6 Ω , 60Hz-12.5kHz, 10% THD)

L & R : 2 x 70W FTC for MCM530/37

Frequency response within -3dB : 50Hz-16kHz
 MAX Sound : On / Off
 Digital Sound Control (DSC) : Jazz / Rock / Pop / Optimal
 Virtual Environment Control (VEC) : Cyber Hall / Concert /
 Cinema / Off

Input sensitivity

Aux in (at 1kHz) : 500mV at 600 Ω
 CDR in (at 1kHz) : 1000mV at 600 Ω
 USB (at 1kHz) : 830mV at 600 Ω

Output sensitivity

Headphone output at 32 ohm : 15mW \pm 2dB (Max. vol.)

5DTC:

Measurement done directly at the connector on the board.

Output Resistance : < 100 Ω
 Output Voltage (0dB, 1kHz) : 0.5Vrms \pm 1dB (unloaded)
 Channel Unbalance : < \pm 1dB
 Channel Separation (1kHz) : > 60dB
 Frequency Response (\pm 3dB) : 20Hz-20kHz
 Signal to Noise Ratio : > 76dBA
 MP3-CD Bit Rate : 32-256 kbps
 Sampling Frequencies : 32, 44.1, 48 kHz

USB:

Measurement done directly at the connector on the board.

Output Resistance : < 1.5 k Ω
 Output Voltage (0dB, 1kHz) : 830mVrms \pm 1.5dB
 ($R_L = 33$ kohm)
 Channel Unbalance : < \pm 1dB
 THD + Noise (0dB, 1kHz) : < 0.3%
 Channel Separation (0dB, 1kHz) : > 40dB
 Frequency Response (\pm 3dB) : 20Hz-20kHz
 Signal to Noise Ratio : > 75dBA

[...] Values indicated are for "ECO6 Cenelec Board" only.

MEASUREMENT SETUP

Tuner FM

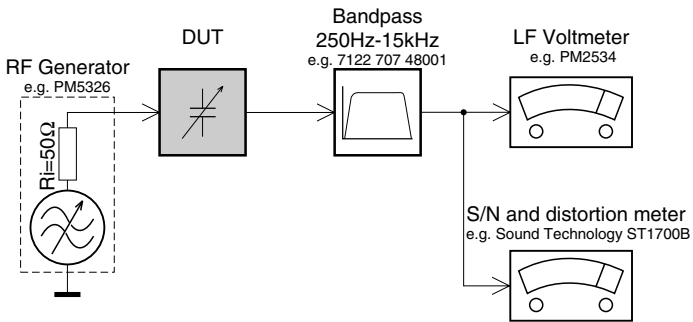

Use a bandpass filter to eliminate hum (50Hz, 100Hz) and disturbance from the pilotone (19kHz, 38kHz).

Tuner AM (MW,LW)

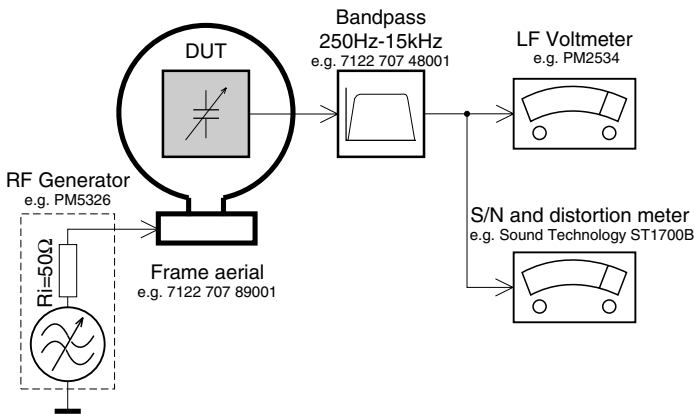

To avoid atmospheric interference all AM-measurements have to be carried out in a Faraday's cage.
Use a bandpass filter (or at least a high pass filter with 250Hz) to eliminate hum (50Hz, 100Hz).

CD

Use Audio Signal Disc SBC429 4822 397 30184
(replaces test disc 3)

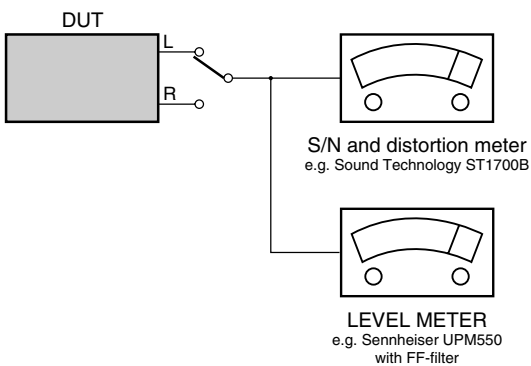

Recorder

Use Universal Test Cassette **CrO2** SBC419 4822 397 30069
or Universal Test Cassette **Fe** SBC420 4822 397 30071

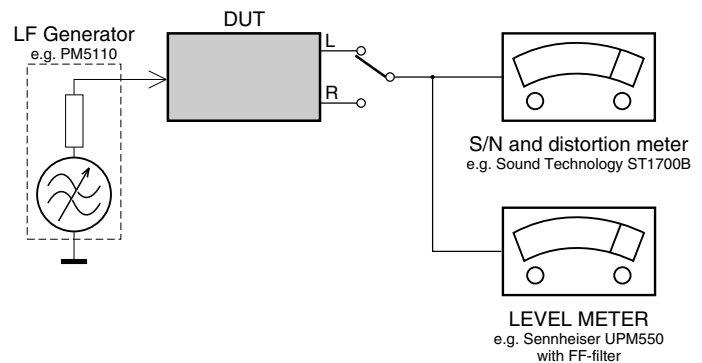

SERVICE AIDS

Service Tools:

Universal Torx driver holder	4822 395 91019
Torx bit T10 150mm	4822 395 50456
Torx driver set T6 - T20	4822 395 50145
Torx driver T10 extended	4822 395 50423

Cassette:

SBC419 Test cassette CrO2	4822 397 30069
SBC420 Test cassette Fe	4822 397 30071
MTT150 Dolby level 200nWb/M	4822 397 30271

Compact Disc:

SBC426/426A Test disc 5 + 5A	4822 397 30096
SBC442 Audio Burn-in Test disc 1kHz	4822 397 30155
SBC429 Audio Signals disc	4822 397 30184
Dolby Pro-logic Test Disc	4822 395 10216

ESD Equipment:

Anti-static table mat - large 1200x650x1.25mm ...	4822 466 10953
Anti-static table mat - small 600x650x1.25mm	4822 466 10958
Anti-static wristband	4822 395 10223
Connector box (1M Ω)	4822 320 11307
Extension cable (to connect wristband to conn. box)	4822 320 11305
Connecting cable (to connect table mat to conn. box)	4822 320 11306
Earth cable (to connect product to mat or box)	4822 320 11308
Complete kit ESD3 (combining all above products)	4822 320 10671
Wristband tester	4822 344 13999

HANDLING CHIP COMPONENTS

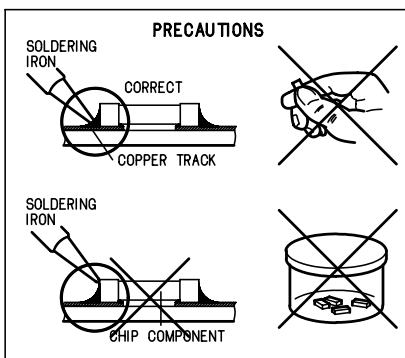
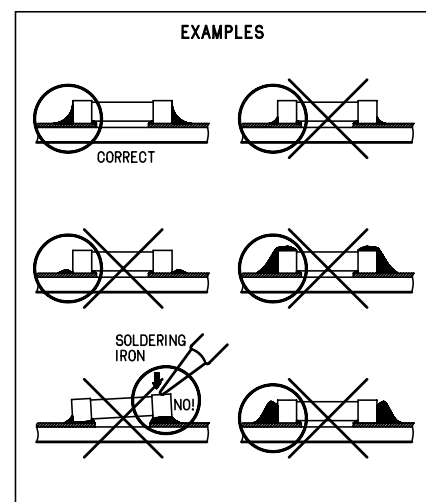
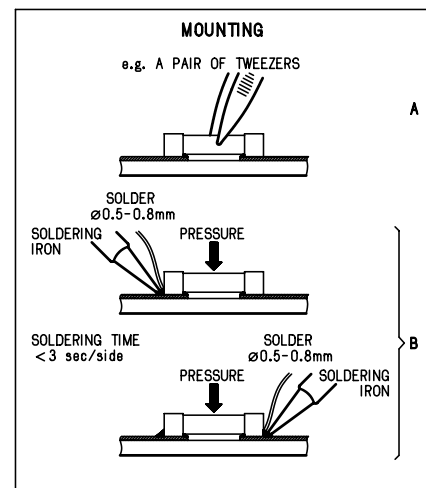
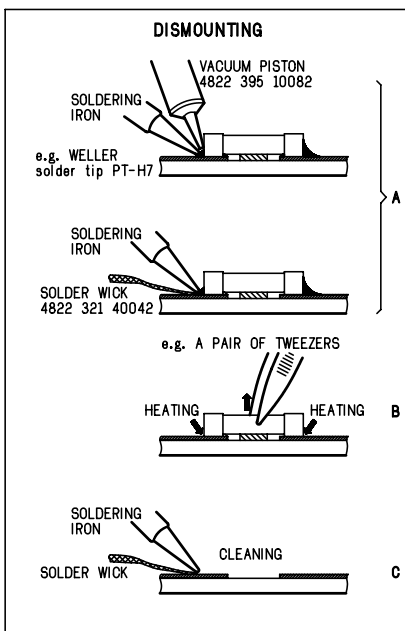
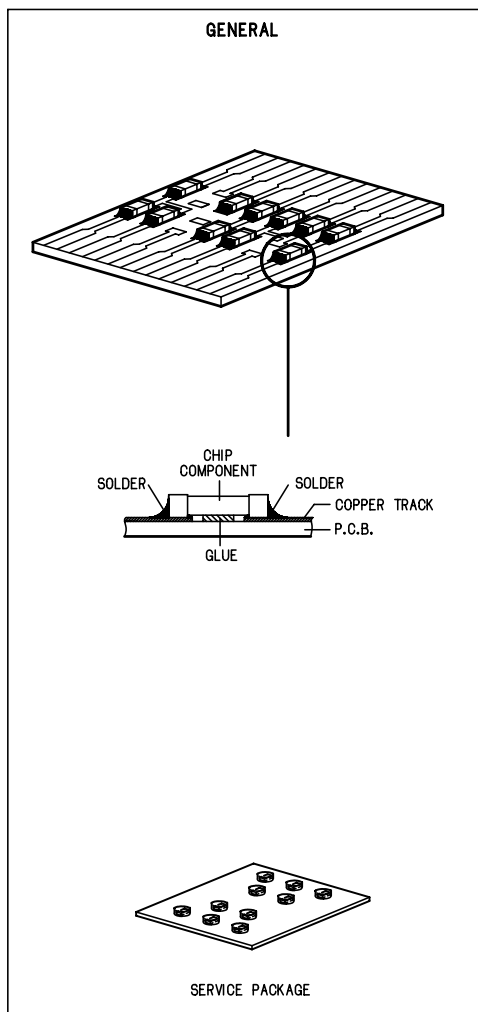

(GB) WARNING

All ICs and many other semi-conductors are susceptible to electrostatic discharges (ESD). Careless handling during repair can reduce life drastically.

When repairing, make sure that you are connected with the same potential as the mass of the set via a wrist wrap with resistance. Keep components and tools also at this potential.

(F) ATTENTION

Tous les IC et beaucoup d'autres semi-conducteurs sont sensibles aux décharges statiques (ESD).

Leur longévité pourrait être considérablement écourtée par le fait qu'aucune précaution n'est prise à leur manipulation.

Lors de réparations, s'assurer de bien être relié au même potentiel que la masse de l'appareil et enfiler le bracelet serti d'une résistance de sécurité.

Veiller à ce que les composants ainsi que les outils que l'on utilise soient également à ce potentiel.

(GB)

Safety regulations require that the set be restored to its original condition and that parts which are identical with those specified, be used.

(NL)

Veiligheidsbepalingen vereisen, dat het apparaat bij reparatie in zijn oorspronkelijke toestand wordt teruggebracht en dat onderdelen, identiek aan de gespecificeerde, worden toegepast.

(F)

Les normes de sécurité exigent que l'appareil soit remis à l'état d'origine et que soient utilisées les pièces de rechange identiques à celles spécifiées.

(D)

Bei jeder Reparatur sind die geltenden Sicherheitsvorschriften zu beachten. Der Originalzustand des Geräts darf nicht verändert werden; für Reparaturen sind Original-Ersatzteile zu verwenden.

(I)

Le norme di sicurezza esigono che l'apparecchio venga rimesso nelle condizioni originali e che siano utilizzati i pezzi di ricambio identici a quelli specificati.

"After servicing and before returning set to customer perform a leakage current measurement test from all exposed metal parts to earth ground to assure no shock hazard exist. The leakage current must not exceed 0.5mA."

ESD**(D) WARNUNG**

Alle ICs und viele andere Halbleiter sind empfindlich gegenüber elektrostatischen Entladungen (ESD).

Unvorsichtige Behandlung im Reparaturfall kann die Lebensdauer drastisch reduzieren.

Veranlassen Sie, dass Sie im Reparaturfall über ein Pulsarmband mit Widerstand verbunden sind mit dem gleichen Potential wie die Masse des Gerätes.

Bauteile und Hilfsmittel auch auf dieses gleiche Potential halten.

(NL) WAARSCHUWING

Alle IC's en vele andere halfgeleiders zijn gevoelig voor electrostatische ontladingen (ESD).

Onzorgvuldig behandelen tijdens reparatie kan de levensduur drastisch doen verminderen. Zorg ervoor dat u tijdens reparatie via een polsband met weerstand verbonden bent met hetzelfde potentiaal als de massa van het apparaat.

Houd componenten en hulpmiddelen ook op ditzelfde potentiaal.

(I) AVVERTIMENTO

Tutti IC e parecchi semi-conduttori sono sensibili alle scariche statiche (ESD).

La loro longevità potrebbe essere fortemente ridotta in caso di non osservazione della più grande cauzione alla loro manipolazione.

Durante le riparazioni occorre quindi essere collegato allo stesso potenziale che quello della massa dell'apparecchio tramite un braccialetto a resistenza.

Assicurarsi che i componenti e anche gli utensili con quali si lavora siano anche a questo potenziale.

"Pour votre sécurité, ces documents doivent être utilisés par des spécialistes agréés, seuls habilités à réparer votre appareil en panne".

**(GB) Warning !**

Invisible laser radiation when open.
Avoid direct exposure to beam.

(S) Varning !

Osynlig laserstrålning när apparaten är öppnad och spärren är urkopplad. Betrakta ej strålen.

(SF) Varoitus !

Avatussa laitteessa ja suojalukituksen ohitettaessa olet alltiina näkymättömälle laserisäteilylle. Älä katso säteeseen!

(DK) Advarse !

Usynlig laserstråling ved åbning når sikkerhedsafbrydere er ude af funktion. Undgå udsættelse for stråling.

Connections

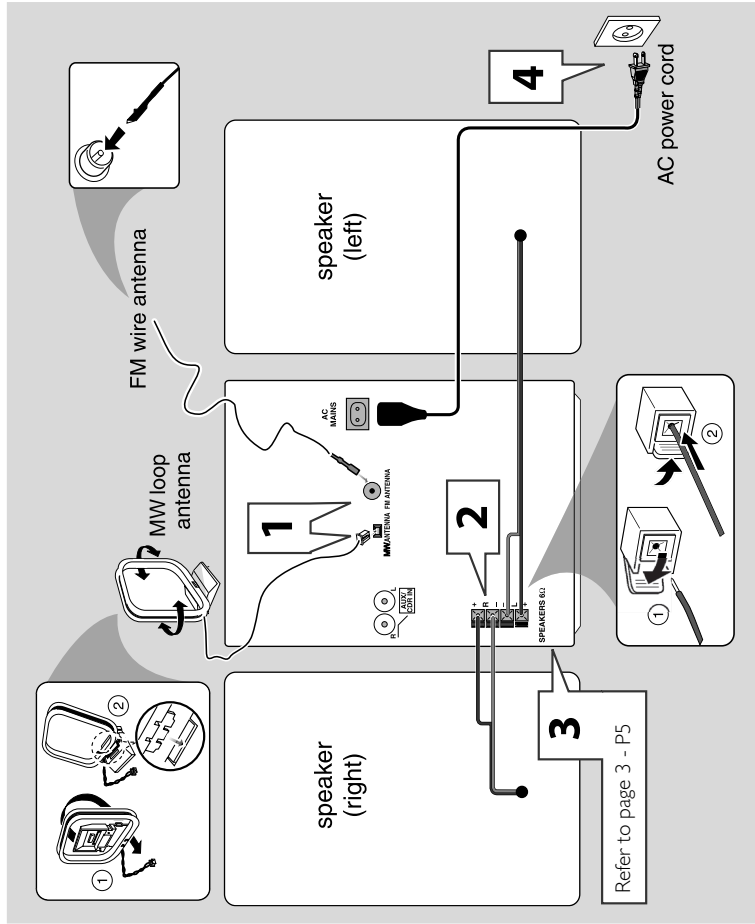

WARNING!

- Use only the supplied speakers. The combination of the main unit and speakers provides the best sound. Using other speakers can damage the unit and sound quality will be negatively affected.
- Never make or change connections with the power switched on.
- Connect the AC power cord to the power outlet only after you have finished hooking up everything.
- To avoid overheating of the system, a safety circuit has been built in. Therefore, your system may switch to Standby mode automatically under extreme conditions. If this happens, let the system cool down before reusing it (not available for all versions).

Step 1: Connecting FM/MW antennas

- Place the MW loop antenna on a shelf or attach it to a stand or wall.
- Extend the FM antenna and fix its ends to the wall.
- Adjust the position of the antennas for optimal reception.
- Position the antennas as far as possible from a TV, VCR or other radiation source to prevent unwanted noise.
- For better FM stereo reception, connect external FM antenna.

Step 2: Connecting the speakers

Connect the speaker wires to the SPEAKERS terminals, right speaker to "R" and left speaker to "L", coloured (marked) wire to "+" and black (unmarked) wire to "-". Fully insert the stripped portion of the speaker wire into the terminal as shown.

Notes:

- Ensure that the speaker cables are correctly connected. Improper connections may damage the system due to short-circuit.
- Do not connect more than one speaker to any one pair of + / - speaker terminals.

Step 3: Connecting to PC

Use the supplied USB cable to connect the system to your personal computer's USB port. After installed the USB PC LINK application software onto your PC, you are able to playback your music collection via the system (refer to "USB PC Link").

Connections

Step 5: Inserting batteries into the remote control

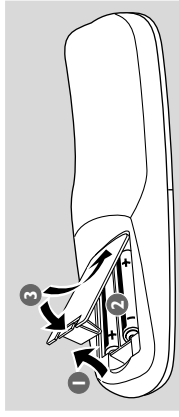

- 1 Open the battery compartment cover.
- 2 Insert two batteries type R06 or AA, following the indications (+ -) inside the compartment.
- 3 Close the cover.

Using the remote control to operate the system

- 1 Aim the remote control directly at the remote sensor (IR) on the main unit.
- 2 Select the source you wish to control by pressing one of the source select keys on the remote control (for example CD, TUNER).
- 3 Then select the desired function (for example ▶ II, ◀, ▶).

CAUTION!

- Remove batteries if they are exhausted or will not be used for a long time.
- Do not use old and new or different types of batteries in combination.
- Batteries contain chemical substances, so they should be disposed of properly.

Step 4: Connecting the AC power cord

"AUTO INSTALL - PRESS PLAY" may appear on the display panel when the AC power cord is plugged into the power outlet for the first time. Press ▶ II on the main unit to store all available radio stations (page 3 - P3) or press ■ to exit (refer to "Tuner Operations").

Timer Operations

Temporarily deactivating the wake up timer

You are only able to activate the Snooze function within 30 minutes after the timer wakes up from standby mode.

- 1 After timer wake up, press **SNOOZE** on the remote.
The system will switch to standby mode for five minutes. After that, it resumes the last selected source again.
- 2 To cancel the snooze function, press **SNOOZE** again.

Sleep timer setting

The sleep timer turns the system to Eco Power standby mode at a preselected time.

- 1 Press **SLEEP** repeatedly until it reaches the desired preset turn-off time.
The selections are as follows (time in minutes):
15 → 30 → 45 → 60 → 90 → 120 → OFF → 15 ...
SLEEP is shown, except for "OFF" mode.
To view or change the setting, repeat the above.
 - 2 Before the system switches to Eco Power standby mode, a countdown of 10 seconds is displayed.
"SLEEP 10" → "SLEEP 9" ... → "SLEEP 1" → "SLEEP"
- To cancel the sleep timer**
Press **SLEEP** repeatedly until "OFF" is displayed, or press the **STANDBY ON** button.

Other Connection

Listening to an external source

You can listen to the sound of the connected external device through your system's speakers.

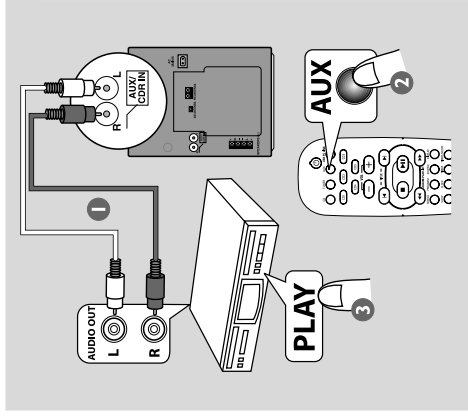

- 1 Use the red / white audio cables to connect to the system's **AUX/CDR IN (RL)** terminals to the **AUDIO OUT** terminals on the other audio/visual device (such as TV,VCR, Laser Disc player, DVD player or CD recorder)
If the connecting device has only a single audio out terminal, connect it to the **AUX/CDR IN** left terminal. Alternatively, you can use a "single to double" cinch cable, but the output sounds still remain mono.
 - 2 Press **AUX** repeatedly.
Select "FLU," when connecting to a TV, VCR or Laser Disc player.
Select "FLU,"/E, JFF", when connecting to a CD recorder or DVD player.
 - 3 Press **PLAY** on the connected device to start playback.
- Notes:**
– All the sound control features (DSC, VEC for example) are available for selection.
– Always refer to the owner's manual of the other equipment for complete connection and use details.

Italia

DICHIARAZIONE DI CONFORMITA'

Si dichiara che l'apparecchio MC M530, Philips risponde alle prescrizioni dell'art. 2 comma 1 del D.M. 28 Agosto 1995 n. 548.

Fatto a Eindhoven

Philips Consumer Electronics
Philips, Glaslaan 2
56116 JB Eindhoven, The Netherlands

Norge

Typeskilt finnes på apparatens underside.

Observer: Nettbryteren er sekundert innkoplet. Den innebygde nettdelen er derfor ikke frakoplet nettet så lenge apparatet er tilsluttet nettkontaktten.

For å redusere faren for brann eller elektrisk støt, skal apparatet ikke utsettes for regn eller fuktighet.

CAUTION

Use of controls or adjustment or performance of procedures other than herein may result in hazardous radiation exposure or other unsafe operation.

VAROITUS

Muiden kuin tässä esitettyjen toimintojen säädön tai asetusten muutto saattaa alistaa vaaralliselle säteilylle tai muille vaarallisille toiminnoille.

Important notes for users in the U.K.

Mains plug

This apparatus is fitted with an approved 13 Amp plug. To change a fuse in this type of plug proceed as follows:

- 1 Remove fuse cover and fuse.
- 2 Fix new fuse which should be a BS1362 5 Amp, A.S.T.A. or BSI approved type.
- 3 Refit the fuse cover.

If the fitted plug is not suitable for your socket outlets, it should be cut off and an appropriate plug fitted in its place.

If the mains plug contains a fuse, this should have a value of 5 Amp. If a plug without a fuse is used, the fuse at the distribution board should not be greater than 5 Amp.

Note: The severed plug must be disposed of to avoid a possible shock hazard should it be inserted into a 13 Amp socket elsewhere.

How to connect a plug

The wires in the mains lead are coloured with the following code: blue = neutral (N), brown = live (L).

- As these colours may not correspond with the colour markings identifying the terminals in your plug, proceed as follows:
 - Connect the blue wire to the terminal marked N or coloured black.
 - Connect the brown wire to the terminal marked L or coloured red.
 - Do not connect either wire to the earth terminal in the plug, marked E (or ⊕) or coloured green (or green and yellow).

Before replacing the plug cover, make certain that the cord grip is clamped over the sheath of the lead - not simply over the two wires.

Copyright in the U.K.

Recording and playback of material may require consent. See Copyright Act 1956 and The Performer's Protection Acts 1958 to 1972.

Functional Overview

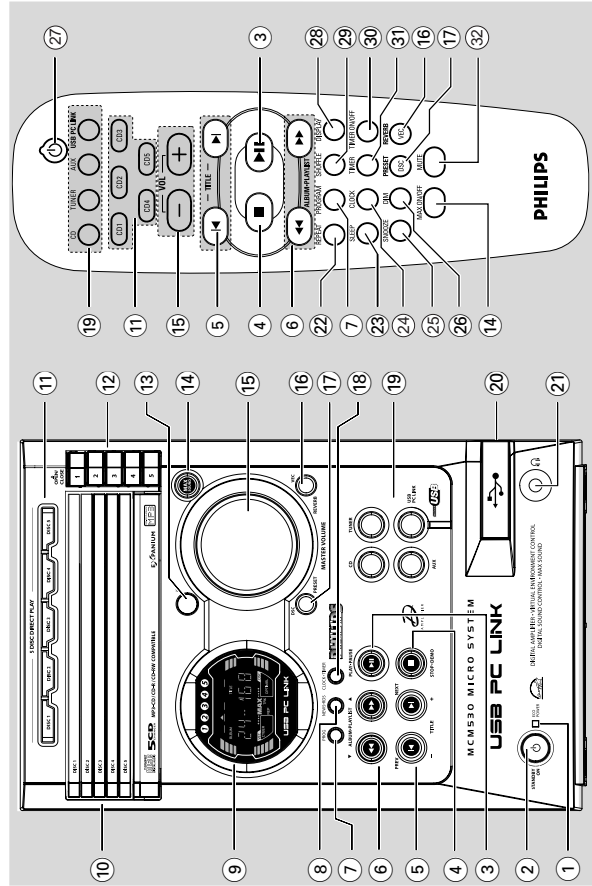

Main unit and remote control

- ① **ECO POWER indicator**
 - Lights up when the system is in Eco Power standby mode.
- ② **STANDBY ON**
 - Switches to Eco Power standby mode or turns on the system.
 - *Switches to standby mode.
- ③ **PLAY•PAUSE ► II**
 - CD: starts/pauses playback.
 - USB PC LINK: starts/pauses playback.
 - (only on the main unit)
 - TUNER: *enters Plug & Play tuner installation mode and/or starts preset radio station installation.
- ④ **STOP•DEMO ■**
 - Exits an operation.
 - CD: stops playback or clears a programme.
 - TUNER: *erases a preset radio station.
 - USB PC LINK: stops playback.
 - (only on the main unit)
 - *Turns on/off the demonstration mode.
- ⑤ **PREV ◀ / NEXT ▶ (— TITLE +)**
 - CD: selects a track.
 - MP3-CD: select a title
 - TUNER: selects a preset radio station.
 - CLOCK: sets the minutes.
 - USB PC LINK: selects a track from the playlist.
- ⑥ **◀◀ ALBUM•PLAYLIST ▶▶**
 - CD: *searches backward/forward.
 - MP3-CD: select an album
 - TUNER: tunes the radio frequency up/down.
 - CLOCK: sets the hours.
 - USB PC LINK: selects a playlist.
- ⑦ **PROG (PROGRAM)**
 - CD: starts or confirms track programming.
 - TUNER: starts *automatic/manual preset programming.
 - CLOCK: selects 12- or 24-hour clock display
- ⑧ **NEWS•RDS**
 - In tuner mode, selects RDS information.
 - In other modes, turns on/off news.
- ⑨ **Display screen**

* = Press and hold the button for more than two seconds.

Functional Overview

- ⑩ **Disc trays (1~5)**
- ⑪ **5 DISC 1~5 (CD 1~5)**
 - Selects a disc tray to playback.
- ⑫ **OPEN/CLOSE ▲ 1~5**
 - Opens/closes the individual disc tray.
- ⑬ **IR**
 - Point the remote control towards this sensor.
- ⑭ **MAX SOUND (MAX ON/OFF)**
 - Turns on/off the optimal mix of various sound features.
- ⑮ **MASTER VOLUME (VOL + -)**
 - Adjusts the volume level.
- ⑯ **VEC/ REVERB**
 - Selects different type of ambience-based equaliser settings (HALL, CINEMA, CONCERT, CYBER or ARCADE).
- ⑰ **DSC/ PRESET**
 - Selects different types of preset sound equaliser settings (OPTIMAL, JAZZ, ROCK or POP).
 - PRESET and REVERB environment sound modes are only available when the optional software, Philips Sound Agent 2 is activated during USB PC Link application.
- ⑱ **CLOCK•TIMER**
 - *Enters clock or timer setting mode.
 - Switches to clock display mode.
- ⑲ **CD / TUNER / AUX / USB PC LINK**
 - Selects the relevant active mode.
 - CD: toggles between DISC 1~5.
 - TUNER: toggles between FM and MW band.
 - AUX: toggles between AUX and CDR mode.
 - USB PC Link: Selects USB PC Link source.
 - Connect the USB cable between the system and PC's USB port.
- ⑲ **Ⓜ**
 - Plug in the headphones jack. The speakers output will be cancelled.

Control buttons available on the remote control only

- ⑳ **REPEAT**
 - Repeats a track/disc/all programmed tracks.
- ㉑ **SLEEP**
 - Sets the sleep timer function.
- ㉒ **CLOCK**
 - *Enters clock setting mode.
 - Switches to clock display mode.
- ㉓ **SNOOZE**
 - Temporarily deactivate the wake up timer.
- ㉔ **DIM**
 - Selects different levels of brightness for display panel.
 - Switches to Eco Power standby mode.
 - *Switches to standby mode.
- ㉕ **DISPLAY**
 - Displays the album and title name for MP3 disc.
- ㉖ **SHUFFLE**
 - Turns on/off the random play mode.
- ㉗ **TIMER ON/OFF**
 - Turns on/off timer function.
- ㉘ **TIMER**
 - *Enters the timer setting mode.
 - Displays the timer setting.
- ㉙ **MUTE**
 - Mutes or restores the volume.

IMPORTANT!

- Make sure the mute setting on your PC control panel is deactivated to ensure you get the sound from your audio system!

Quick setup guide

PC system requirement

- Windows 98SE/ME/2000/XP
- Intel Pentium MMX200 or higher
- CD-ROM drive
- USB port
- Free hard disk space: 80 MB for the software

Software installation

- 1 Turn on your PC and insert the installer disc into your PC's CD-ROM drive.
- 2 The installation guide will appear automatically. If it does not, go to the CD-ROM drive in Windows Explorer and double click the **Setup.exe**.
- 3 Select your desired language from the list.
- 4 Select **Install Software**.
- 5 Connect the USB cable to the PC and Audio System and press the USB PC Link button on the Audio set or the remote control.
- 6 Follow the instructions as prompted on the screen to correctly install the USB PC Link Driver, **Philips Sound Agent 2** and **MusicMatch Jukebox** software.

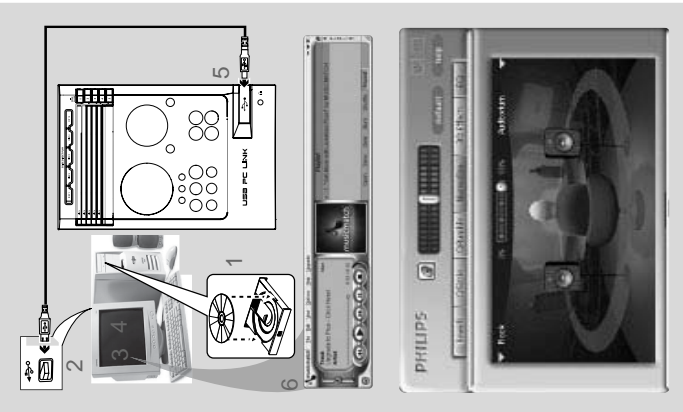

Declarations

Windows and **Pentium** are trademarks of Microsoft Corporation and Intel Corporation. All other trademarks belong to their respective owners.
 USB PC Link sample track, music by Chemistry (www.chemistryteam.com)

Notes:

- Minimum OS requirement for **Philips Sound Agent 2: Windows 2000 or XP**.
- During installation, your previous **MusicMatch Jukebox software on your PC will be replaced**.

Using MusicMatch software

To create a music library

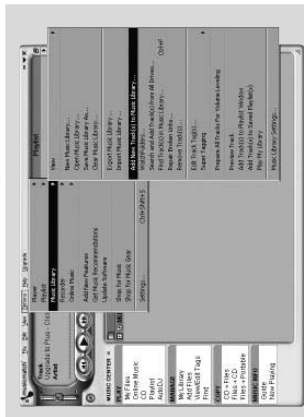

Add music files to **My Music Library**

- 1 Add files to **My Library** by dragging and dropping audio tracks from anywhere in Windows, into the **My Library** window. You can also click **Add Files** in the **Music Center** to add tracks.
 - 2 Click the **Add Files** button on the **Music Library** window.
 - 3 Browse your computer to the folder where audio files are stored. Check the box **Also Add Tracks** from Subfolders to add all tracks in the current folder, and all subfolders.
 - 4 Click the **Select All** button to select all the files in the current, and all subfolders.
- Files will be added to **My Library**.
 To create a **"Playlist"**

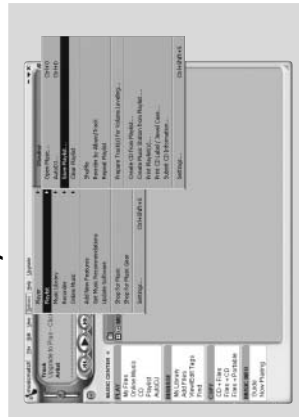

- 1 Drag and drop files, or folders with music files, from anywhere on your computer or **My Library** into the **Playlist** window. Your files will begin to play. Or, you may click the **Open** button on the **Playlist** window to browse for and add music to the **Playlist**.

- 2 Click the **Save** button on the **Playlist**, or go to the menu **Options > Playlist > Save Playlist**. You will be prompted to name the **Playlist**. In the Name field type the name you'd like to give this **Playlist**.

- 4 Click the **Save** button. Now you can play all the saved playlists with the audio system by pressing **◀** or **▶** buttons. Details operation, please refer to Connecting to **USB PC Link**.

Note:

- It is not possible to create a playlist from the system's 5 CD changer. If you encounter any problem using **USB PC Link**, please refer to the **FAQ** (Frequently Asked Questions) stored in your **USB PC Link installer disc** or visit "www.audio.philips.com" for the latest update on **FAQ**.

Connecting to USB PC Link

USB PC Link allows you to playback your music collection from the PC via the powerful amplifier and speakers of this system.

IMPORTANT!

Make sure the MUSICMATCH software has been installed. Refer to the CD-ROM sleeve for USB PC Link installation.

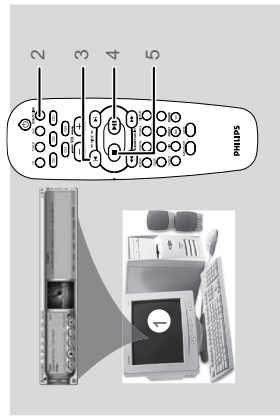

- 1 Turn on your computer and launch the **"MUSICMATCH JUKEBOX"**.
 The volume level of PC should not be put into mute.
- 2 Press **USB PC LINK**.
 If the audio streaming is detected, **"CONNECTING"** is displayed and the USB indicator will be flashing.
 If **"NO CONNECTION"** is displayed, check the connection between your PC and micro system.

USB PC Link

Notes:

– When the USB PC Link feature is activated, Philips Sound Agent 2 will automatically be launched (if it has been successfully installed under OS Windows 2000/XP).

– The default setting for PRESET/REVERB is MP3/Study Room respectively. You may select from the list of different sound modes to suit your music and environment preference. Alternatively, you may select PRESET (Neutral mode) and REVERB (No Environment mode) for the minimum sound effect.

3 Press ◀◀ or ▶▶ to select your favorite playlist, and then press ◀◀ or ▶▶ until the desired track in the playlist is highlighted.

4 Press ▶ III to start playback.

The track information will appear on the display. The display only supports English characters.

During playback,

– Press **SHUFFLE** to play all available tracks in the playlist in random order.

– Press **REPEAT** to repeat playback of all the tracks in the playlist.

5 To exit, select another active mode or press ■.

Philips Sound Agent 2

Philips Sound Agent 2 is a BONUS software provided with Philips Audio system to enhance the quality of MP3 Music playback via USB PC Link.

1 **Philips Sound Agent 2** will be automatically launched if USB PC Link is selected.

2 Press **DSC/PRESET** or **VEC/REVERB** to select different Preset or Reverb sound effect.

3 For more details about using **Philips Sound Agent 2** features on your PC, please refer to the User Manual in the supplied CD-ROM or the Help menu.

Notes:

– **Philips Sound Agent 2 minimum OS requirement: Windows 2000 or XP.**

– Please refer to the CD-ROM sleeve for detailed installation procedures, OR 'Software installation' in this manual.

Enabling digital CD audio output

Before playing the CD through your PC's CD-ROM drive, it is necessary to configure your PC's hardware as follows:

For Windows ME / 2000 / XP

1 Enter the system control panel menu and select:

"System → Hardware → Device Manager → CD-ROM drives → Action-Properties → Properties".

OR

For Windows 98SE

Enter the system control panel menu and select: "MULTIMEDIA" and "CD MUSIC".

2 Check the 'Enable digital CD audio for this CD-ROM device' setting option is selected (enabled).

Notes:

– You may need to refer to your PC's manual for correct configuration.

– For the optimal playback effect of the CD/MP3-CD, please use your Philips audio system.

WARNING

Under no circumstances should you try to repair the system yourself, as this will invalidate the warranty. Do not open the system as there is a risk of electric shock.

If a fault occurs, first check the points listed below before taking the system for repair. If you are unable to remedy a problem by following these hints, consult your dealer or Philips for help.

Problem	Solution
<p>Auto Installation of the Installer CD-ROM did not install the Philips Sound Agent 2 onto my PC.</p>	<p>Check that your PC's Operating System is running on Windows 2000/XP.</p>
<p>When in USB PC LINK mode, "NO CONNECTION" is displayed.</p>	<p>Check the connection between your PC and the system and the initial setup required, see "Connections" and "USB PC Link". Make sure the connected PC is turned on. Select the PRESET - Neutral mode. Select the REVERB - No environment mode.</p>
<p>I want the minimum effect from the Philips Sound Agent 2 sound mode when listening to MP3 music streaming via USB PC Link.</p>	<p>If the signal is too weak, adjust the antenna or connect an external antenna for better reception. Increase the distance between the system and your TV or VCR.</p>
<p>Radio reception is poor.</p>	<p>Insert a disc. Load in the disc with label facing right. Replace or clean the disc, see "Care and safety information". Use a finalised CD-R(W) or a correct format disc.</p>
<p>"NO DISC" is displayed or the disc cannot be played.</p>	<p>Remove and reconnect the AC power cord and switch on the system again.</p>
<p>The system does not react when buttons are pressed.</p>	<p>Adjust the volume. Disconnect the headphones. Check that the speakers are connected correctly. Check that the AC power cord is connected properly. When in USB PC LINK mode, check that the PC's volume is not put into mute. When playing CD from PC's CD drive, refer to "USB PC Link – Enable digital CD audio output".</p>
<p>Sound cannot be heard or is of poor quality.</p>	<p>Select the source (CD or TUNER, for example) before pressing the function button (▶◀, ◀▶, ▶▶). Reduce the distance between the remote control and the system. Replace the battery. Point the remote control directly toward the IR sensor.</p>
<p>The remote control does not function properly.</p>	<p>Set the clock correctly. Press TIMER ON/OFF to switch on the timer. Press and hold DEMO STOP on the main unit to switch off the demonstration mode.</p>
<p>The timer is not working.</p>	
<p>The system displays features automatically and buttons start flashing.</p>	

Problem	Solution
<p>The timer is not working.</p>	<p>Set the clock correctly. Press TIMER ON/OFF to switch on the timer.</p>
<p>The system displays features automatically and buttons start flashing.</p>	<p>Press and hold STOP DEMO on the main unit to switch off the demonstration mode.</p>
	<p>Refer to the FAQ (Frequently Asked Questions) on the supplied CD-ROM or visit our website "www.audio.philips.com" for latest update on FAQ.</p>

DISMANTLING INSTRUCTIONS

Dismantling of the 5DTC Module

- 1) Loosen 4 screws and remove the Cover Top (pos 255) by sliding it out towards the rear before lifting up.
 - 2 screws on the rear
 - 1 screw each on the left & right side
- 2) Loosen 3 screws each to remove the Panel Left (pos 253) and Panel Right (pos 254). The Panels are removed by sliding it towards the rear and outwards.
 - 1 screw on the side
 - 2 screws on the rear
- 3) Take a paper clip or any stiff wire diameter of 1mm-1.5mm. Place the set in position and insert the paper clip or stiff wire as shown in Figure 1.
- 4) To remove the Cover CD Orn (pos 111), you have to feel and give a push in the correct direction (see Figure 1) and correct position (see Figure 2) to release the catch of the Cover CD Orn before removing it out.
- 5) Loosen 4 screws A (see Figure 3 and Figure 9) to remove the 5DTC Module (pos 1103).
 - 2 screws on the front
 - 2 screws on the rear

Note : For information on the 'Emergency opening of the trays' of the 5DTC Module, refer to Chapter 10 (Page 10-7).

Figure 1

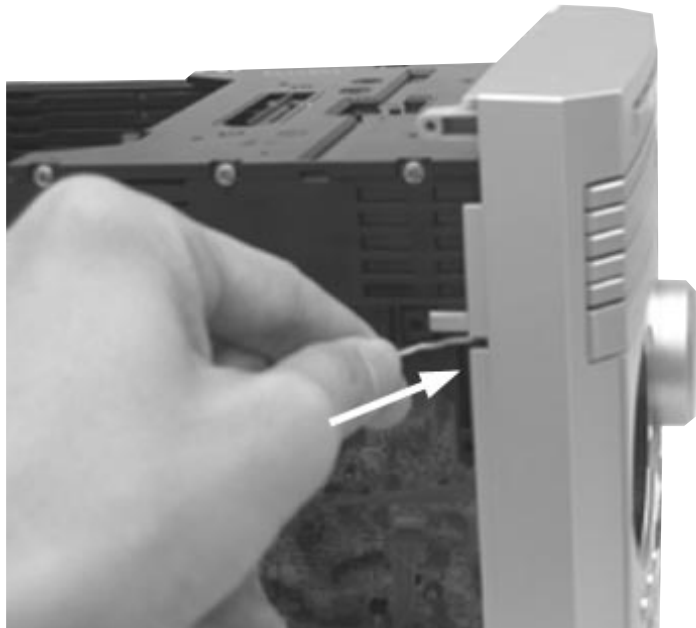

Figure 2

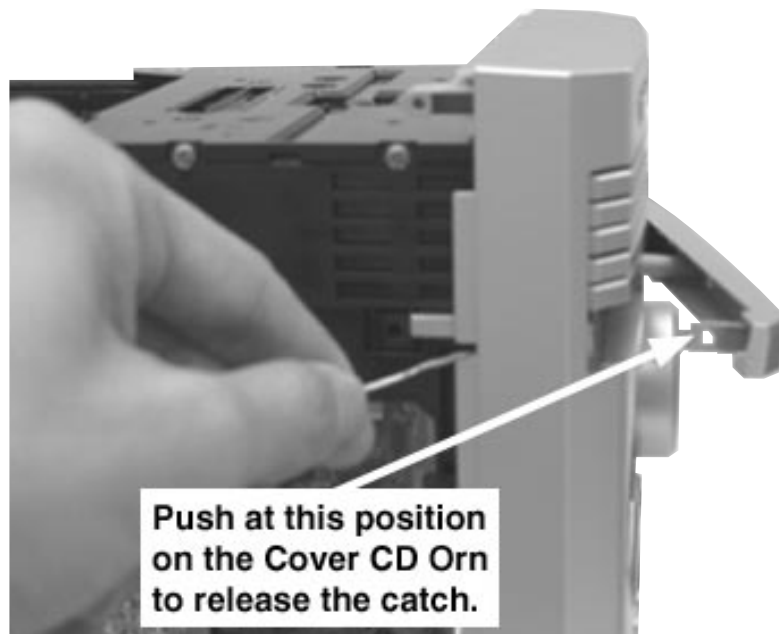
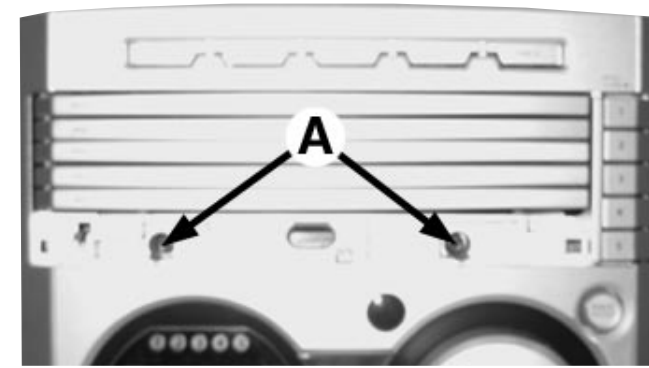

Figure 3



Detaching the Front Panel assembly from the Bottom/Rear assembly

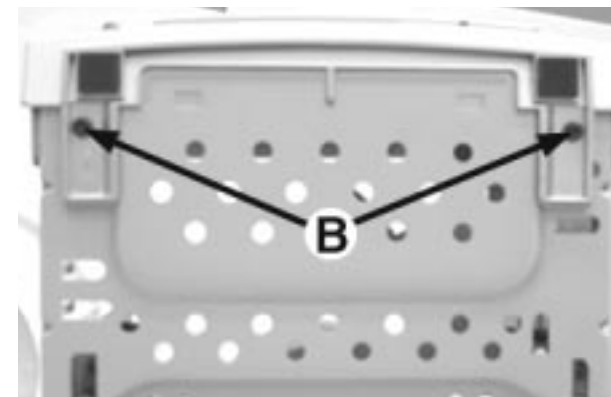

Figure 4

- 1) Remove 2 screws B (pos 282) as shown in Figure 4 from the bottom of the Cabinet Front (pos 101).
- 2) Release the fixation of the Combi Board (pos 1102-1001) to Bracket Combi (pos 252) by releasing the 2 catches C1 (see Figure 5) and pulling the Combi Board outwards as shown in Figure 6.
- 3) Uncatch 2 catches C2 (see Figure 5) on the left & right sides of the Cabinet Front (pos 101) and slides the Front Panel assembly out towards the front.

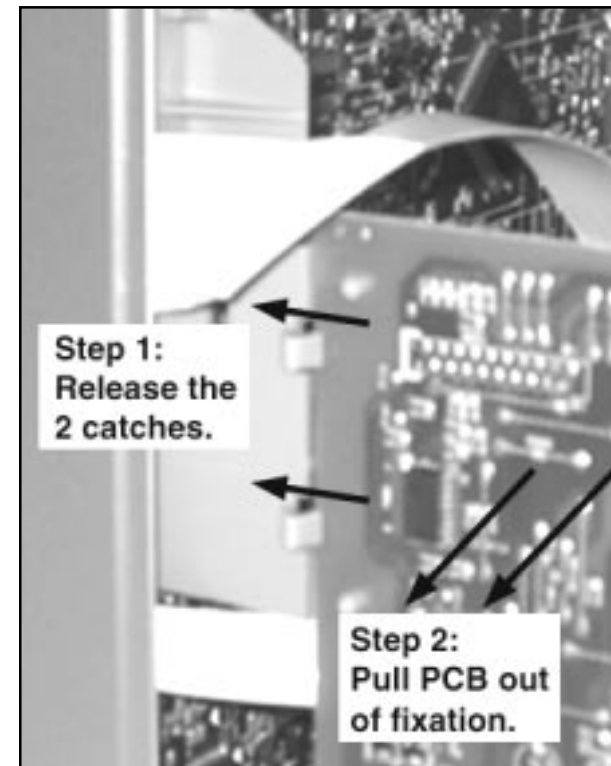

Figure 6

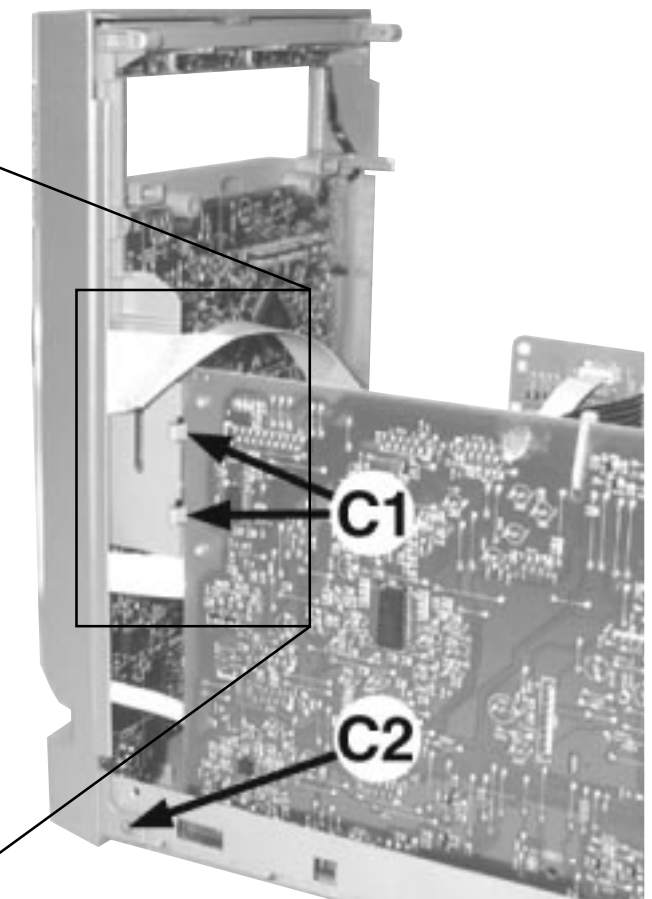

Figure 5

DISMANTLING INSTRUCTIONS

Dismantling of the Front Panel assembly

- 1) The Knob Volume (pos 136) can be removed by pulling it out in the direction as shown in Figure 7.
- 2) Loosen 4 screws D (see Figure 8) to remove the Bracket Top (pos 251) and CDC Key Board (pos 1105B).
- 3) Loosen 2 screws E (see Figure 8) to remove the Bracket Combi (pos 252).
- 4) Loosen 9 screws F (see Figure 8) to remove the Front Board (pos 1105A).
- 5) Loosen 3 screws G (see Figure 8) to remove the USB PC LINK Board (pos 1106).

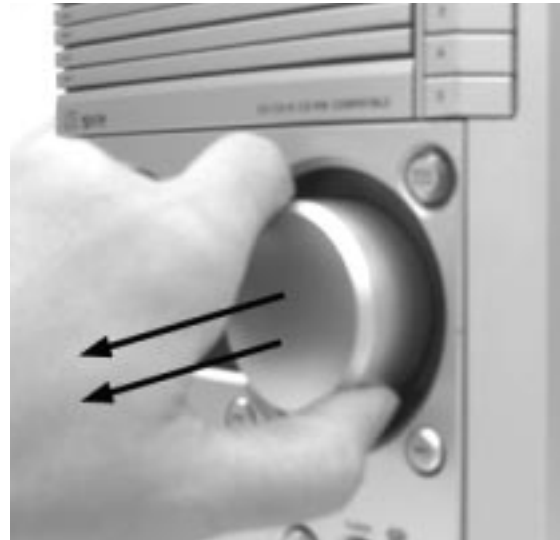
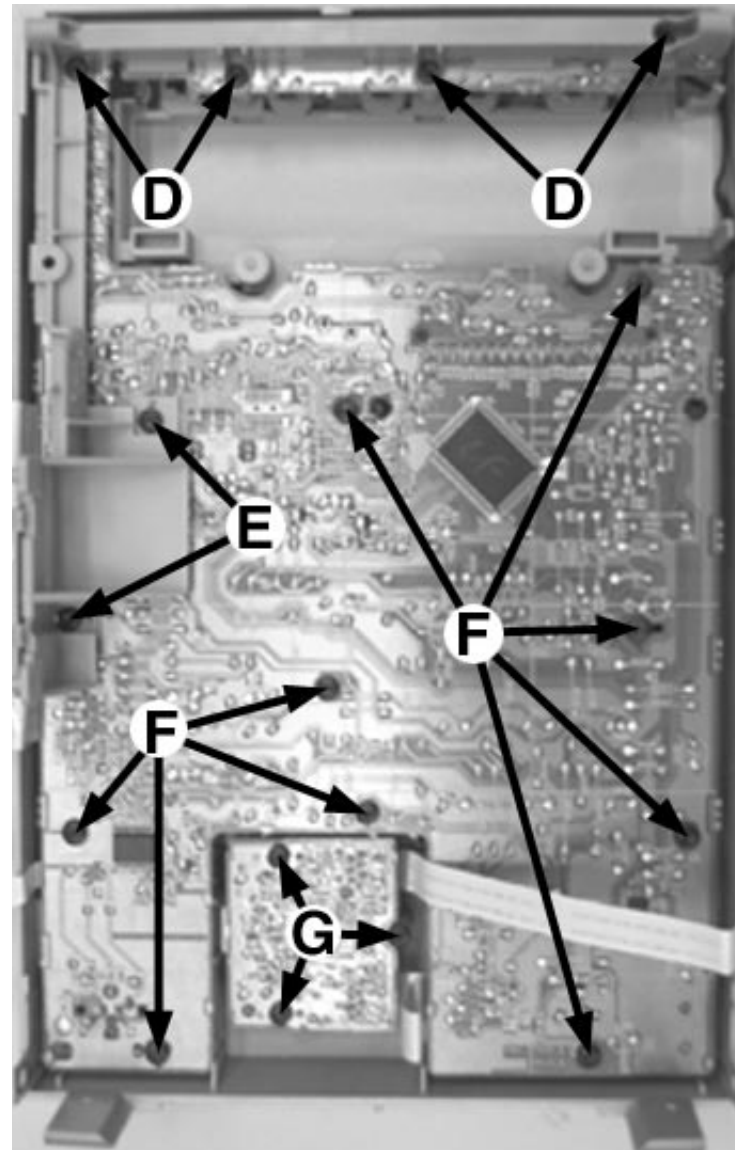

Figure 7

Figure 8



Dismantling of the Rear Panel assembly

- 1) Loosen 3 screws H and 2 catches C3 (see Figure 9) to remove the Tuner Board assembly.
- 2) Loosen 1 screw K (see Figure 9) to free the Mains Socket Board (pos 1102-1002B).
- 3) Loosen 4 screws J and 2 catches C4 (see Figure 9) to remove the Cabinet Rear (pos 256) by sliding it out towards the rear (see Figure 10).
Note : Tuner Board assembly and Mains Socket Board can also be removed together with the Cabinet Rear.
- 4) Loosen 4 screws L (see Figure 9) to remove the Fan (pos 1104) from the Cabinet Rear.

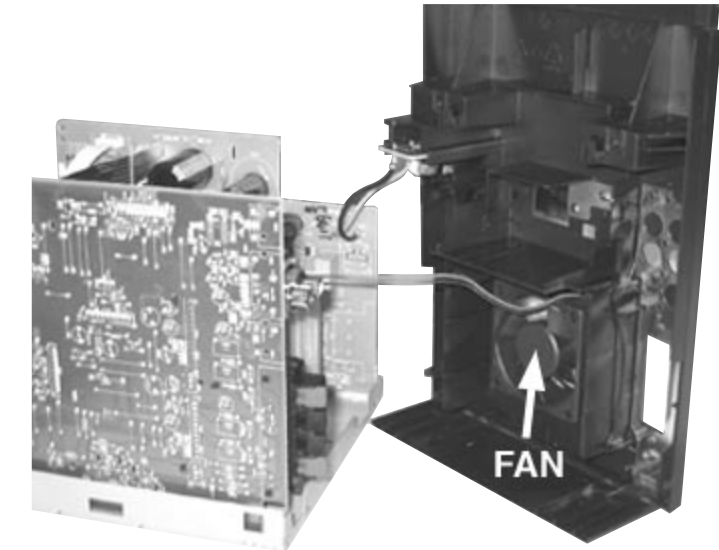
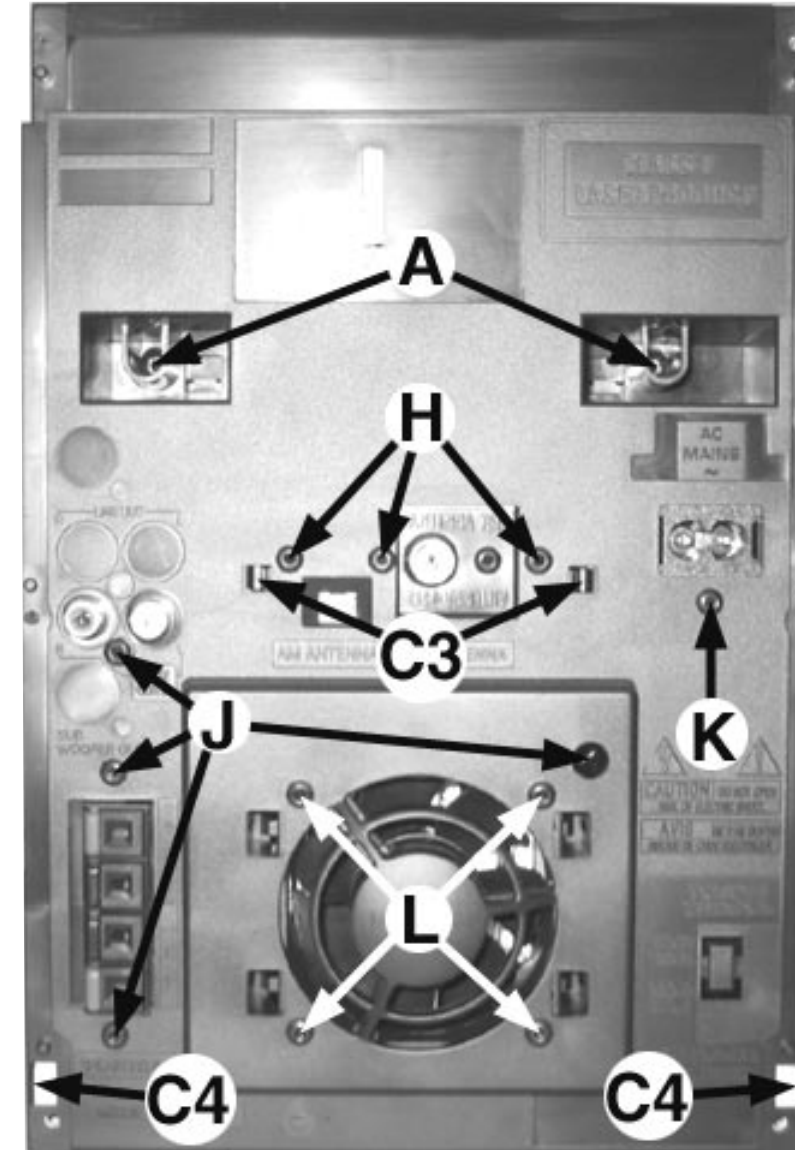

Figure 10

Figure 9



DISMANTLING INSTRUCTIONS

Repair Hints & Service Positions

- 1) During repair it is possible to disconnect the ECO6 Tuner board and/or 5DTC Module completely unless the fault is suspected to be in that area. This will not affect the performance of the rest of the set.

Note: The flex cables are very fragile, care should be taken not to damage them during repair. After repair, be very sure that the flex cables are inserted properly into the flex sockets before encasing, otherwise faults may occur.

Service position A

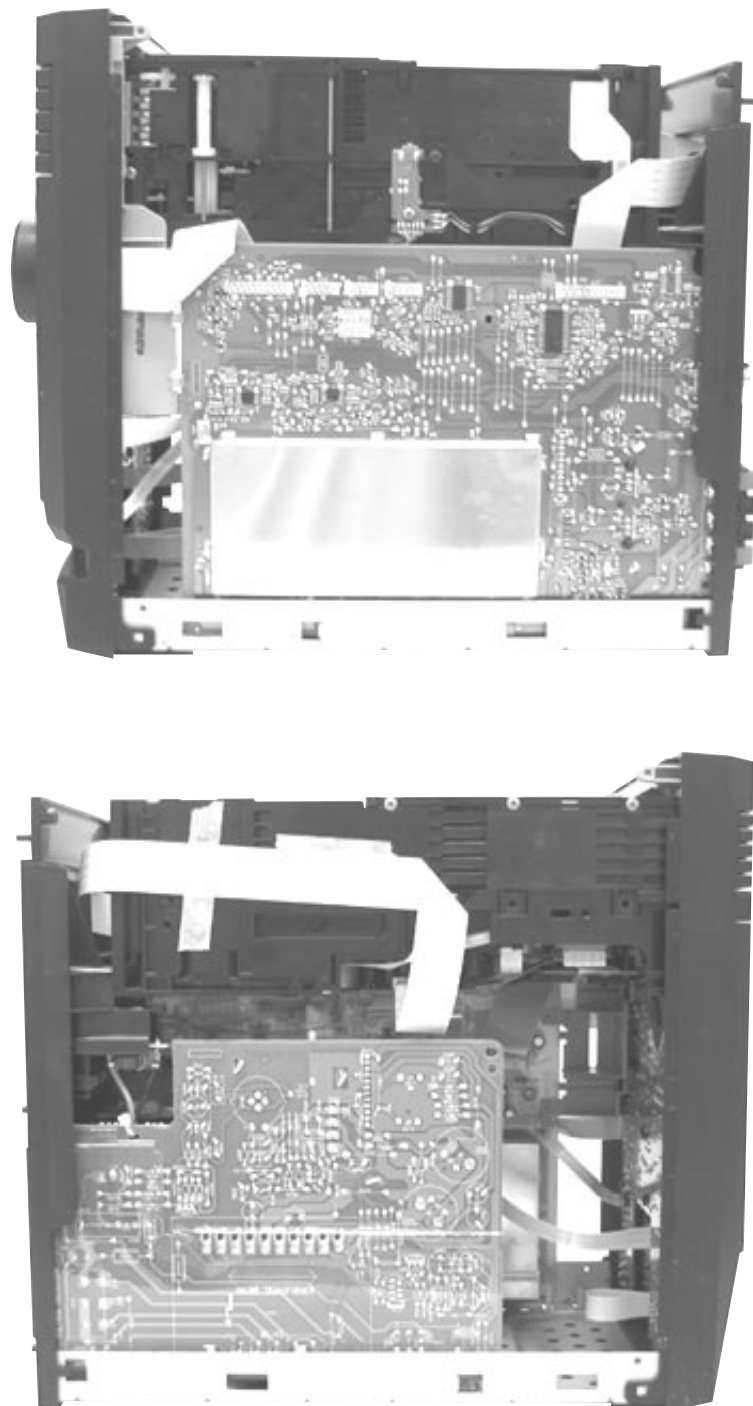

Service position B

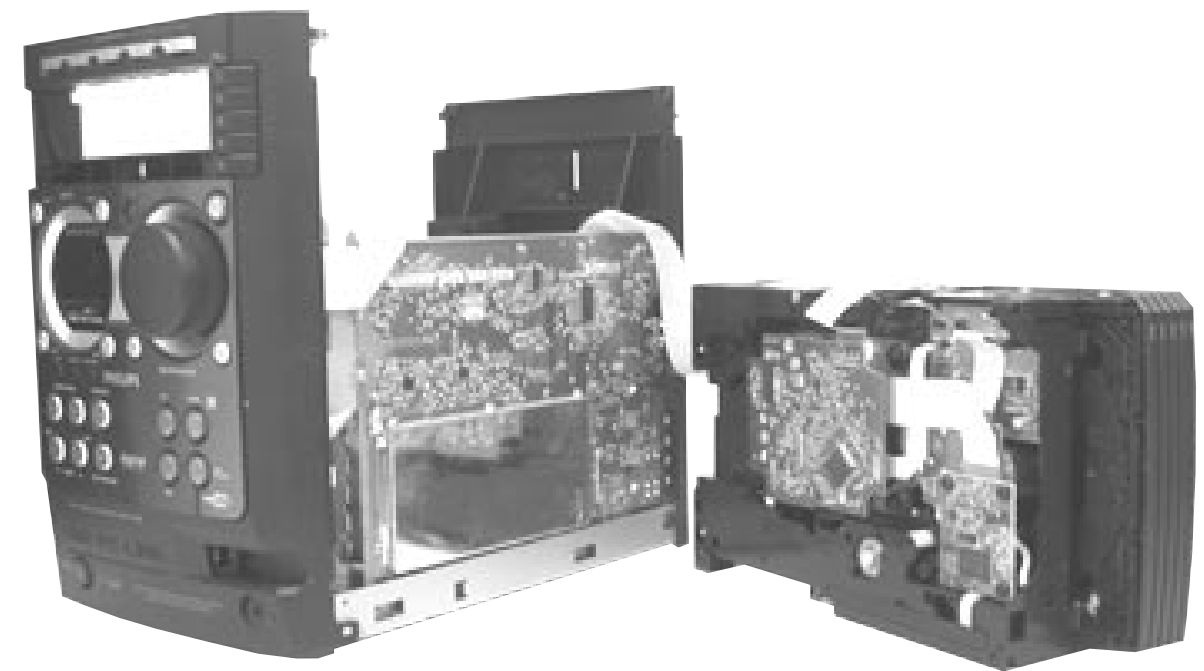

Service position C

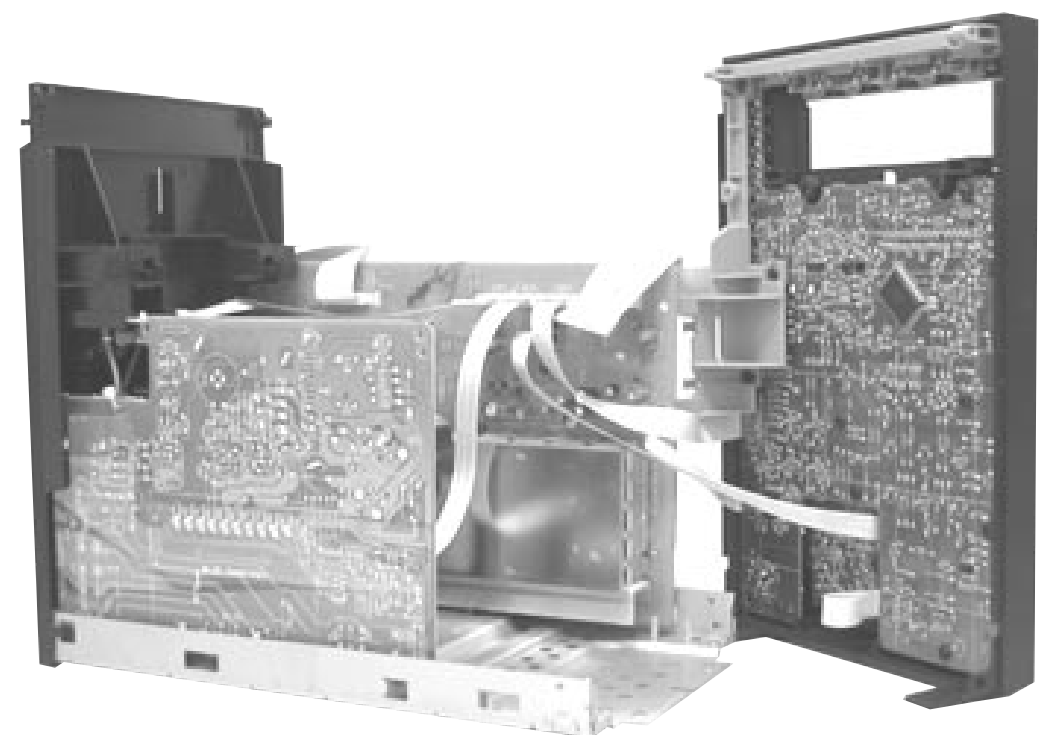

SERVICE TEST PROGRAM

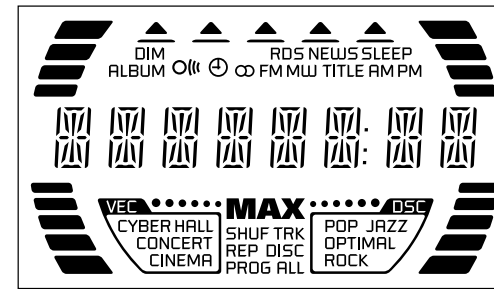
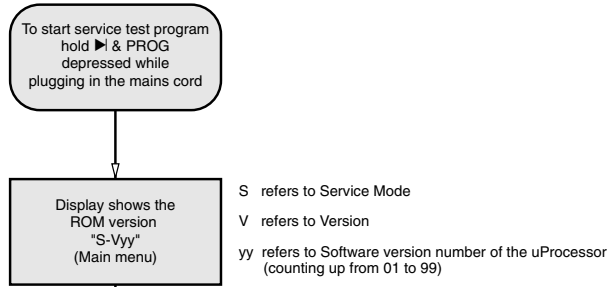

Figure 1

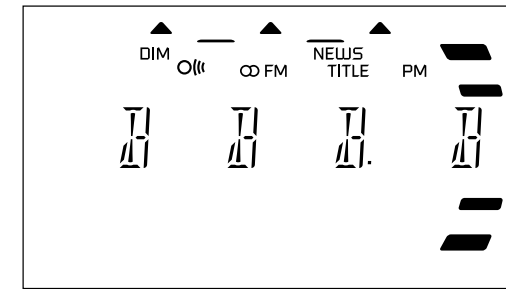
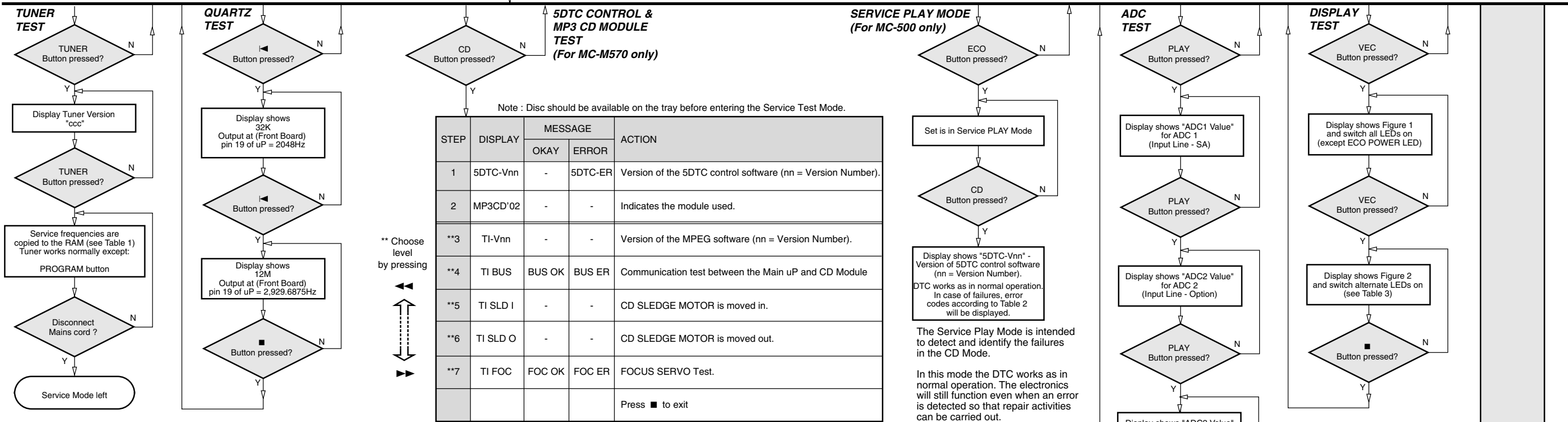

Figure 2



Note : Disc should be available on the tray before entering the Service Test Mode.

STEP	DISPLAY	MESSAGE		ACTION
		OKAY	ERROR	
1	5DTC-Vnn	-	5DTC-ER	Version of the 5DTC control software (nn = Version Number).
2	MP3CD'02	-	-	Indicates the module used.
**3	TI-Vnn	-	-	Version of the MPEG software (nn = Version Number).
**4	TI BUS	BUS OK	BUS ER	Communication test between the Main uP and CD Module
**5	TI SLD I	-	-	CD SLEDGE MOTOR is moved in.
**6	TI SLD O	-	-	CD SLEDGE MOTOR is moved out.
**7	TI FOC	FOC OK	FOC ER	FOCUS SERVO Test.
				Press ■ to exit

The Service Play Mode is intended to detect and identify the failures in the CD Mode. In this mode the DTC works as in normal operation. The electronics will still function even when an error is detected so that repair activities can be carried out.

PRESET	Europe "EUR"	East Europe "EAS"	East Eur. Extended-band "EAS"	USA "USA"	Oversea "OSE"
1	87.5MHz	87.5MHz	65.81MHz	87.5MHz	87.5MHz
2	108MHz	108MHz	108MHz	108MHz	108MHz
3	531kHz	531kHz	74MHz	530kHz	531/530kHz*
4	1602kHz	1602kHz	87.5MHz	1700kHz	1602/1700kHz*
5	558kHz	558kHz	531kHz	560kHz	558/560kHz*
6	1494kHz	1494kHz	1602kHz	1500kHz	1494/1500kHz*
7	87.5MHz	87.5MHz	558kHz	98MHz	87.5/98MHz*
8	87.5MHz	87.5MHz	1494kHz	87.5MHz	87.5MHz
9	87.5MHz	87.5MHz	98MHz	87.5MHz	87.5MHz
10	87.5MHz	87.5MHz	70.01MHz	87.5MHz	87.5MHz
11	98MHz	98MHz	65.81MHz	87.5MHz	98/87.5MHz*

Table 1

Note: * Depending on the selected grid frequency (9 or 10kHz). By holding the PROG and buttons depressed while switching on the Mains supply, one of the undermentioned features will be activated:
 - the tuning grid frequency is toggled between 9kHz and 10kHz for the Oversea (/21) version.
 - the extended FM1 (65.81MHz - 74MHz) is toggled on and off for East Eur. (/34) version.

Error code	Error Description
E1000	Focus Error Triggered when the focus cannot be found within a certain time when starting up the CD, or if the focus is lost for more than a certain time during playing of CD.
E1001	Radial Error Triggered when the radial servo is off-track for a certain time during playing of CD.
E1002	Sledge In Error The sledge did not reach its inner position (inner-switch is still close) before approximately 6 seconds have passed by. Inner-switch or sledge motor problem.
E1003	Sledge Out Error The sledge did not come out of its inner position (inner-switch is still open) before approximately 250ms have passed by. Inner-switch or sledge motor problem.
E1005	Jump Error Triggered in normal play when the jump destination could not be found within a certain time.
E1006	Subcode Error Triggered when a new subcode was missing for a certain time during playing of CD.
E1007	PLL Error The Phase Lock Loop could not lock within a certain time.
E1008	Turntable Motor Error Generated when the CD could not reached 75% of speed during start-up within a certain time. Disc motor problem.
E1020	Focus Search Error The focus point has not been found within a certain time.
E1061	The tray could not enter the inside position and is opening again. This can happen if the tray is blocked such that it cannot go fully inside, or if the 5DTC control module is defective and never closes.
E1079	The tray could not reach the outside position and is stopped at its blocked position. This can happen if the tray is blocked such that it cannot go fully outside, or if the 5DTC control module is defective and never opens.

Table 2

LEDs	MC-M570	MC-500
CD	OFF	-
TUNER	ON	-
AUX	OFF	-
USB PC LINK	ON	-
MAX SOUND	OFF	OFF
USB Indicator	ON	ON

Table 3

ADC Test is used for checking the ADC inputs to the microprocessor. The display shows an ADC value between 0 and 255 for an input signal between 0 and 5V.

TEST	Activated with	ACTION
EEPROM TEST		A test pattern will be sent to the EEPROM. "PASS" is displayed if the uProcessor read back the test pattern correctly, otherwise "FAIL" will be displayed.
EEPROM FORMAT TEST		Load default data. Display shows "NEW" for 1 second. Caution! All presets from the customer will be lost!!
DEMO TOGGLE	MAX SOUND	Pressing this button will toggle between DEMO ON and DEMO OFF. The DEMO status will scroll once across the Display.
ROTARY ENCODER TEST	Rotary Volume Knob	Display shows value for 2 seconds. Values increases or decreases until Volume Maximum (0dB) or Volume Minimum (VOL MUTE) is reached.
MICRONAS FIRMWARE VERSION	USB PC LINK 	To read out the Firmware Version of IC UAC3553 on the USB PC LINK Board. Display shows "Vxxxx" (xxxx = Firmware Version number).
LEAVE SERVICE TEST PROGRAM	Disconnect mains cord	

SET BLOCK DIAGRAM

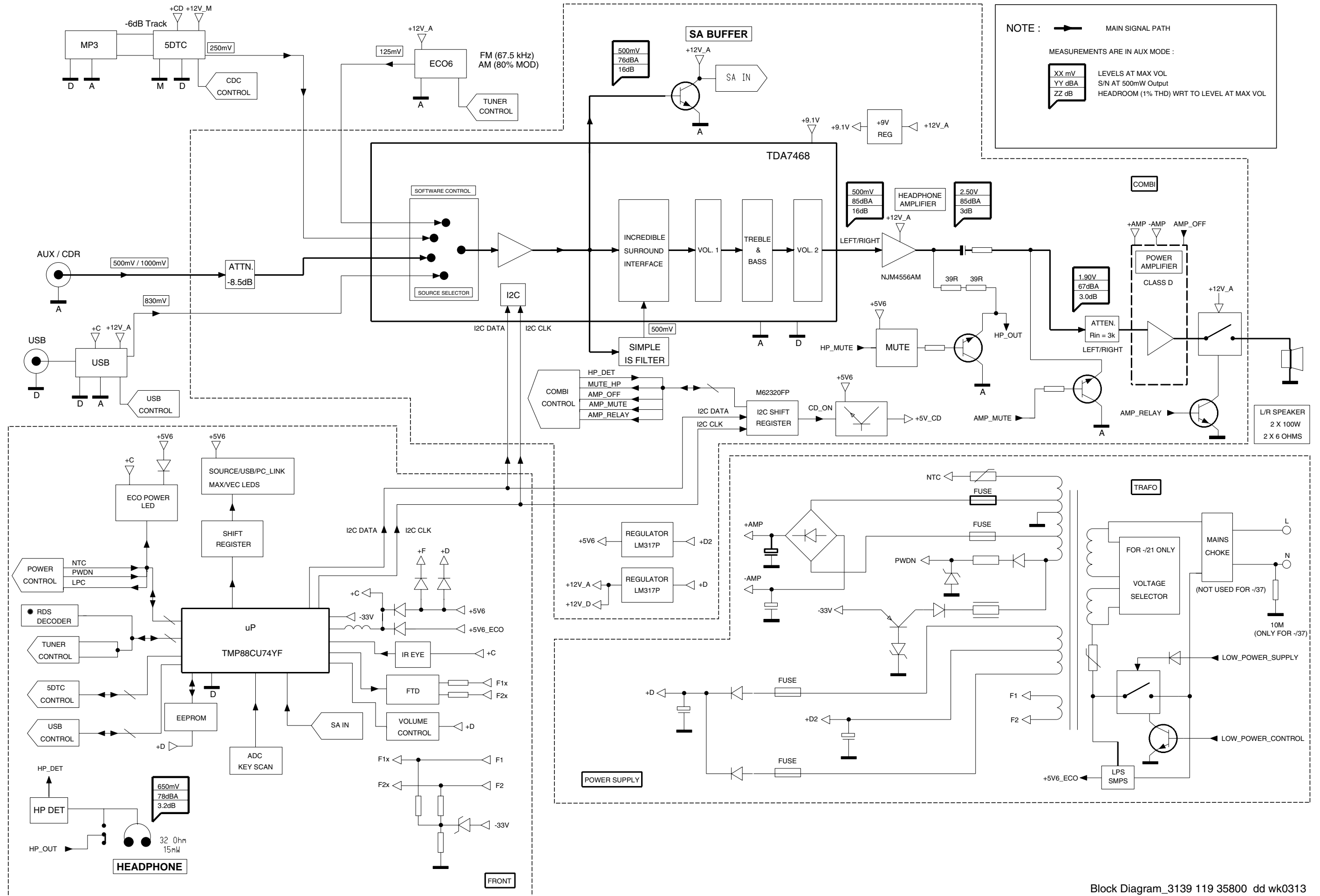

SET WIRING DIAGRAM

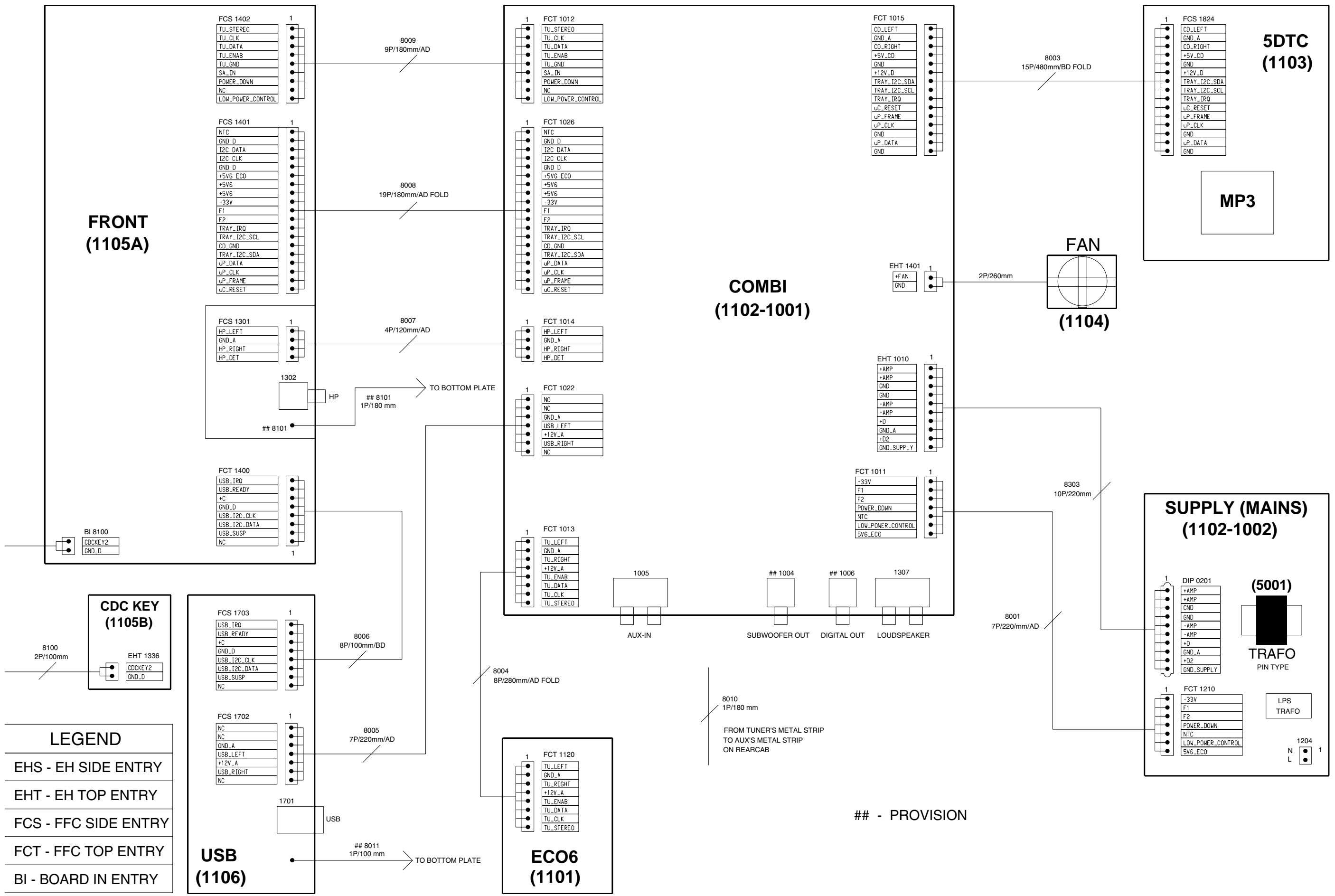

FRONT BOARD - CIRCUIT DIAGRAM (Part 1)

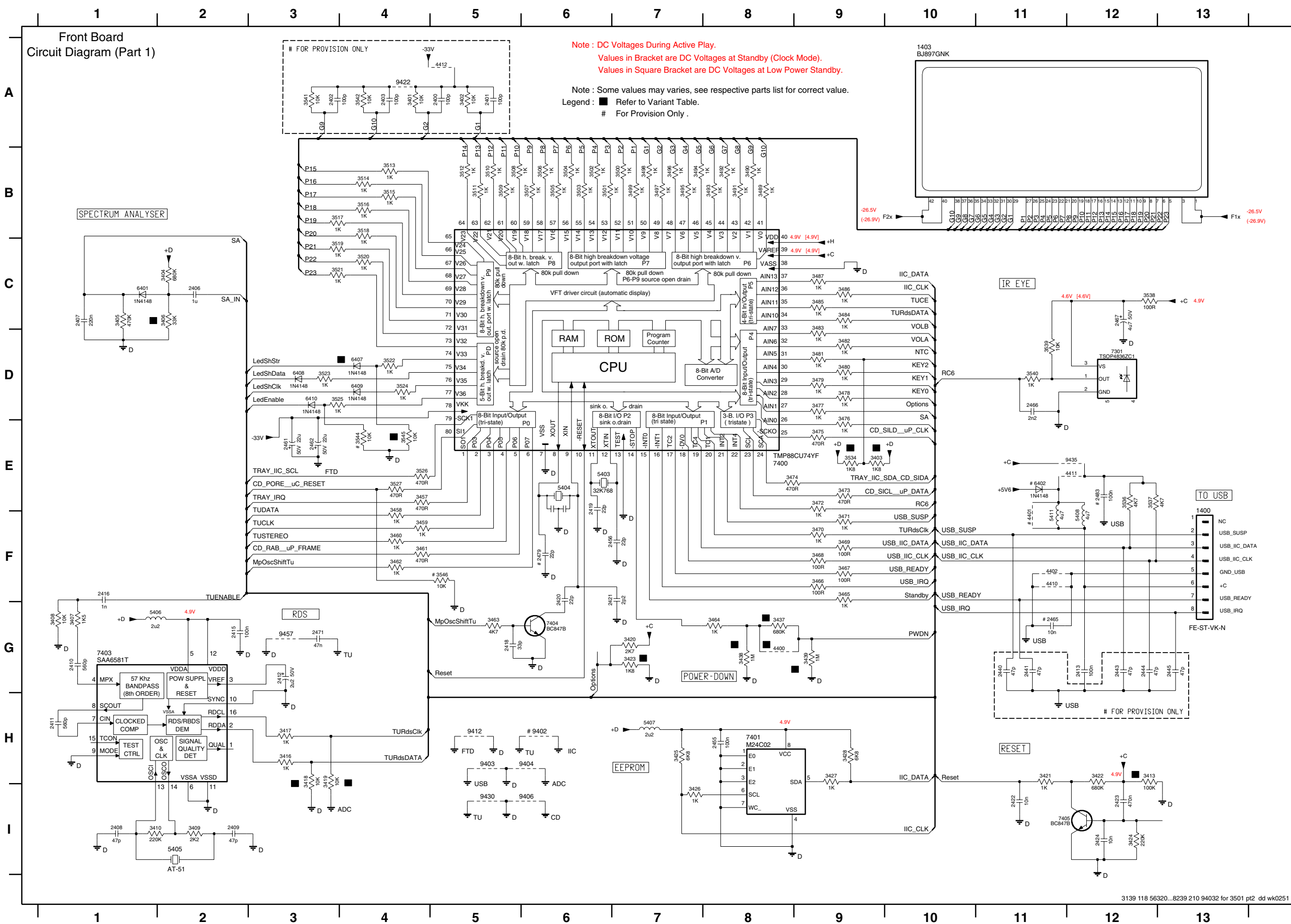

- 1400 F13 3508 B5
- 1403 A10 3509 B5
- 2400 A5 3510 B5
- 2401 A5 3511 B5
- 2402 A3 3512 B5
- 2403 A4 3513 B4
- 2406 C2 3514 B4
- 2407 C1 3515 B4
- 2408 I1 3516 B4
- 2409 C2 3517 B3
- 2410 G1 3518 B4
- 2411 H1 3519 C3
- 2412 G3 3520 C4
- 2413 G12 3521 C3
- 2415 G2 3522 D4
- 2416 F1 3523 D3
- 2418 G5 3524 D4
- 2419 E6 3525 D3
- 2420 F6 3526 E4
- 2421 F7 3527 E4
- 2422 H1 3528 E9
- 2423 H2 3529 E12
- 2424 H2 3530 E12
- 2440 G11 3538 C12
- 2441 G11 3539 D11
- 2443 G12 3540 D11
- 2444 G12 3541 A3
- 2445 G13 3542 A4
- 2455 H8 3544 E4
- 2456 F7 3545 E4
- 2461 E3 3546 F5
- 2462 E3 4400 G8
- 2465 G11 4401 F11
- 2466 D11 4402 F11
- 2467 C12 4410 F11
- 2471 G3 4411 E12
- 2479 F6 4412 A5
- 2483 E12 5403 E6
- 3401 A4 5404 E6
- 3402 A5 5405 I2
- 3403 E9 5406 G1
- 3404 C2 5407 H7
- 3405 C1 5408 F12
- 3406 C2 5411 F11
- 3407 G1 6401 C1
- 3408 G1 6402 E11
- 3409 I2 6407 D4
- 3410 H1 6408 D3
- 3413 H12 6409 D4
- 3416 H3 6410 D3
- 3417 H3 7301 D12
- 3418 H3 7400 E8
- 3419 H3 7401 H8
- 3420 G7 7403 G1
- 3421 H11 7404 G6
- 3422 H12 7405 H12
- 3423 G7 9402 H6
- 3424 H2 9403 H5
- 3425 H7 9404 H6
- 3426 I7 9406 I6
- 3427 H9 9412 H5
- 3428 H9 9422 A4
- 3437 G8 9430 I5
- 3438 G8 9435 E12
- 3439 G9 9457 G3
- 3457 E4 7403 G1
- 3458 F4 7404 G6
- 3459 F4 7405 H12
- 3460 F4 9402 H6
- 3461 F4 9403 H5
- 3462 F4 9404 H6
- 3463 G8 9406 I6
- 3464 G5 9412 H5
- 3465 F9 9422 A4
- 3466 F9 9430 I5
- 3467 F9 9435 E12
- 3468 F9 9457 G3
- 3469 F9 7403 G1
- 3470 F9 7404 G6
- 3471 F9 7405 H12
- 3472 E9 9402 H6
- 3473 E9 9403 H5
- 3474 E8 9404 H6
- 3475 E8 9406 I6
- 3476 D9 9412 H5
- 3477 D9 9422 A4
- 3478 D9 9430 I5
- 3479 D9 9435 E12
- 3480 D9 7403 G1
- 3481 D9 7404 G6
- 3482 D9 7405 H12
- 3483 D9 9402 H6
- 3484 C9 9403 H5
- 3485 C9 9404 H6
- 3486 C9 9406 I6
- 3487 C9 9412 H5
- 3488 B8 9422 A4
- 3489 B8 9430 I5
- 3490 B8 9435 E12
- 3491 B8 7403 G1
- 3492 B8 7404 G6
- 3493 B8 7405 H12
- 3494 B7 9402 H6
- 3495 B7 9403 H5
- 3496 B7 9404 H6
- 3497 B7 9406 I6
- 3498 B7 9412 H5
- 3499 B7 9422 A4
- 3500 B7 9430 I5
- 3501 B6 9435 E12
- 3502 B6 7403 G1
- 3503 B6 7404 G6
- 3504 B6 7405 H12
- 3505 B6 9402 H6
- 3506 B6 9403 H5
- 3507 B6 9404 H6

FRONT BOARD - CIRCUIT DIAGRAM (Part 2)

1301 A7	1306 D7	1311 F8	1316 F9	1321 F7	1326 D8	2303 B6	2308 F5	2459 B4	3300 A1	3307 E2	3312 E3	3317 A6	3322 C7	3328 C8	3334 F9	3339 F7	3344 F8	3529 C2	4406 D1	5401 B3	6303 F1	7406 A2	8101 B7
1302 A9	1307 D6	1312 E6	1317 E9	1322 F7	1327 D8	2304 B8	2309 D5	2460 B4	3301 B1	3308 E2	3313 E3	3318 C5	3323 D5	3329 D7	3335 E5	3340 F7	3345 C6	3530 C2	4407 D1	5410 A3	6304 F2	7407 B3	9405 B3
1303 A5	1308 D6	1313 F6	1318 E8	1323 F8	1328 F9	2305 B8	2310 D8	2469 F4	3304 E1	3309 E2	3314 E4	3319 C6	3324 D6	3330 D8	3336 F6	3341 F7	3346 E3	3531 C3	5300 A8	6300 A1	6305 F3	7408 F3	
1304 D7	1309 F6	1314 E7	1319 E9	1324 F7	1330 E6	2306 B8	2457 D2	2470 F3	3305 E1	3310 E2	3315 E4	3320 C7	3325 D6	3331 D8	3337 F6	3342 F8	3347 E4	4403 F3	5301 B8	6301 B2	6306 E3	7409 F4	
1305 D7	1310 F6	1315 F8	1320 E8	1325 E7	2302 B6	2307 E5	2458 D2	2473 C1	3306 E1	3311 E3	3316 A6	3321 C7	3326 D7	3332 D9	3338 F6	3343 F8	3528 C1	4404 F4	5302 B8	6302 F1	6307 E4	8100 C9	

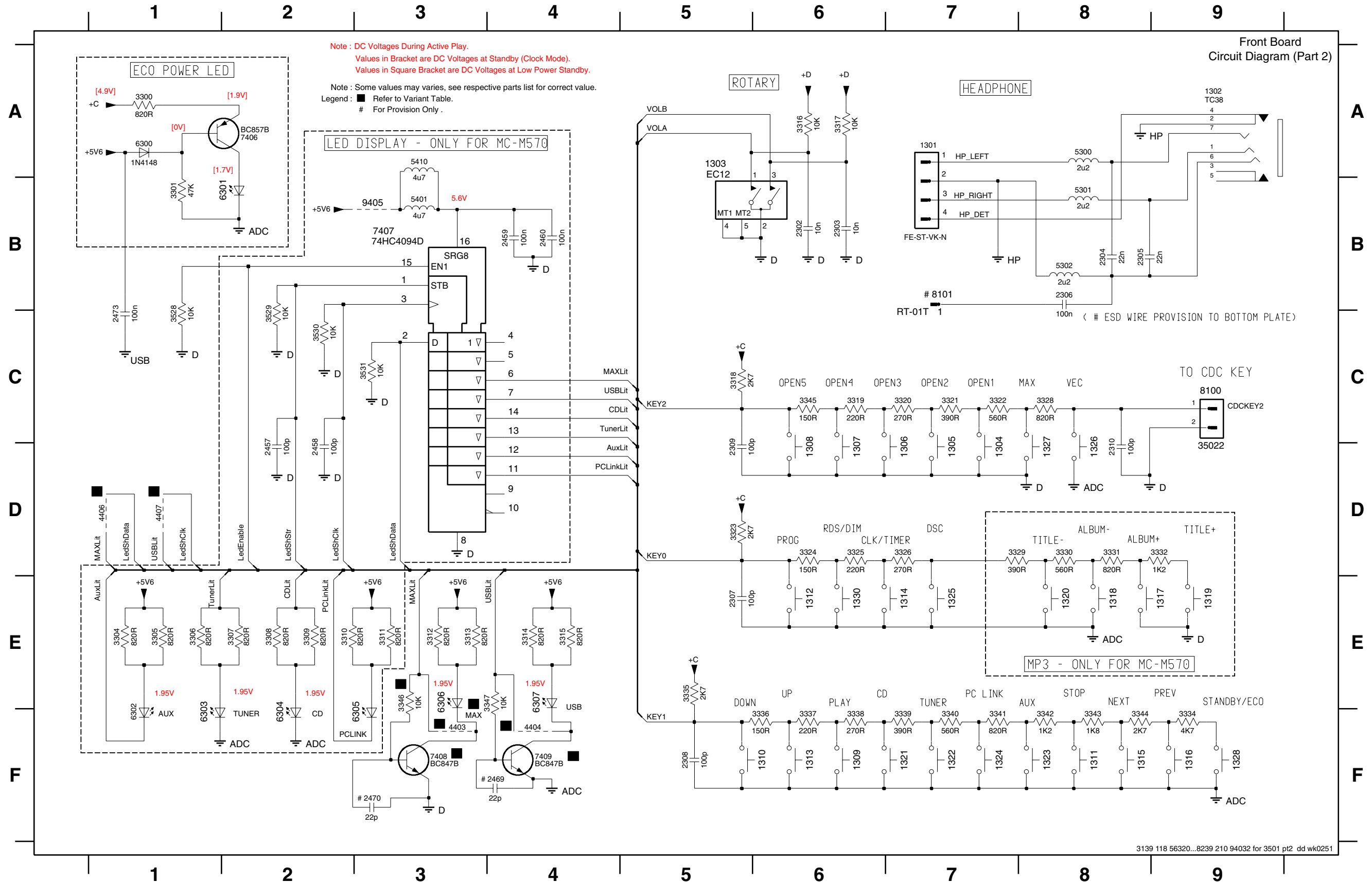

FRONT BOARD - CIRCUIT DIAGRAM (Part 3)

Front Board
Circuit Diagram (Part 3)

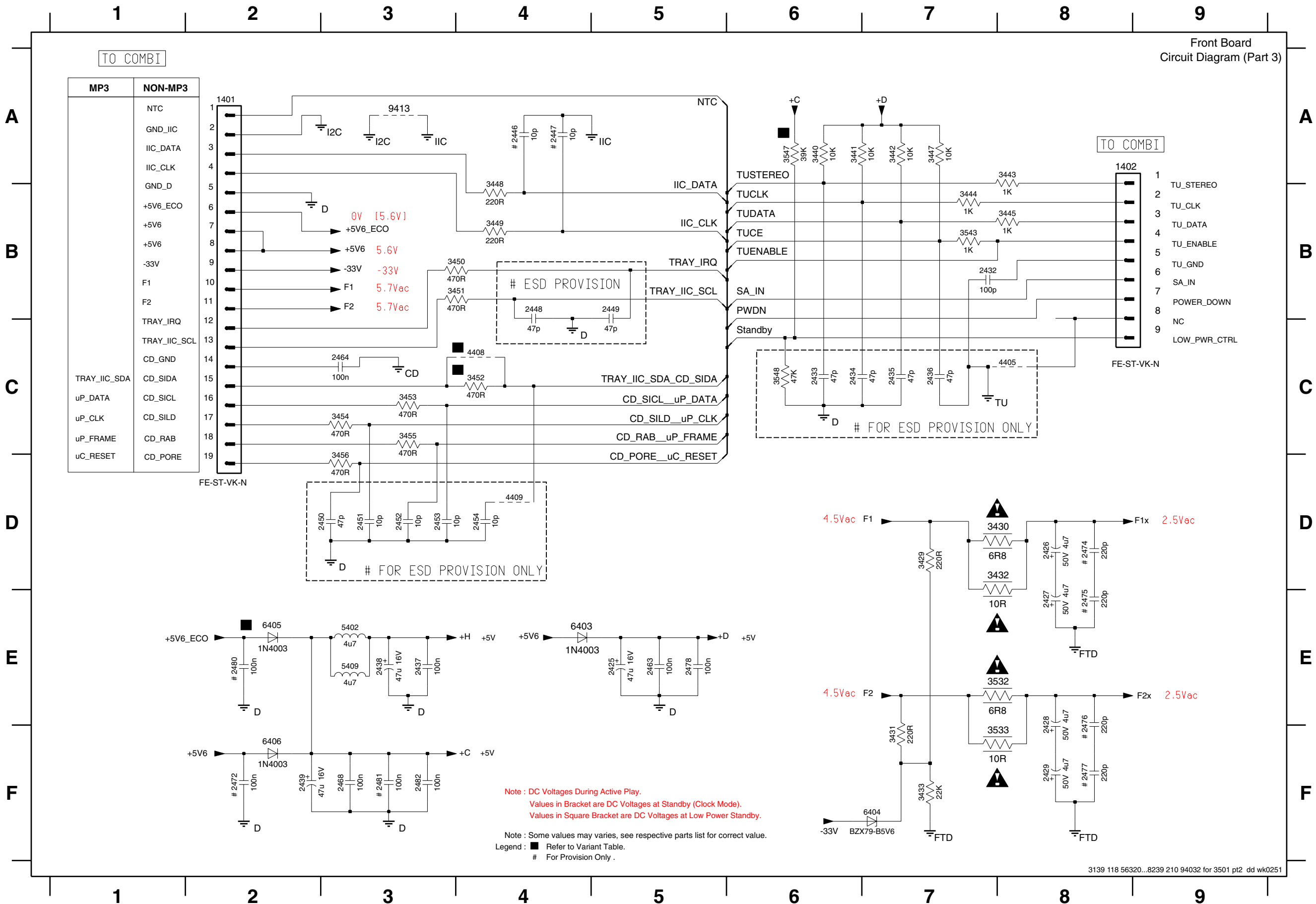

MP3	NON-MP3
	NTC
	GND_IIC
	IIC_DATA
	IIC_CLK
	GND_D
	+5V6_ECO
	+5V6
	+5V6
	-33V
F1	F1
F2	F2
TRAY_IRQ	
TRAY_IIC_SCL	
CD_GND	CD_SIDA
TRAY_IIC_SDA	CD_SICL
uP_DATA	CD_SILD
uP_CLK	CD_RAB
uP_FRAME	CD_PORE
uC_RESET	

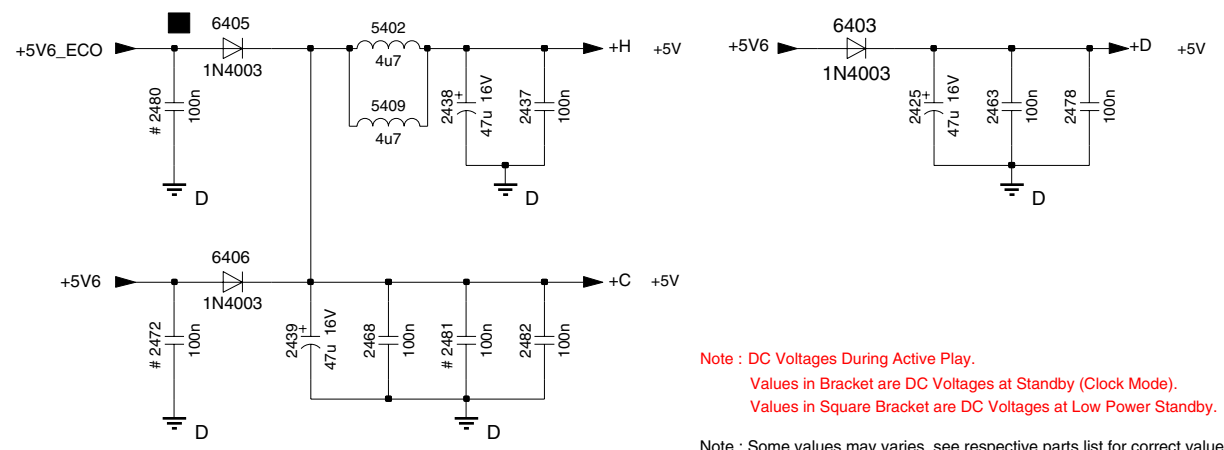
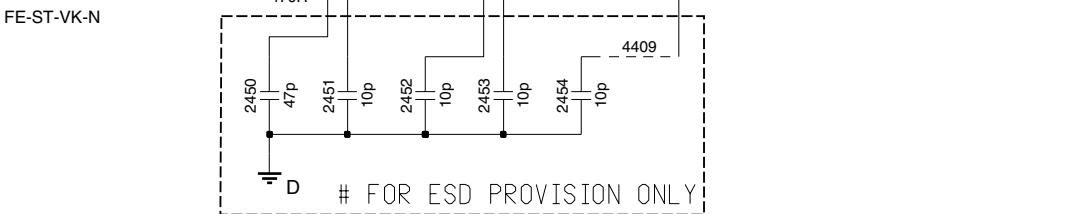
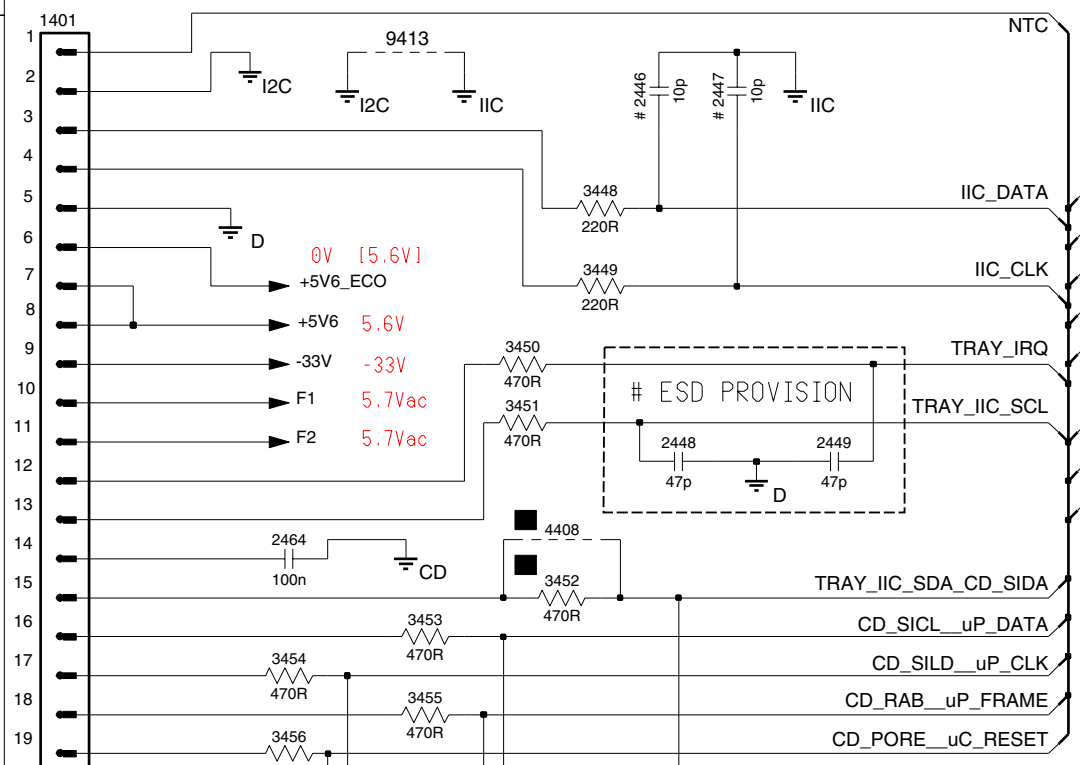

Note : DC Voltages During Active Play.
 Values in Bracket are DC Voltages at Standby (Clock Mode).
 Values in Square Bracket are DC Voltages at Low Power Standby.
 Note : Some values may varies, see respective parts list for correct value.
 Legend : ■ Refer to Variant Table.
 # For Provision Only .

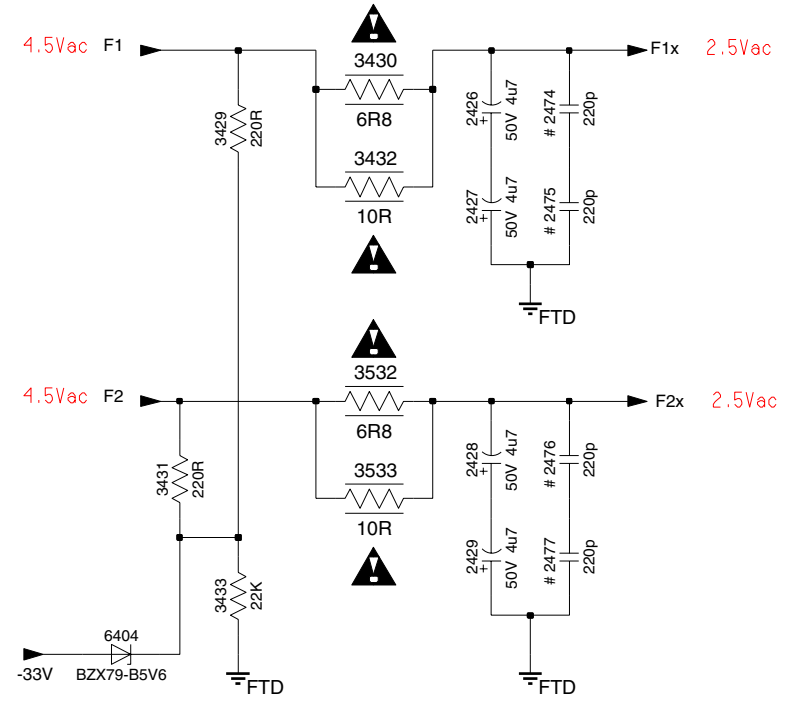
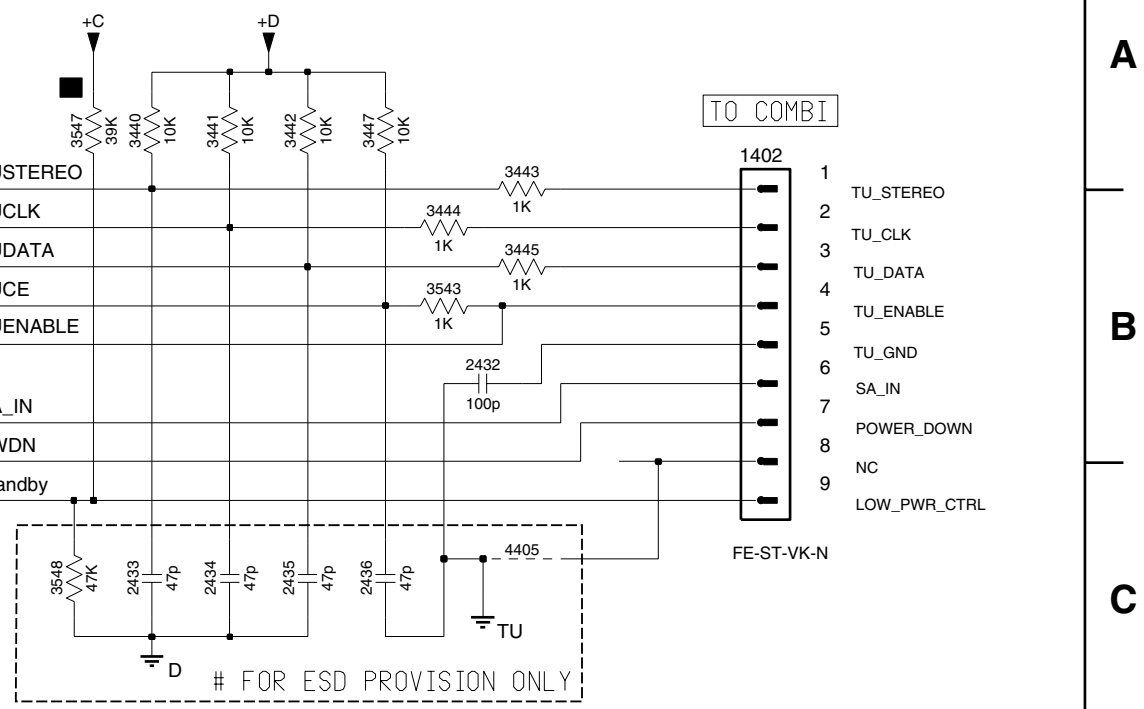

- 1401 A2
- 1402 A8
- 2425 E5
- 2426 D8
- 2427 E8
- 2428 E8
- 2429 F8
- 2432 B7
- 2433 C6
- 2434 C6
- 2435 C7
- 2436 C7
- 2437 E3
- 2438 E3
- 2439 F2
- 2446 A4
- 2447 A4
- 2448 B4
- 2449 B5
- 2450 D3
- 2451 D3
- 2452 D3
- 2453 D3
- 2454 D4
- 2463 E5
- 2464 C3
- 2468 F3
- 2472 F2
- 2474 D8
- 2475 E8
- 2476 E8
- 2477 F8
- 2478 E5
- 2480 E2
- 2481 F3
- 2482 F3
- 3429 D7
- 3430 D8
- 3431 F7
- 3432 D8
- 3433 F7
- 3440 A6
- 3441 A6
- 3442 A7
- 3443 A8
- 3444 B7
- 3445 B8
- 3447 A7
- 3448 B4
- 3449 B4
- 3450 B4
- 3451 B4
- 3452 C4
- 3453 C3
- 3454 C3
- 3455 C3
- 3532 E8
- 3533 F8
- 3543 B7
- 3547 A6
- 3548 C6
- 4405 C8
- 4408 C4
- 4409 D4
- 5402 E3
- 5409 E3
- 6403 E4
- 6404 F7
- 6405 E2
- 6406 F2
- 9413 A3

CDC KEY BOARD - COMPONENT LAYOUT

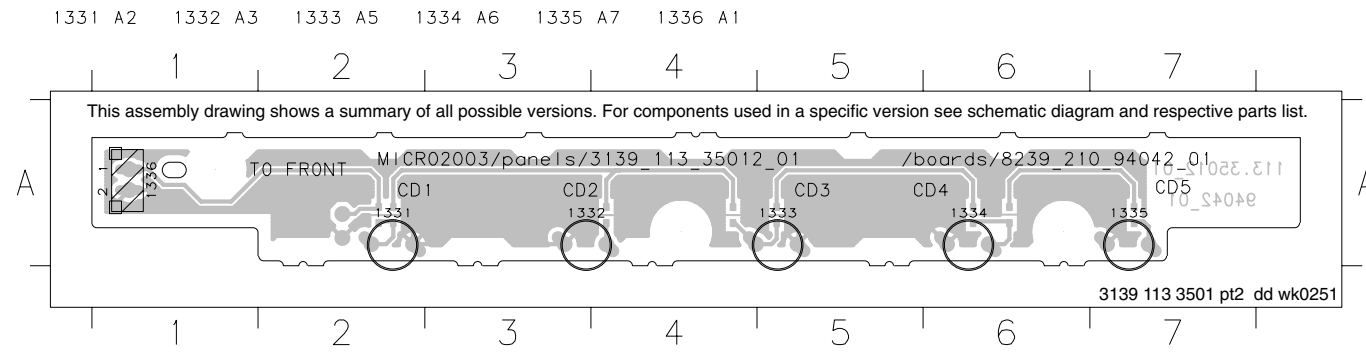

CDC KEY BOARD - CHIP LAYOUT

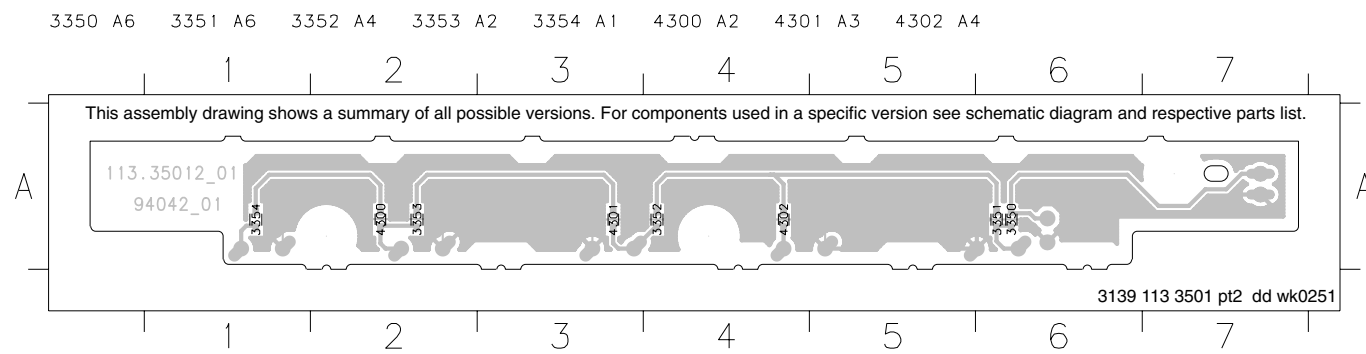

CDC KEY BOARD - CIRCUIT DIAGRAM

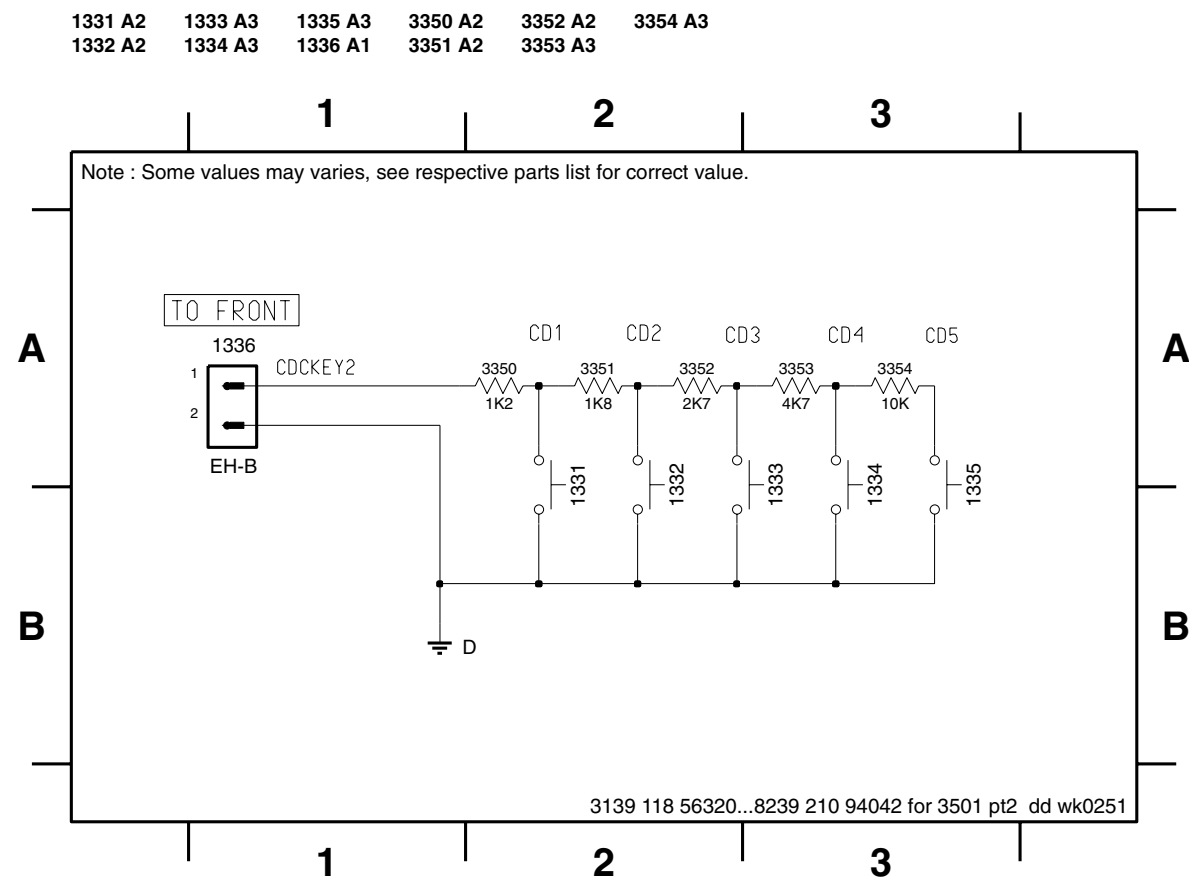

VARIANT TABLE

Model / Version	MC-500/22 MC-500/25	MC-500/30 MC-500/33 MC-500/37	MCM530/22	MCM530/M590/21 MCM530/30 MCM530/37
Item No.				
3346	10K	10K	—	—
3347	10K	10K	—	—
3413	100K	—	100K	100K
3403 / 3534	1K8	1K8	—	—
3406	33K	33K	15K	15K
3418	—	10K	—	10K
3419	—	10K	—	10K
3423	1K8	—	1K8	1K8
3437	680K	680K	—	—
3438	1M	1M	2M2	2M2
3439	1M	1M	—	—
3452	—	—	470R	470R
3545	10K	10K	—	—
3547	39K	—	—	—
4400	—	—	X	X
4403	—	—	X	X
4404	—	—	X	X
4406	X	X	—	—
4407	X	X	—	—
4408	X	X	—	—
6405	X	—	X	X
6407	—	—	X	X
7408	X	X	—	—
7409	X	X	—	—

X - Item in use.

ELECTRICAL PARTS LIST - FRONT BOARD**MISCELLANEOUS**

1301	4822 265 11183	Flex Connector 4P	2409	4822 126 11785	47pF 5% 50V	/22
1302	2422 026 05059	Headphone Socket	2410	4822 126 14249	560pF 10% 50V	/22
1303	2422 129 16708	Rotary Encoder 24P	2411	4822 126 14249	560pF 10% 50V	/22
1304	4822 276 13775	Tact Switch	2412	4822 124 22652	2,2uF 20% 50V	/22
1305	4822 276 13775	Tact Switch	2413	2238 586 59812	100nF 50V	
1306	4822 276 13775	Tact Switch	2415	2238 586 59812	100nF 50V	/22
1307	4822 276 13775	Tact Switch	2416	5322 126 11578	1nF 10% 50V	/22
1308	4822 276 13775	Tact Switch	2418	2222 867 15339	33pF 5% 50V	
1309	4822 276 13775	Tact Switch	2419	4822 122 33761	22pF 5% 50V	
1310	4822 276 13775	Tact Switch	2420	4822 122 33761	22pF 5% 50V	
1311	4822 276 13775	Tact Switch	2421	4822 126 14223	2,2pF 50V	
1312	4822 276 13775	Tact Switch	2422	5322 126 11583	10nF 10% 50V	
1313	4822 276 13775	Tact Switch	2423	3198 017 44740	470nF 10V	
1314	4822 276 13775	Tact Switch	2424	5322 126 11583	10nF 10% 50V	
1315	4822 276 13775	Tact Switch	2425	4822 124 81286	47uF 20% 16V	
1316	4822 276 13775	Tact Switch	2426	4822 124 12032	4,7uF 20% 50V	
1317	4822 276 13775	Tact Switch	2427	4822 124 12032	4,7uF 20% 50V	
1318	4822 276 13775	Tact Switch	2428	4822 124 12032	4,7uF 20% 50V	
1319	4822 276 13775	Tact Switch	2429	4822 124 12032	4,7uF 20% 50V	
1320	4822 276 13775	Tact Switch	2432	2020 552 94427	100pF 5% 50V	
1321	4822 276 13775	Tact Switch	2437	2238 586 59812	100nF 50V	
1322	4822 276 13775	Tact Switch	2438	4822 124 81286	47uF 20% 16V	
1323	4822 276 13775	Tact Switch	2439	4822 124 81286	47uF 20% 16V	
1324	4822 276 13775	Tact Switch	2455	2238 586 59812	100nF 50V	
1325	4822 276 13775	Tact Switch	2456	4822 122 33761	22pF 5% 50V	
1326	4822 276 13775	Tact Switch	2457	2020 552 94427	100pF 5% 50V	
1327	4822 276 13775	Tact Switch	2458	2020 552 94427	100pF 5% 50V	
1328	4822 276 13775	Tact Switch	2459	2238 586 59812	100nF 50V	
1330	4822 276 13775	Tact Switch	2460	2238 586 59812	100nF 50V	
1331	4822 276 13775	Tact Switch	2461	3198 028 52290	22uF 20% 50V	
1332	4822 276 13775	Tact Switch	2462	3198 028 52290	22uF 20% 50V	
1333	4822 276 13775	Tact Switch	2463	2238 586 59812	100nF 50V	
1334	4822 276 13775	Tact Switch	2464	2238 586 59812	100nF 50V	
1335	4822 276 13775	Tact Switch	2466	4822 126 14238	2,2nF 50V	
1400	4822 265 11535	Flex Connector 8P	2467	4822 124 12032	4,7uF 20% 50V	
1401	4822 265 11545	Flex Connector 19P	2468	2238 586 59812	100nF 50V	
1402	4822 265 11531	Flex Connector 9P	2471	3198 017 34730	47nF 16V	/22
1403	3139 110 53291	FTD (BJ897GNK)	2473	2238 586 59812	100nF 50V	
			2478	2238 586 59812	100nF 50V	
			2482	2238 586 59812	100nF 50V	

CAPACITORS

2302	5322 126 11583	10nF 10% 50V
2303	5322 126 11583	10nF 10% 50V
2304	4822 126 14494	22nF 10% 25V
2305	4822 126 14494	22nF 10% 25V
2306	2238 586 59812	100nF 50V
2307	2020 552 94427	100pF 5% 50V
2308	2020 552 94427	100pF 5% 50V
2309	2020 552 94427	100pF 5% 50V
2310	2020 552 94427	100pF 5% 50V
2406	3198 017 41050	1uF 10V
2407	4822 126 13879	220nF +80/-20% 16V
2408	4822 126 11785	47pF 5% 50V /22

RESISTORS

3300	4822 116 52231	820R 5% 0,5W
3301	4822 117 12925	47k 1% 0,063W
3304	4822 117 12968	820R 5% 0,62W
3305	4822 117 12968	820R 5% 0,62W
3306	4822 117 12968	820R 5% 0,62W
3307	4822 117 12968	820R 5% 0,62W
3308	4822 117 12968	820R 5% 0,62W
3309	4822 117 12968	820R 5% 0,62W
3310	4822 117 12968	820R 5% 0,62W
3311	4822 117 12968	820R 5% 0,62W

ELECTRICAL PARTS LIST - FRONT BOARD

3312	4822 117 12968	820R 5% 0,62W	3423	4822 116 52249	1k8 5% 0,5W
3313	4822 117 12968	820R 5% 0,62W	3424	4822 117 12891	220k 1%
3314	4822 117 12968	820R 5% 0,62W	3425	4822 051 30682	6k8 5% 0,062W
3315	4822 117 12968	820R 5% 0,62W	3426	4822 051 30102	1k 5% 0,062W
3316	4822 051 30103	10k 5% 0,062W	3427	4822 051 30102	1k 5% 0,062W
3317	4822 051 30103	10k 5% 0,062W	3428	4822 051 30682	6k8 5% 0,062W
3318	4822 051 30272	2k7 5% 0,062W	3429	4822 116 83872	220R 5% 0,5W
3319	4822 051 30221	220R 5% 0,062W	3430	4822 052 10688 Δ	6R8 5% 0,33W
3320	4822 051 30271	270R 5% 0,062W	3431	4822 116 83872	220R 5% 0,5W
3321	4822 051 30391	390R 5% 0,062W	3432	4822 052 10109 Δ	10R 5% 0,33W
3322	4822 051 30561	560R 5% 0,062W	3433	4822 116 52257	22k 5% 0,5W
3323	4822 051 30272	2k7 5% 0,062W	3438	3198 021 32250	2M2 5%
3324	4822 051 30151	150R 5% 0,062W	3440	4822 051 30103	10k 5% 0,062W
3325	4822 051 30221	220R 5% 0,062W	3441	4822 051 30103	10k 5% 0,062W
3326	4822 116 83876	270R 5% 0,5W	3442	4822 051 30103	10k 5% 0,062W
3328	4822 117 12968	820R 5% 0,62W	3443	4822 051 30102	1k 5% 0,062W
3329	4822 051 30391	390R 5% 0,062W	3444	4822 051 30102	1k 5% 0,062W
3330	4822 116 52226	560R 5% 0,5W	3445	4822 051 30102	1k 5% 0,062W
3331	4822 116 52231	820R 5% 0,5W	3447	4822 051 30103	10k 5% 0,062W
3332	4822 116 52207	1k2 5% 0,5W	3448	4822 116 83872	220R 5% 0,5W
3334	4822 116 52283	4k7 5% 0,5W	3449	4822 116 83872	220R 5% 0,5W
3335	4822 051 30272	2k7 5% 0,062W	3450	4822 051 30471	470R 5% 0,062W
3336	4822 051 30151	150R 5% 0,062W	3451	4822 051 30471	470R 5% 0,062W
3337	4822 051 30221	220R 5% 0,062W	3452	4822 051 30471	470R 5% 0,062W
3338	4822 116 83876	270R 5% 0,5W	3453	4822 116 83883	470R 5% 0,5W
3339	4822 051 30391	390R 5% 0,062W	3454	4822 116 83883	470R 5% 0,5W
3340	4822 051 30561	560R 5% 0,062W	3455	4822 051 30471	470R 5% 0,062W
3341	4822 117 12968	820R 5% 0,62W	3456	4822 051 30471	470R 5% 0,062W
3342	4822 117 11817	1k2 1% 1/16W	3457	4822 051 30471	470R 5% 0,062W
3343	4822 117 12903	1k8 1% 0,063W	3458	4822 051 30102	1k 5% 0,062W
3344	4822 051 30272	2k7 5% 0,062W	3459	4822 051 30102	1k 5% 0,062W
3345	4822 051 30151	150R 5% 0,062W	3460	4822 051 30102	1k 5% 0,062W
3350	4822 117 11817	1k2 1% 1/16W	3461	4822 051 30471	470R 5% 0,062W
3351	4822 117 12903	1k8 1% 0,063W	3462	4822 051 30102	1k 5% 0,062W
3352	4822 051 30272	2k7 5% 0,062W	3463	4822 051 30472	4k7 5% 0,062W
3353	4822 051 30472	4k7 5% 0,062W	3464	4822 051 30102	1k 5% 0,062W
3354	4822 051 30103	10k 5% 0,062W	3465	4822 051 30102	1k 5% 0,062W
3404	4822 051 30684	680k 5% 0,062W	3466	4822 116 52175	100R 5% 0,5W
3405	4822 051 30474	470k 5% 0,062W	3467	4822 116 52175	100R 5% 0,5W
3406	4822 051 30153	15k 5% 0,062W	3468	4822 116 52175	100R 5% 0,5W
3407	4822 051 30152	1k5 5% 0,062W /22	3469	4822 116 52175	100R 5% 0,5W
3408	4822 051 30103	10k 5% 0,062W /22	3470	4822 050 11002	1k 1% 0,4W
3409	4822 051 30222	2k2 5% 0,062W /22	3471	4822 050 11002	1k 1% 0,4W
3410	4822 117 12891	220k 1% /22	3472	4822 051 30102	1k 5% 0,062W
3413	4822 117 13632	100k 1% 0,62W	3473	4822 051 30471	470R 5% 0,062W
3416	4822 051 30102	1k 5% 0,062W /22	3474	4822 051 30471	470R 5% 0,062W
3417	4822 051 30102	1k 5% 0,062W /22	3475	4822 051 30471	470R 5% 0,062W
3418	4822 050 21003	10k 1% 0,6W /21/21M/37	3476	4822 051 30102	1k 5% 0,062W
3419	4822 051 30103	10k 5% 0,062W /21/21M/37	3477	4822 051 30102	1k 5% 0,062W
3420	4822 051 30272	2k7 5% 0,062W	3478	4822 051 30102	1k 5% 0,062W
3421	4822 051 30102	1k 5% 0,062W	3479	4822 051 30102	1k 5% 0,062W
3422	4822 051 30684	680k 5% 0,062W	3480	4822 051 30102	1k 5% 0,062W

ELECTRICAL PARTS LIST - FRONT BOARD**RESISTORS**

3481	4822 051 30102	1k 5% 0,062W	3533	4822 052 10109 Δ	10R 5% 0,33W
3482	4822 050 11002	1k 1% 0,4W	3536	4822 051 30472	4k7 5% 0,062W
3483	4822 050 11002	1k 1% 0,4W	3537	4822 051 30472	4k7 5% 0,062W
3484	4822 051 30102	1k 5% 0,062W	3538	4822 116 52175	100R 5% 0,5W
3485	4822 051 30102	1k 5% 0,062W	3539	4822 051 30103	10k 5% 0,062W
3486	4822 051 30102	1k 5% 0,062W	3540	4822 051 30102	1k 5% 0,062W
3487	4822 051 30102	1k 5% 0,062W	3543	4822 051 30102	1k 5% 0,062W
3489	4822 051 30102	1k 5% 0,062W	4300	4822 051 30008	0R Jumper 0603
3490	4822 051 30102	1k 5% 0,062W	4301	4822 051 30008	0R Jumper 0603
3491	4822 051 30102	1k 5% 0,062W	4302	4822 051 30008	0R Jumper 0603
3492	4822 051 30102	1k 5% 0,062W	4400	4822 051 30008	0R Jumper 0603
3493	4822 051 30102	1k 5% 0,062W	4402	4822 051 30008	0R Jumper 0603
3494	4822 051 30102	1k 5% 0,062W	4403	4822 051 30008	0R Jumper 0603
3495	4822 051 30102	1k 5% 0,062W	4404	4822 051 30008	0R Jumper 0603
3496	4822 051 30102	1k 5% 0,062W	4410	4822 051 30008	0R Jumper 0603
3497	4822 051 30102	1k 5% 0,062W	4411	4822 051 30008	0R Jumper 0603
3498	4822 051 30102	1k 5% 0,062W	4420	4822 051 30008	0R Jumper 0603
3499	4822 051 30102	1k 5% 0,062W	4421	4822 051 30008	0R Jumper 0603
3500	4822 051 30102	1k 5% 0,062W	4422	4822 051 30008	0R Jumper 0603
3501	4822 051 30102	1k 5% 0,062W	4423	4822 051 30008	0R Jumper 0603
3502	4822 051 30102	1k 5% 0,062W	4424	4822 051 30008	0R Jumper 0603
3503	4822 051 30102	1k 5% 0,062W	4425	4822 051 30008	0R Jumper 0603
3504	4822 051 30102	1k 5% 0,062W	4426	4822 051 30008	0R Jumper 0603
3505	4822 051 30102	1k 5% 0,062W	4427	4822 051 30008	0R Jumper 0603
3506	4822 051 30102	1k 5% 0,062W	4428	4822 051 30008	0R Jumper 0603
3507	4822 051 30102	1k 5% 0,062W	4429	4822 051 30008	0R Jumper 0603
3508	4822 051 30102	1k 5% 0,062W	4430	4822 051 30008	0R Jumper 0603
3509	4822 051 30102	1k 5% 0,062W	4431	4822 051 30008	0R Jumper 0603
3510	4822 051 30102	1k 5% 0,062W	4432	4822 051 30008	0R Jumper 0603
3511	4822 051 30102	1k 5% 0,062W	4433	4822 051 30008	0R Jumper 0603
3512	4822 051 30102	1k 5% 0,062W	4434	4822 051 30008	0R Jumper 0603
3513	4822 051 30102	1k 5% 0,062W	4435	4822 051 30008	0R Jumper 0603
3514	4822 051 30102	1k 5% 0,062W	4436	4822 051 30008	0R Jumper 0603
3515	4822 051 30102	1k 5% 0,062W	4437	4822 051 30008	0R Jumper 0603
3516	4822 051 30102	1k 5% 0,062W	4438	4822 051 30008	0R Jumper 0603
3517	4822 051 30102	1k 5% 0,062W	4439	4822 051 30008	0R Jumper 0603
3518	4822 051 30102	1k 5% 0,062W	4440	4822 051 30008	0R Jumper 0603
3519	4822 051 30102	1k 5% 0,062W	4441	4822 051 30008	0R Jumper 0603
3520	4822 051 30102	1k 5% 0,062W	4442	4822 051 30008	0R Jumper 0603
3521	4822 051 30102	1k 5% 0,062W	4443	4822 051 30008	0R Jumper 0603
3522	4822 051 30102	1k 5% 0,062W	4444	4822 051 30008	0R Jumper 0603
3523	4822 051 30102	1k 5% 0,062W	4445	4822 051 30008	0R Jumper 0603
3524	4822 051 30102	1k 5% 0,062W	4446	4822 051 30008	0R Jumper 0603
3525	4822 051 30102	1k 5% 0,062W	4447	4822 051 30008	0R Jumper 0603
3526	4822 051 30471	470R 5% 0,062W	4448	4822 051 30008	0R Jumper 0603
3527	4822 051 30471	470R 5% 0,062W	4449	4822 051 30008	0R Jumper 0603
3528	4822 051 30103	10k 5% 0,062W	4450	4822 051 30008	0R Jumper 0603
3529	4822 051 30103	10k 5% 0,062W	4451	4822 051 30008	0R Jumper 0603
3530	4822 051 30103	10k 5% 0,062W	4452	4822 051 30008	0R Jumper 0603
3531	4822 051 30103	10k 5% 0,062W	4453	4822 051 30008	0R Jumper 0603
3532	4822 052 10688 Δ	6R8 5% 0,33W	4454	4822 051 30008	0R Jumper 0603

ELECTRICAL PARTS LIST - FRONT BOARD

RESISTORS

4455	4822 051 30008	0R Jumper 0603	7406	4822 130 60373	BC857B
4456	4822 051 30008	0R Jumper 0603	7407	4822 209 15449	74HC4094D
4457	4822 051 30008	0R Jumper 0603			
4458	4822 051 30008	0R Jumper 0603			
4459	4822 051 30008	0R Jumper 0603			
4460	4822 051 30008	0R Jumper 0603			
4461	4822 051 30008	0R Jumper 0603			
4462	4822 051 30008	0R Jumper 0603			

Note : Only the parts mentioned in this list are normal service spare parts.

COILS & FILTERS

5300	3198 018 52280	Coil 2,2uH 10%
5301	3198 018 52280	Coil 2,2uH 10%
5302	3198 018 52280	Coil 2,2uH 10%
5401	3198 018 54780	Coil 4,7uH 10%
5402	3198 018 54780	Coil 4,7uH 10%
5403	2422 543 01069	RES XTL 32,768kHz
5404	5322 242 73686	RES CER 12MHz
5405	4822 242 11033	RES XTL 4,332MHz /22
5406	3198 018 52280	Coil 2,2uH 10% /22
5407	3198 018 52280	Coil 2,2uH 10%
5408	3198 018 54780	Coil 4,7uH 10%
5409	3198 018 54780	Coil 4,7uH 10%
5410	3198 018 54780	Coil 4,7uH 10%
5411	3198 018 54780	Coil 4,7uH 10%

DIODES

6300	4822 130 30621	1N4148
6301	9322 179 76676	LED VS LTL-816EELC
6302	9322 178 15676	LED VS LTL-8166FTNN
6303	9322 178 15676	LED VS LTL-8166FTNN
6304	9322 178 15676	LED VS LTL-8166FTNN
6305	9322 178 15676	LED VS LTL-8166FTNN
6306	9322 178 15676	LED VS LTL-8166FTNN
6307	9322 178 15676	LED VS LTL-8166FTNN
6401	4822 130 30621	1N4148
6403	4822 130 31878	1N4003G
6404	4822 130 34278	BZX79-B6V8
6405	4822 130 31878	1N4003G
6406	4822 130 31878	1N4003G
6407	4822 130 30621	1N4148
6408	4822 130 30621	1N4148
6409	4822 130 30621	1N4148
6410	4822 130 30621	1N4148

TRANSISTORS & INTEGRATED CIRCUITS

7301	9322 185 97667	IR Receiver TSOP4836ZC1
7400	3140 110 52111	MCU TMP88CU74YF MCM530&M590
7401	9322 145 26668	M24C02-WMN6
7403	9352 686 05118	SAA6581T /22
7404	5322 130 60159	BC847B
7405	5322 130 60159	BC847B

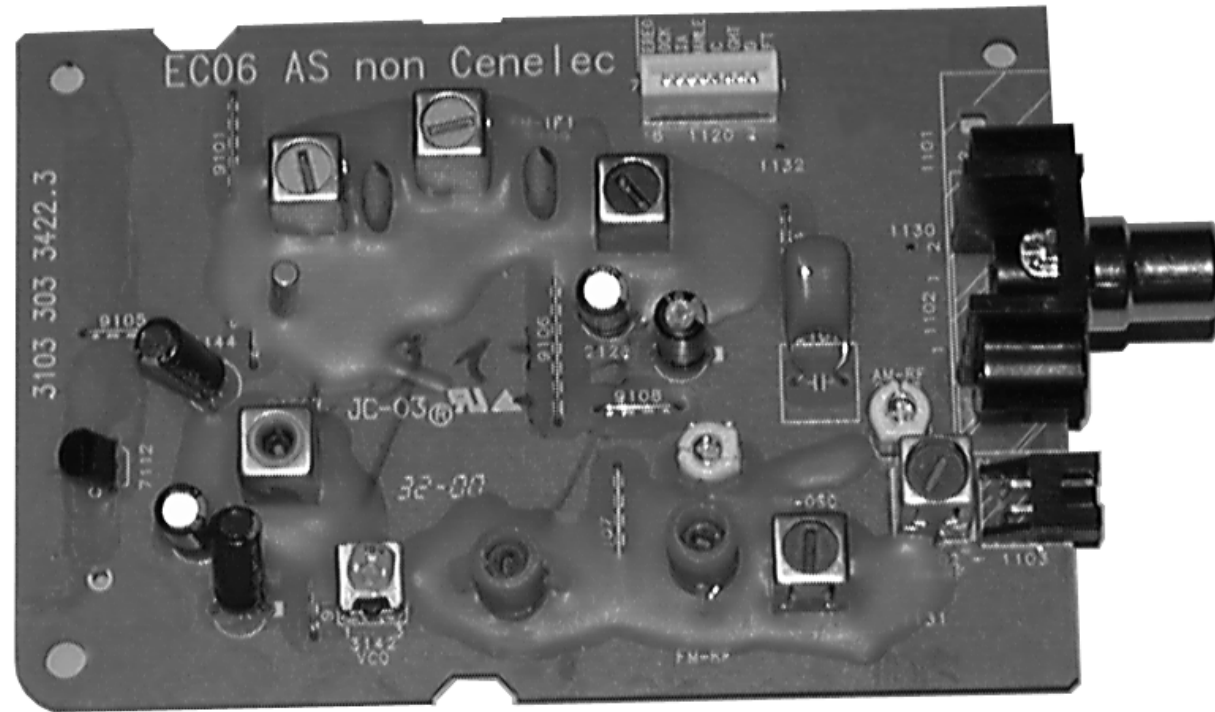

BLOCK DIAGRAM

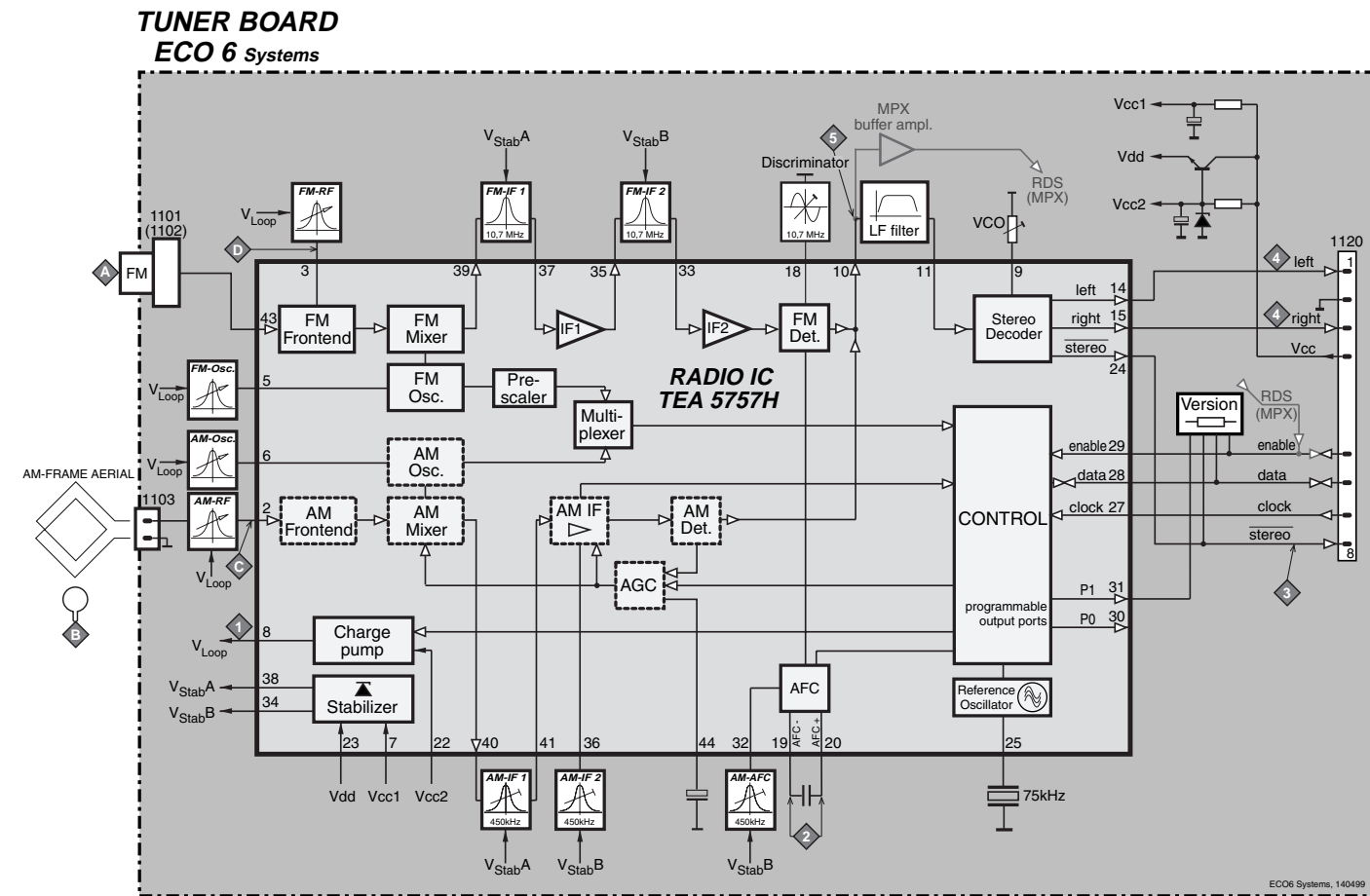

ECO6 Tuner Board
version: **SYSTEMS non-CENELEC**

TABLE OF CONTENTS

Blockdiagram7A-1
 Schematic Diagram7A-2
 Component Layout.....7A-3
 Adjustment table7A-3
 Electrical Partslist.....7A-4

TUNER BOARD ECO6 / SYSTEMS NON CENELEC

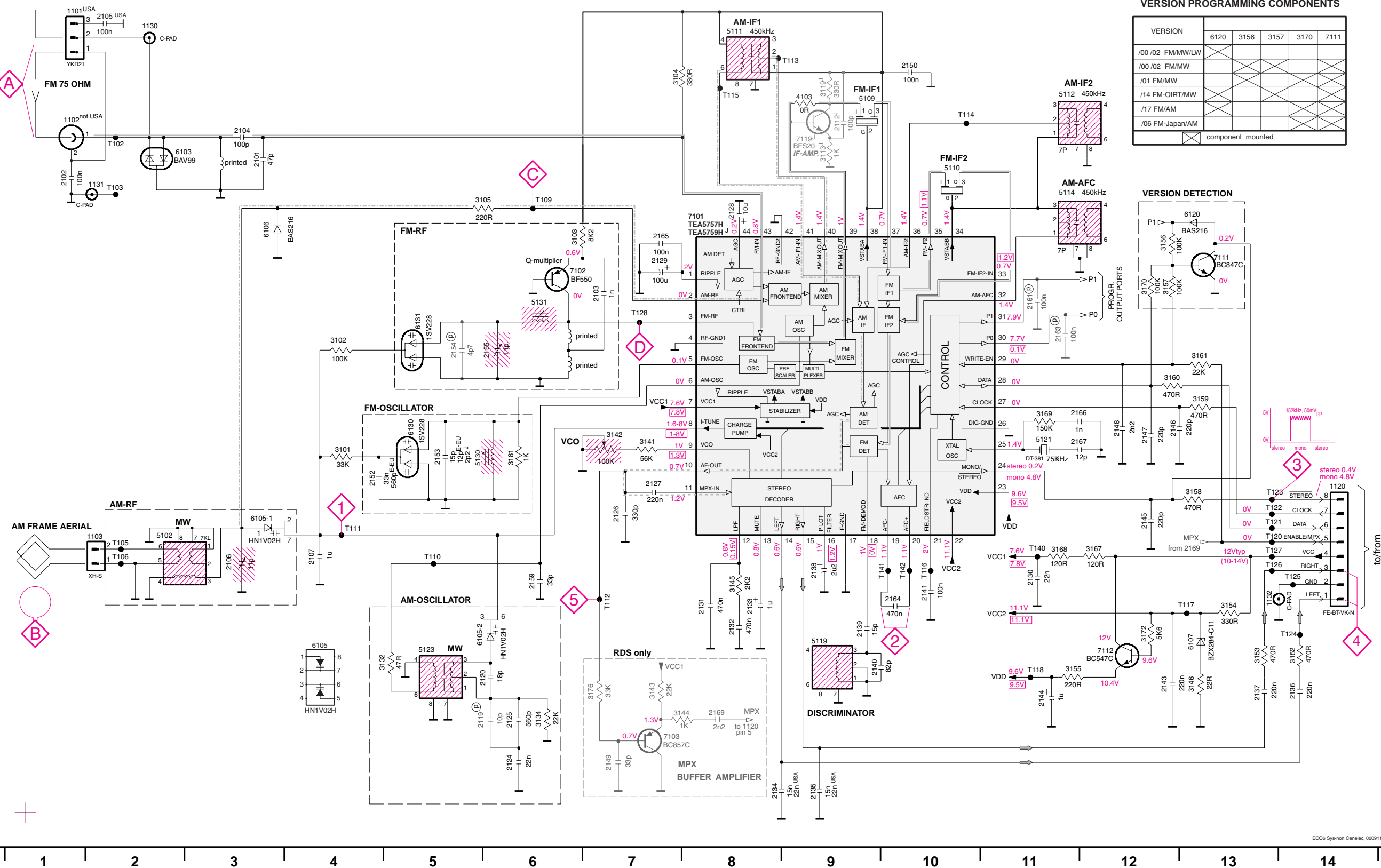

VERSION PROGRAMMING COMPONENTS

VERSION	6120	3156	3157	3170	7111
/00 /02 FM/MW/LW					
/00 /02 FM/MW					
/01 FM/MW					
/14 FM-OIRT/MW					
/17 FM/AM					
/06 FM-Japan/AM					

component mounted

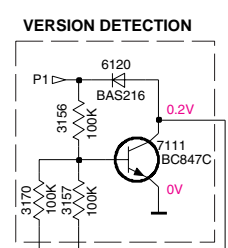

- 1101 A1
- 1102 B1
- 1103 F2
- 1120 E14
- 1130 A2
- 1131 B2
- 1132 G13
- 1133 B3
- 2102 B1
- 2103 C7
- 2104 B3
- 2105 A2
- 2106 F3
- 2107 F4
- 2119 H6
- 2120 G6
- 2124 H6
- 2125 H6
- 2126 F7
- 2127 E7
- 2128 C8
- 2129 C7
- 2130 F11
- 2131 G8
- 2132 G8
- 2133 G8
- 2134 H8
- 2135 H9
- 2136 G14
- 2137 G13
- 2138 F9
- 2139 G9
- 2140 G9
- 2141 F10
- 2143 G12
- 2144 G11
- 2145 F12
- 2146 E12
- 2147 E12
- 2148 H7
- 2149 H7
- 2150 A10
- 2152 E4
- 2153 E5
- 2154 D5
- 2155 D5
- 2159 F6
- 2161 C11
- 2163 D11
- 2164 F10
- 2165 C7
- 2166 E11
- 2167 E11
- 2169 H8
- 3101 E4
- 3102 D4
- 3103 C6
- 3104 A7
- 3105 B6
- 3132 G5
- 3134 H6
- 3141 E7
- 3142 E7
- 3143 G7
- 3144 H7
- 3145 F8
- 3146 G13
- 3152 G14
- 3153 G13
- 3154 G13
- 3155 G11
- 3156 C12
- 3157 D12
- 3158 E13
- 3159 D13
- 3160 D13
- 3161 D13
- 3167 F12
- 3168 F11
- 3169 E11
- 3170 C12
- 3172 G12
- 3176 G7
- 3181 E6
- 5102 F2
- 5109 B9
- 5110 B10
- 5111 A8
- 5112 A11
- 5114 B11
- 5119 G9
- 5121 E11
- 5123 G5
- 5130 E5
- 5131 C6
- 5132 B2
- 6105-1 F3
- 6105-2 G5
- 6106 C3
- 6107 G13
- 6120 G13
- 6130 E5
- 6131 D5
- 7101 C8
- 7102 C6
- 7103 H7
- 7111 C13
- 7112 F13
- 7113 F13
- 7127 F13
- T102 B2
- T103 B2
- T105 F2
- T106 F2
- T109 B6
- T110 F5
- T111 F4
- T112 F7
- T113 A8
- T114 B10
- T115 A8
- T116 F10
- T117 G10
- T118 G11
- T120 F13
- T121 F13
- T122 F13
- T123 E13
- T124 G14
- T125 F14
- T126 F13
- T127 F13
- T128 D7
- T140 F11
- T141 F10
- T142 F10

LEGEND
 (P)...for provision only
 USA ... for USA version only
 E-EU ... for East European version only
 J ... for Japanese version only

...V FM mode stereo
 ...V MW mode
 ...V LW mode
 voltages measured while set is tuned to a strong transmitter

Signal path
 — FM
 - - - AM
 ···· MPX (Audio Frequency)
 ⇨ AF - left/right

1101 A6 1120 A4 1132 A5 2128 C4 2138 C2 3142 D2 5110 B3 5114 A2 5123 D5 7112 C1 9104 B5 9107 D4
 1102 B6 1130 B5 2106 C5 2129 B4 2144 B2 5102 D6 5111 B4 5119 C2 5130 D3 9101 A2 9105 B1 9108 C4
 1103 D6 1131 D5 2107 B5 2133 D2 2155 C4 5109 A3 5112 A3 5121 B2 5131 D4 9103 B2 9106 B3 9109 D2

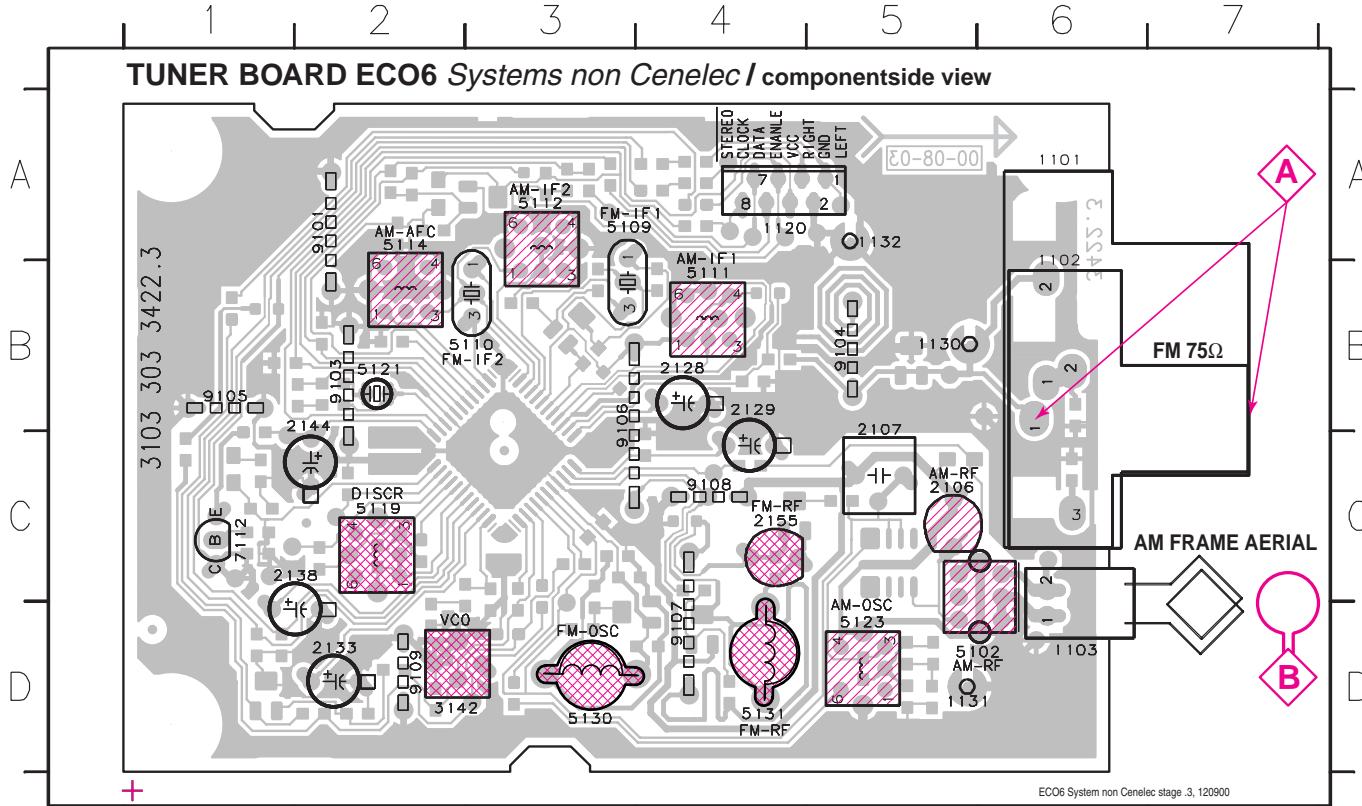

2101 B4 2119 D3 2130 D5 2137 A4 2146 B7 2153 C5 2165 C4 3103 C4 3134 D3 3152 A4 3158 A4 3169 B6 4106 C4 6107 C7 7103 D7
 2102 B1 2120 D3 2131 C5 2139 C6 2147 A5 2154 C4 2166 B6 3104 B4 3141 C5 3153 A4 3159 A5 3170 A6 4107 C5 6120 A6 7111 A5
 2103 D4 2124 D3 2132 D6 2140 C6 2148 B6 2159 C5 2167 B6 3105 C4 3143 D6 3154 C7 3160 A5 3172 C7 4108 C5 6130 D4 7119 B5
 2104 B4 2125 D3 2134 D7 2141 C6 2149 D6 2161 A6 2169 A4 3113 B5 3144 B7 3155 C7 3161 A5 3176 D6 6103 B3 6131 C4
 2105 C1 2126 D6 2135 D7 2143 C7 2150 B5 2163 B6 3101 D5 3119 B5 3145 C5 3156 A6 3167 B7 3181 D4 6105 C3 7101 C5
 2112 B5 2127 C5 2136 A4 2145 A5 2152 C5 3102 C3 3132 D5 3146 C7 3157 A6 3168 C7 4103 B5 6106 C3 7102 D4

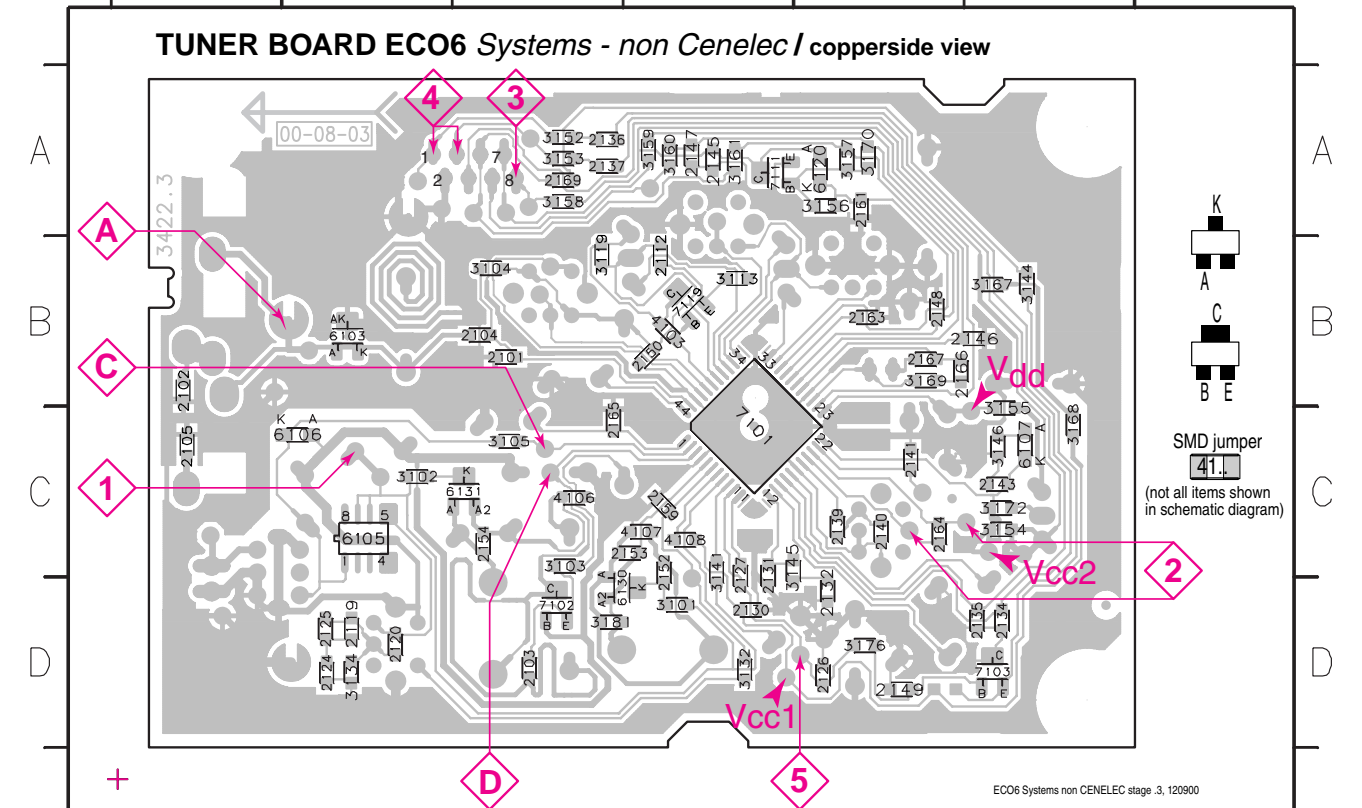

These assembly drawings show a summary of all possible versions.
 For components used in a specific version see schematic diagram respectively partlist.

TUNER ADJUSTMENT TABLE (ECO6 FM/MW- and FM/MW/LW - versions with AM-frame aerial)

Waverange	Input frequency	Input	Tuned to	Adjust	Output	Scope/Voltmeter
VARICAP ALIGNMENT						
FM 87.5 - 108MHz (65.81 - 74, 87.5 - 108MHz)			108MHz	5130		8V ±0.2V
			87.5MHz (65.81MHz)	check		4.3V ±0.5V (1.2V ±0.5V)
MW FM/AM-version, 10kHz grid 530 - 1700kHz			1700kHz	5123		8V ±0.2V
			530kHz	check		1.1V ±0.4V
FM/MW-version, 9kHz grid 531 - 1602kHz			1602kHz	5123	1	6.9V ±0.2V
			531kHz	check		1.1V ±0.4V
LW 153 - 279kHz			279kHz	5122		8V ±0.2V
			153kHz	check		1.1V ±0.4V
MW FM/MW/LW- version, 9kHz grid 531 - 1602kHz			1602kHz	5123		8V ±0.2V
			531kHz	check		1.1V ±0.4V
FM IF						
FM	10.7MHz, 45mV continuous wave	D		5119	2	0 ± 3 mV DC
FM RF						
FM 87.5 - 108MHz (65.81 - 74, 87.5 - 108MHz)	108MHz	A	108MHz	2155	4	MAX
	87.5MHz (65.81MHz)	mod=1kHz Δf=±22.5kHz	87.5MHz (65.81MHz)	5131		
VCO						
FM	98MHz, 1mV continuous wave	A	98MHz	3142	3	152kHz ±1kHz ¹⁾
AM IF						
MW	450kHz connect pin 6 of IC 7101 (AM Osc.) with 3.3kΩ to Vcc	C		5111	5	
		C		5112		
AM AFC		C		5114	2	0 ± 2 mV DC
AM RF³⁾						
MW⁴⁾ FM/MW/LW- and FM/MW-version (9kHz grid)	1494kHz	B	1494kHz	2106	5	
	531 - 1602kHz		558kHz	5102		
LW	198kHz		198kHz	5103		
MW FM/AM-version, 10kHz grid 530 - 1700kHz	1500kHz	B	1500kHz	2106	5	
	560kHz		560kHz	5102		

Use Service Testprogram. By selecting the TUNER TEST test frequencies will be stored as preset frequencies automatically.

- 1) If sensitivity of frequency counter is too low adjust to max. channel separation (input signal: stereo left 90% + 9%, adjust output on right channel to minimum)
- 2) RC network serves for damping the IF-filter while adjusting the other one.
- 3) For AM RF adjustments the original frame antenna has to be used!
- 4) MW has to be aligned before LW.

↑ Repeat

MISCELLANEOUS

1101	2422 015 19376	SOCKET 2P CLICKFIT	USA only
1102	4822 267 10283	SOCKET COAX, IEC 75Ω	not USA
1103	4822 265 31184	JST CONNECTOR 2 POLE	
1120	4822 265 11515	FFC SOCKET, 8P	

CAPACITORS

2101	4822 126 13692	47pF	1%	63V	
2102	4822 126 13838	100nF	10%	50V	not USA
2103	5322 122 31647	1nF	10%	63V	
2104	5322 122 32531	100pF	5%	50V	
2105	4822 126 13838	100nF	10%	50V	USA only
2106	2020 800 00191	3-11pF TRIMCAP.,N450			
2107	4822 121 51319	1μF	20%	50V	
2120	4822 126 13689	18pF	1%	63V	
2124	5322 122 32654	22nF	10%	63V	
2125	2020 552 96199	560pF	1%	50V	
2126	5322 122 31863	330pF	5%	50V	
2127	4822 126 14076	220nF	20%	25V	
2128	4822 124 40248	10μF	20%	63V	
2129	4822 124 41584	100μF	20%	10V	
2130	5322 122 32654	22nF	10%	63V	
2131	4822 126 13482	470nF	20%	16V	
2132	4822 126 13482	470nF	20%	16V	
2133	4822 124 21913	1μF	20%	63V	
2134	4822 126 13188	15nF	5%	63V	not USA
2134	5322 122 32654	22nF	10%	63V	USA only
2135	4822 126 13188	15nF	5%	63V	not USA
2135	5322 122 32654	22nF	10%	63V	USA only
2136	4822 126 14076	220nF	20%	25V	
2137	4822 126 14076	220nF	20%	25V	
2138	4822 124 22652	2,2μF	20%	50V	
2139	4822 126 14236	15pF	5%	50V	
2140	4822 126 13695	82pF	1%	63V	
2141	4822 126 13838	100nF	10%	50V	
2143	4822 126 14076	220nF	20%	25V	
2144	4822 124 21913	1μF	20%	63V	
2145	4822 122 33575	220pF	5%	50V	
2146	4822 122 33575	220pF	5%	50V	
2147	4822 122 33575	220pF	5%	50V	
2148	4822 122 33127	2,2nF	10%	63V	
2149	5322 122 32659	33pF	5%	50V	RDS only
2150	4822 126 13838	100nF	10%	50V	
2152	4822 126 12105	33nF	5%	63V	not for East Europe
2152	5322 116 80853	560pF	5%	63V	for East Europe only
2153	4822 126 13486	15pF	2%	63V	not for East Europe
2153	4822 122 33926	12pF	2%	50V	for East Europe only
2155	2020 800 00191	3-11pF TRIMCAP.,N450			
2159	5322 122 32659	33pF	5%	50V	
2164	4822 126 13482	470nF	20%	16V	
2165	4822 126 13838	100nF	10%	50V	
2166	5322 122 31647	1nF	10%	63V	
2167	4822 122 33926	12pF	5%	50V	
2169	4822 122 33127	2,2nF	10%	63V	RDS only

RESISTORS

3101	4822 051 20333	33kΩ	5%	0,1W
3102	4822 117 10837	100kΩ	1%	0,1W
3103	4822 051 20822	8,2kΩ	5%	0,1W
3104	4822 117 13577	330Ω	1%	0,1W
3105	4822 117 11503	220Ω	5%	0,1W
3132	4822 051 20479	47Ω	5%	0,1W
3134	4822 051 20223	22kΩ	5%	0,1W
3141	4822 117 11148	56kΩ	1%	0,1W
3142	4822 100 12159	TRIMPOT. 100kΩ		

RESISTORS

3143	4822 051 20223	22kΩ	5%	0,1W	RDS only
3144	4822 051 10102	1kΩ	2%	0,25W	RDS only
3145	4822 117 11449	2,2kΩ	1%	0,1W	
3146	4822 051 20229	22Ω	5%	0,1W	
3152	4822 051 20471	470Ω	5%	0,1W	
3153	4822 051 20471	470Ω	5%	0,1W	
3154	4822 117 13577	330Ω	1%	0,1W	
3155	4822 117 11503	220Ω	5%	0,1W	
3156	4822 117 10837	100kΩ	1%	0,1W	
3157	4822 117 10837	100kΩ	1%	0,1W	
3158	4822 051 20471	470Ω	5%	0,1W	
3159	4822 051 20471	470Ω	5%	0,1W	
3160	4822 051 20471	470Ω	5%	0,1W	
3161	4822 051 20223	22kΩ	5%	0,1W	
3167	4822 051 20121	120Ω	5%	0,1W	
3168	4822 051 20121	120Ω	5%	0,1W	
3169	4822 051 20154	150kΩ	5%	0,1W	
3170	4822 117 10837	100kΩ	1%	0,1W	
3172	4822 051 20562	5,6kΩ	5%	0,1W	
3176	4822 051 20333	33kΩ	5%	0,1W	RDS only
3181	4822 051 10102	1kΩ	2%	0,25W	
4103	4822 051 20008	CHIP JUMPER 0805			
4106	4822 051 20008	CHIP JUMPER 0805			
4107	4822 051 20008	CHIP JUMPER 0805			
4108	4822 051 20008	CHIP JUMPER 0805			

COILS

5102	4822 157 71634	RF-COIL MW
5109	4822 242 70665	FM-IF FILTER 10,7MHz
5110	4822 242 70665	FM-IF FILTER 10,7MHz
5111	2422 549 44023	AM-IF FILTER 450kHz
5112	4822 157 70302	AM-IF FILTER 450kHz
5114	4822 157 70302	AM-IF FILTER 450kHz
5119	4822 157 11443	DISCRIMINATOR COIL
5121	4822 242 10261	QUARTZ 75kHz
5123	2422 549 44108	RF-COIL, AM-OSCILLATOR
5130	4822 157 11843	RF COIL 1,5 TURNS
5131	4822 157 11843	RF COIL 1,5 TURNS

DIODES

6103	5322 130 34337	BAV99
6105	4822 130 83075	HN1V02H
6106	4822 130 83757	BAS216
6107	9340 386 90115	BZX284-C11
6120	4822 130 83757	BAS216
6130	4822 130 82833	1SV228
6131	4822 130 82833	1SV228

TRANSISTORS

7102	4822 130 42131	BF550
7103	5322 130 42756	BC857C
7111	5322 130 42755	BC847C
7112	4822 130 44503	BC547C

INTEGRATED CIRCUITS

7101	9351 740 80557	TEA5757H/V1, RADIO IC
------	----------------	-----------------------

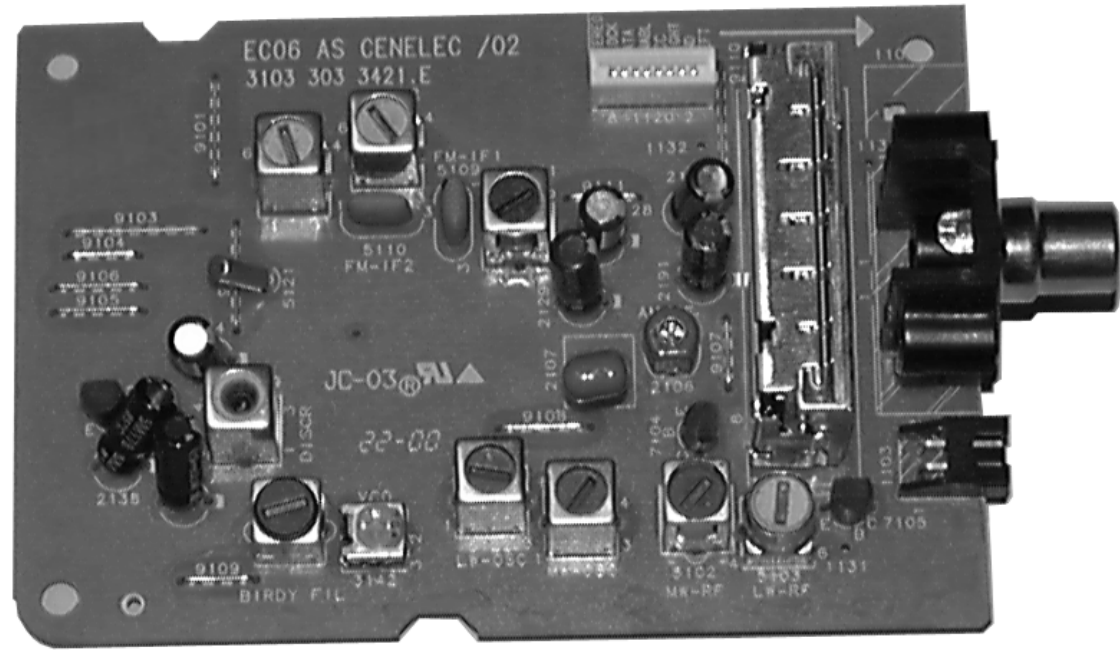

ECO6 Tuner Board

version: **SYSTEMS CENELEC**

TABLE OF CONTENTS

- Blockdiagram7B-1
- Schematic Diagram7B-2
- Component Layout7B-3
- Adjustment table7B-3
- Electrical Partslist7B-4

BLOCK DIAGRAM

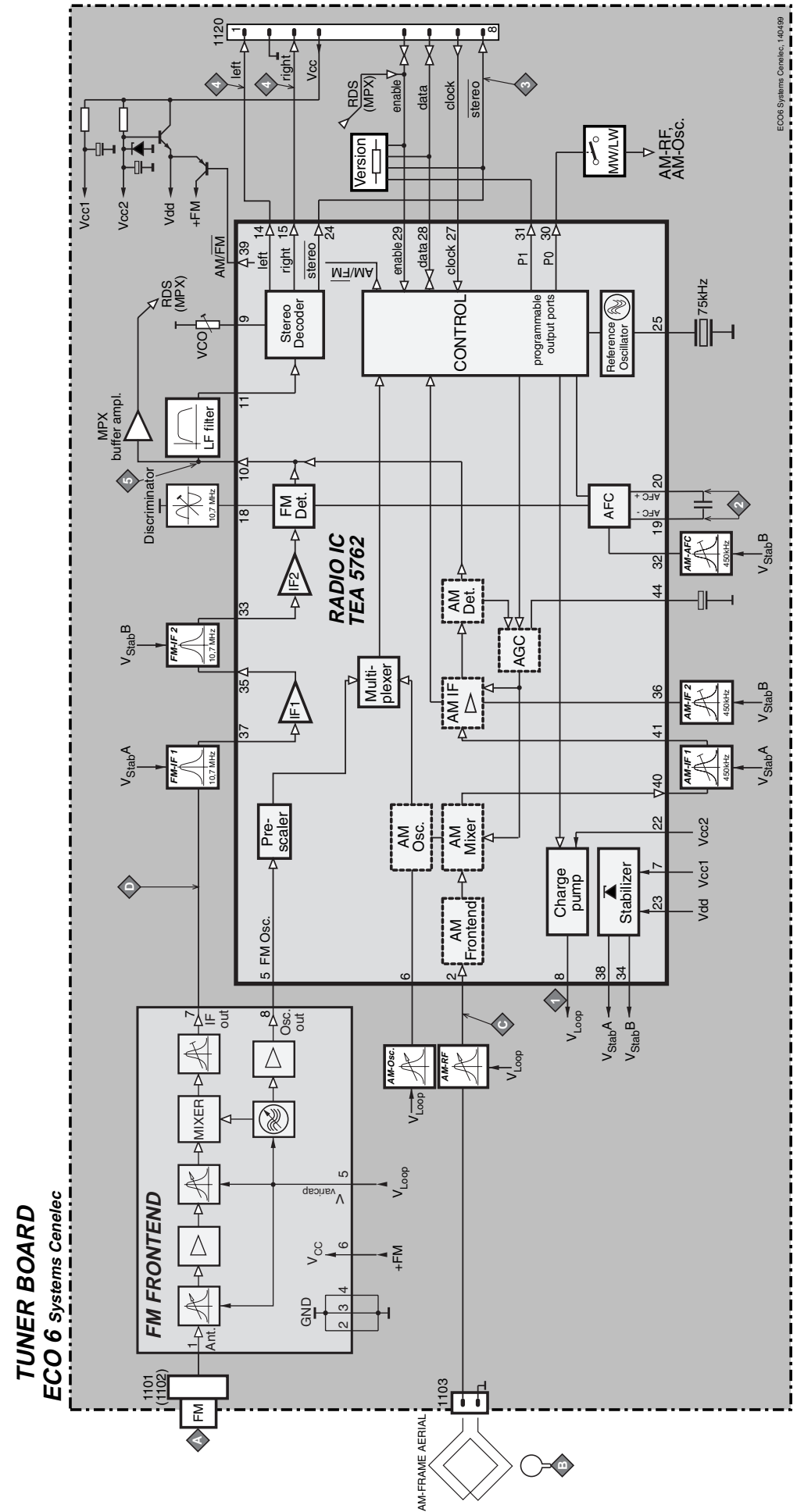

TUNER BOARD ECO6 / SYSTEMS-CENELEC

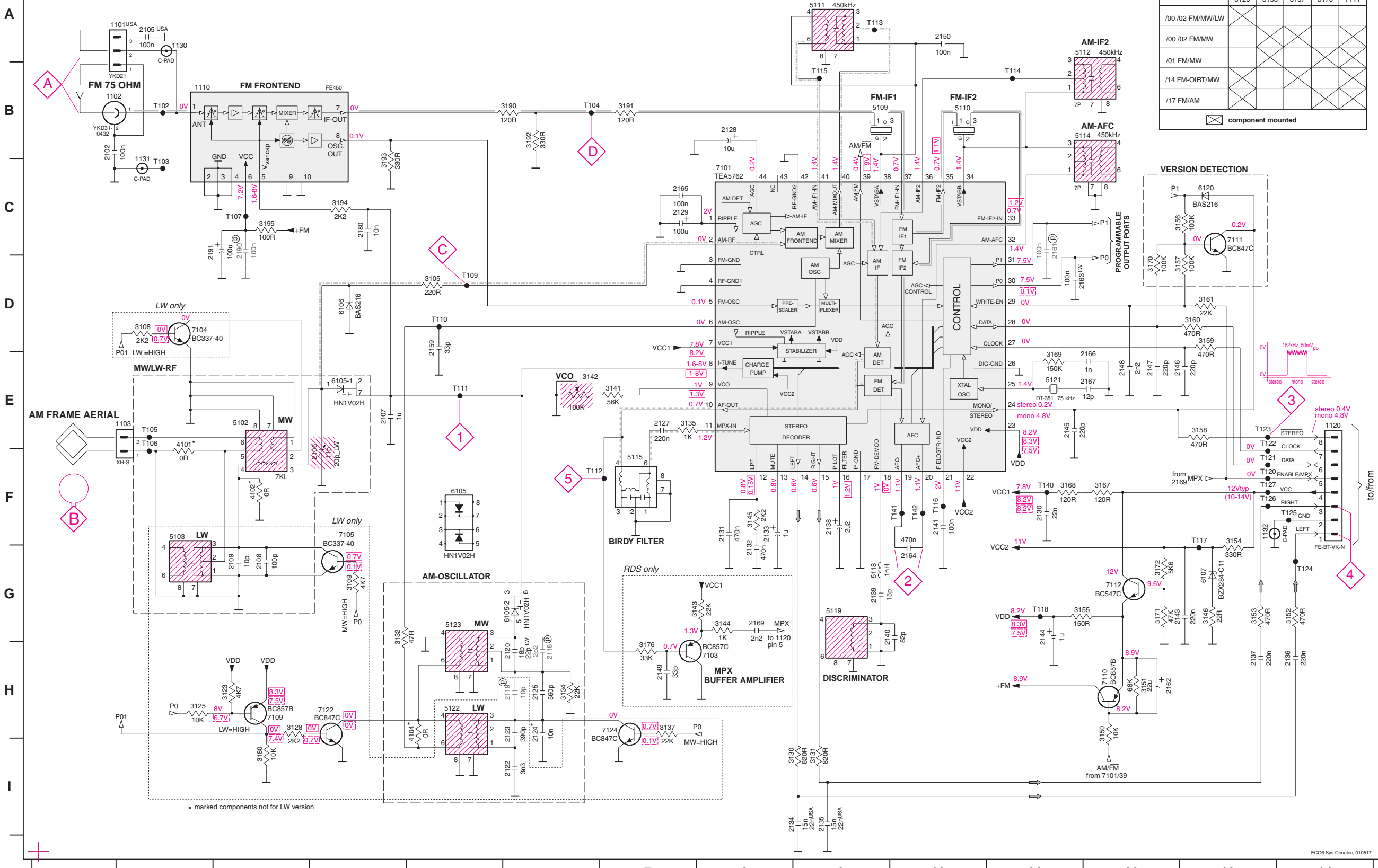

VERSION PROGRAMMING COMPONENTS

VERSION	6120	3156	3157	3170	7111
/00 /02 FM/MW/LW					
/00 /02 FM/MW					
/01 FM/MW					
/14 FM-OIRT/MW					
/17 FM/AM					

component mounted

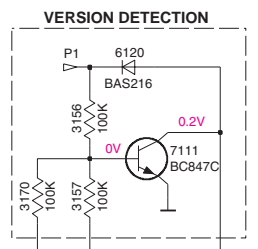

- 1101 A2
- 1102 B1
- 1103 E2
- 1110 B2
- 1120 E14
- 1130 A2
- 1131 C2
- 1132 F13
- 2102 B1
- 2105 A2
- 2106 E3
- 2107 E4
- 2108 G3
- 2109 G3
- 2118 H6
- 2119 H6
- 2120 H6
- 2122 I6
- 2123 H6
- 2124 H6
- 2125 H6
- 2127 E7
- 2128 B8
- 2129 C7
- 2130 F11
- 2131 F8
- 2132 F8
- 2133 F8
- 2134 I8
- 2135 I9
- 2136 H14
- 2137 H13
- 2138 F9
- 2139 G9
- 2140 G9
- 2141 F10
- 2143 G12
- 2144 G11
- 2145 E11
- 2146 E12
- 2147 E12
- 2148 E12
- 2149 H7
- 2150 A10
- 2159 D5
- 2161 C11
- 2162 H12
- 2163 D11
- 2164 G10
- 2165 C7
- 2166 E11
- 2167 E11
- 2169 G8
- 2180 C4
- 2190 C3
- 2191 C3
- 3105 D5
- 3108 D2
- 3109 D4
- 3123 H3
- 3128 H3
- 3130 I9
- 3131 I9
- 3132 G4
- 3134 H6
- 3135 E7
- 3137 H7
- 3141 E7
- 3142 E6
- 3143 G7
- 3144 G8
- 3145 F8
- 3146 G13
- 3150 H12
- 3151 H12
- 3152 G14
- 3153 G13
- 3154 F13
- 3155 G12
- 3156 C12
- 3157 D12
- 3158 E13
- 3159 D13
- 3160 D13
- 3161 D13
- 3167 F12
- 3168 F11
- 3169 E11
- 3170 D12
- 3171 G12
- 3172 G12
- 3176 H7
- 3180 I3
- 3190 B6
- 3191 B7
- 3192 B6
- 3193 B4
- 3194 C4
- 3195 C3
- 4101 E2
- 4102 F3
- 4104 H5
- 5102 E3
- 5103 F2
- 5109 B9
- 5110 B10
- 5111 A9
- 5112 A11
- 5114 B11
- 5115 E7
- 5118 G9
- 5119 G9
- 5121 E11
- 5122 H5
- 5123 G5
- 6105-1 E4
- 6105-2 G6
- 6106 D4
- 6107 G13
- 6120 C13
- 7101 C8
- 7103 H8
- 7104 D2
- 7105 F4
- 7109 H3
- 7110 H12
- 7111 C13
- 7112 G12
- 7112 H12
- 7114 B11
- 7116 F10
- 7117 F13
- 7118 G11
- 7120 F13
- 7121 F13
- 7122 E13
- 7123 E13
- 7124 G14
- 7125 F14
- 7126 F13
- 7127 F13
- 7140 F11
- 7141 F10
- 7142 F10

LEGEND

- * ... only assembled in FM/AM-version
- Ⓧ ... for provision only
- USA ... for USA version only
- LW ... for LW version only
- SMD jumper
- Ⓧ ...V FM mode stereo
- Ⓧ ...V MW mode
- Ⓧ ...V LW mode
- Ⓧ voltages measured while set is tuned to a strong transmitter
- Signal path
- FM
- - - AM
- Ⓧ MPX (Audio Frequency)
- ⇒ AF - left/right

1101 B5 1110 B4 1131 C5 2107 B3 2133 C1 2162 A4 5102 C4 5110 A2 5114 A2 5121 B2 7104 C4 9101 A2 9104 B1 9107 B4 9110 A4
 1102 B5 1120 A4 1132 A4 2128 A3 2138 B1 2191 B4 5103 C4 5111 A3 5115 C2 5122 C3 7105 C5 9102 B2 9105 B1 9108 B3 9111 A3
 1103 C5 1130 A5 2106 B4 2129 B3 2144 B1 3142 C2 5109 B3 5112 A2 5119 B2 5123 C3 7112 B1 9103 A1 9106 B1 9109 C2

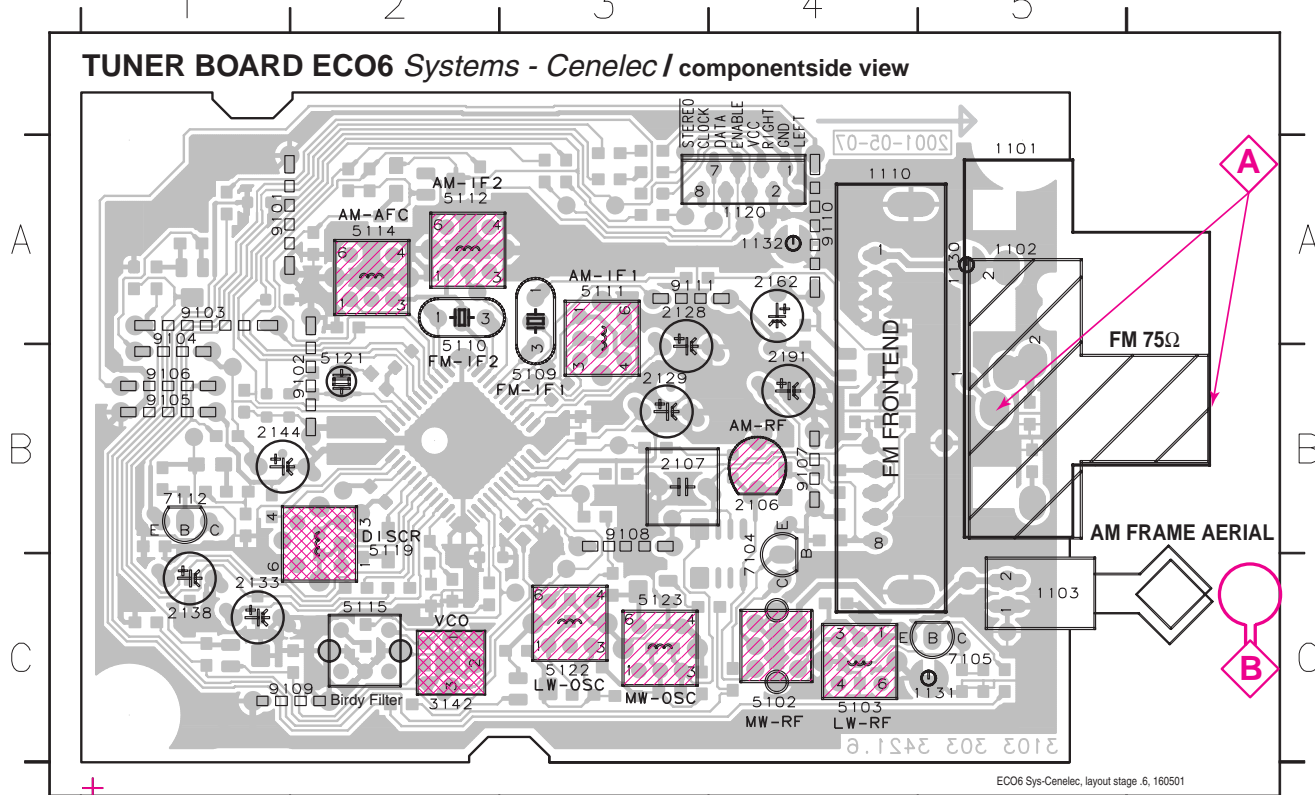

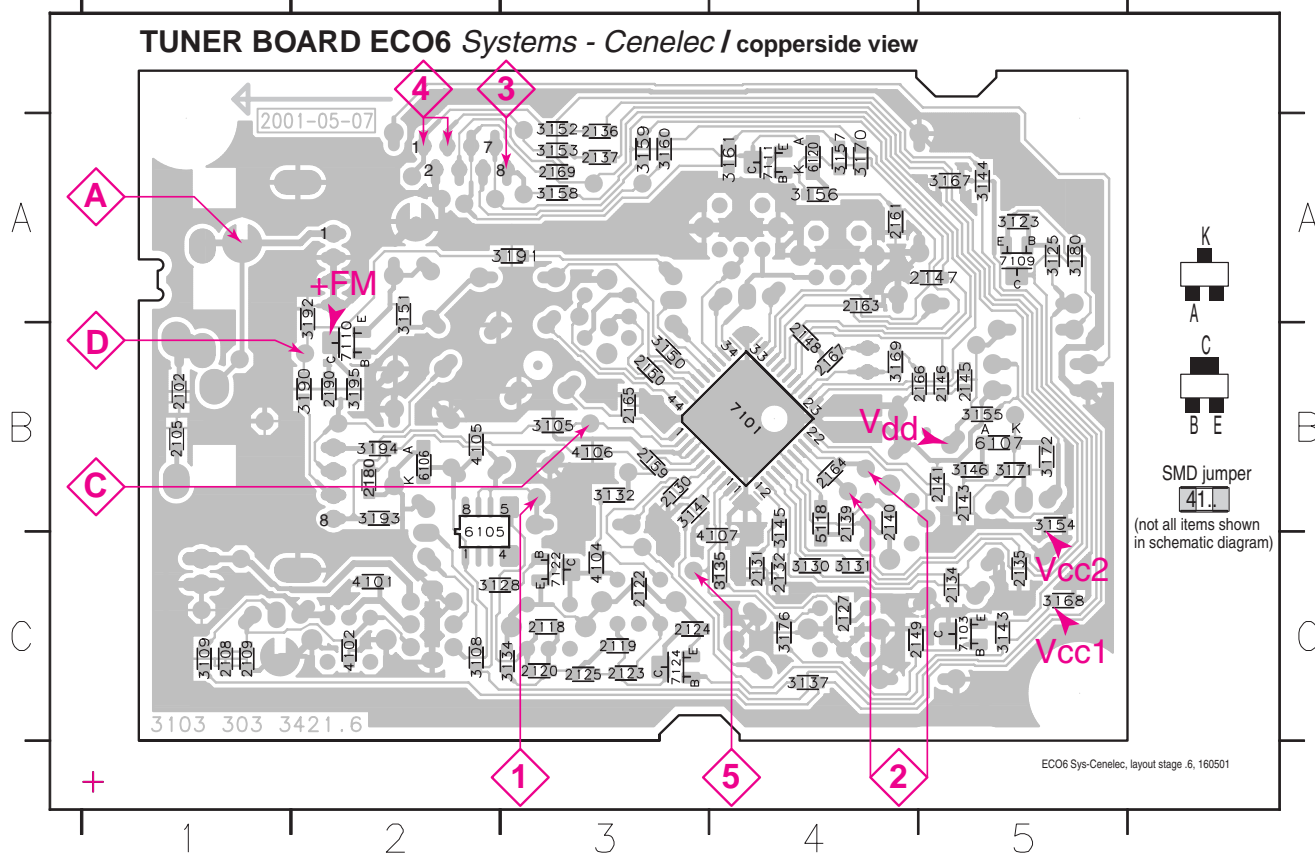

2102 B1 2120 C3 2130 B3 2137 A3 2146 B5 2161 A4 2169 A3 3123 A5 3134 C3 3145 C4 3154 B5 3160 A3 3171 B5 3192 A2 4104 C3 6106 B2 7110 B2
 2105 B1 2122 C3 2131 C4 2139 B4 2147 A5 2163 A4 2180 B2 3125 A5 3135 C4 3146 B5 3155 B5 3161 A4 3172 B5 3193 B2 4105 B2 6107 B5 7111 A4
 2108 C1 2123 C3 2132 C4 2140 B4 2148 B4 2164 B4 2190 B2 3128 C2 3137 C4 3150 B3 3156 A4 3167 A5 3176 C4 3194 B2 4106 B3 6120 A4 7122 C3
 2109 C1 2124 C3 2134 C5 2141 B5 2149 C4 2165 B3 3105 B3 3130 C4 3141 B3 3151 A2 3157 A4 3168 C5 3180 A5 3195 B2 4107 C4 7101 B4 7124 C3
 2118 C3 2125 C3 2135 C5 2143 B5 2150 B3 2166 B5 3108 C2 3131 C4 3143 C5 3152 A3 3158 A3 3169 B4 3190 B2 4101 C2 5118 C4 7103 C5
 2119 C3 2127 C4 2136 A3 2145 B5 2159 B3 2167 B4 3109 C1 3132 B3 3144 A5 3153 A3 3159 A3 3170 A4 3191 A3 4102 C2 6105 B2 7109 A5

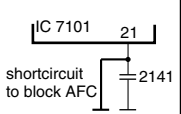
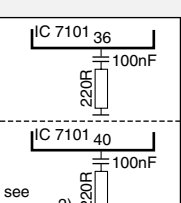
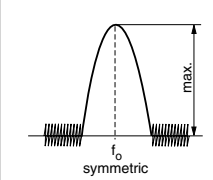

These assembly drawings show a summary of all possible versions.
 For components used in a specific version see schematic diagram respectively partslist.

TUNER ADJUSTMENT TABLE (ECO6 Cenelec FM/MW - and FM/MW/LW - versions with AM-frame aerial)

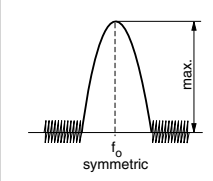
Waverange	Input frequency	Input	Tuned to	Adjust	Output	Scope/Voltmeter
<i>VARICAP ALIGNMENT</i>						
FM 87.5 - 108MHz (50kHz grid)			108MHz	check		8V ±1.2V
			87.5MHz	check		1.6V ±0.5V
MW 531 - 1602kHz (9kHz grid)			1602kHz	5123	1	8V ±0.2V 3-band 6.9V ±0.2V 2-band
			531kHz	check		1.1V ±0.4V
LW 153 - 279kHz (3kHz grid)			279kHz	5122		8V ±0.2V
			153kHz	check		1.1V ±0.4V
<i>FM - IF</i>						
FM	10.7MHz, 45mV continuous wave	D		5119	2	0mV ±3mV
<i>FM - VCO</i>						
FM	98MHz, 1mV continuous wave	A	98MHz	3142	3	152kHz ±1kHz ¹⁾
<i>FM RF (channel separation)</i> Note: The FM-frontend unit has already been adjusted by the factory and needs therefore no further adjustments for service purposes.						
FM	98MHz, 1mV 90% Left + 9% pilot mod=1kHz	A	98MHz	IF coil inside FM frontend 1110	4	right channel min.
<i>AM IF</i>						
MW	450kHz connect pin 6 of IC 7101 (AM Osc.) with 3.3kΩ to Vcc	C $\Delta f = \pm 10\text{kHz}$ $V_{RF} = 0.5\text{mV}$ (as low as possible)		5111	5	
			see remark 2)	5112		
AM AFC MW		C continuous wave $V_{RF} = 2\text{mV}$		5114	2	0mV ±2mV
<i>AM RF ³⁾</i>						
MW	1494kHz	B 	1494kHz	2106	5	
	558kHz		558kHz	5102		
LW	198kHz	$\Delta f = \pm 30\text{kHz}$ V_{RF} as low as possible	198kHz	5103		

Use Service Testprogram. By selecting the TUNER TEST test frequencies will be stored as preset frequencies automatically.

- 1) If sensitivity of frequency counter is too low adjust to max. channel separation (input signal: stereo left 90% + 9%, adjust output on right channel to minimum)
- 2) RC network serves for damping the IF-filter while adjusting the other one.
- 3) For AM RF adjustments the original frame antenna has to be used!
 MW has to be aligned before LW.

↑ Repeat

MISCELLANEOUS

1101	2422 015 19376	SOCKET CLICKFIT 2P	USA only
1102	4822 267 10283	SOCKET COAX, IEC 75Ω	not USA
1103	4822 265 31184	JST CONNECTOR, 2 POLE	
1110	2422 542 90071	FM FRONTEND	
1120	4822 265 11515	FFC SOCKET, 8P	

CAPACITORS

2102	4822 126 13838	100nF 10% 50V	not USA
2105	4822 126 13838	100nF 10% 50V	USA only
2106	2020 800 00204	TRIMCAP. 4.2 - 20pF, N750	LW only
2106	2020 800 00191	TRIMCAP. 3 - 11pF, N450	FM/AM only
2107	4822 121 51319	1μF 20% 50V	
2108	5322 122 32531	100pF 5% 50V	LW only
2109	5322 122 32448	10pF 5% 50V	LW only
2120	4822 126 13689	18pF 1% 63V	FM/AM only
2120	5322 122 32658	22pF 5% 50V	LW only
2122	4822 122 33891	3,3nF 10% 63V	LW only
2123	2020 552 93494	390pF 1% 50V	LW only
2124	4822 122 33177	10nF 20% 50V	FM/AM only
2125	2020 552 96199	560pF 1% 50V	
2127	4822 126 14076	220nF 20% 25V	
2128	4822 124 40248	10μF 20% 63V	
2129	4822 124 41584	100μF 20% 10V	
2130	5322 122 32654	22nF 10% 63V	
2131	4822 126 13482	470nF 20% 16V	
2132	4822 126 13482	470nF 20% 16V	
2133	4822 124 21913	1μF 20% 63V	
2134	3198 017 31530	15nF 10% 50V	not USA
2134	5322 122 32654	22nF 10% 63V	USA only
2135	3198 017 31530	15nF 10% 50V	not USA
2135	3198 017 32230	22nF 10% 25V	USA only
2136	4822 126 14076	220nF 20% 25V	
2137	4822 126 14076	220nF 20% 25V	
2138	4822 124 22652	2,2μF 20% 50V	
2139	4822 126 14236	15pF 5% 50V	
2140	4822 126 13695	82pF 1% 63V	
2141	4822 126 13838	100nF 10% 50V	
2143	4822 126 14076	220nF 20% 25V	
2144	4822 124 21913	1μF 20% 63V	
2145	4822 122 33575	220pF 5% 50V	
2146	4822 122 33575	220pF 5% 50V	
2147	4822 122 33575	220pF 5% 50V	
2148	4822 122 33127	2,2nF 10% 63V	
2149	5322 122 32659	33pF 5% 50V	RDS only
2150	4822 126 13838	100nF 10% 50V	
2159	5322 122 31151	22μF 20% 50V	
2163	4822 126 13838	100nF 10% 50V	LW only
2164	4822 126 13482	470nF 20% 16V	
2165	4822 126 13838	100nF 10% 50V	
2166	5322 122 31647	1nF 10% 63V	
2167	4822 122 33926	12pF 5% 50V	
2169	4822 122 33127	2,2nF 10% 63V	RDS only
2180	3198 017 31030	10nF 10% 50V	
2190	4822 126 13838	100nF 10% 50V	
2191	4822 124 40178	100μF 20% 10V	

RESISTORS

3105	4822 117 11503	220Ω 5% 0,1W	
3108	4822 117 11449	2,2kΩ 1% 0,1W	LW only
3109	4822 051 20472	4,7kΩ 5% 0,1W	LW only
3123	4822 051 20472	4,7kΩ 5% 0,1W	LW only
3125	4822 117 10833	10kΩ 1% 0,1W	LW only

RESISTORS

3128	4822 117 11449	2,2kΩ 1% 0,1W	LW only
3130	3198 021 38210	820Ω 5% 0,06W	
3131	3198 021 38210	820Ω 5% 0,06W	
3132	4822 051 20479	47Ω 5% 0,1W	
3134	4822 051 20223	22kΩ 5% 0,1W	
3135	3198 021 31020	1kΩ 5% 0,06W	
3137	4822 051 20223	22kΩ 5% 0,1W	LW only
3141	4822 117 11148	56kΩ 1% 0,1W	
3142	4822 100 12159	TRIMPOT. 100kΩ	
3143	4822 051 20223	22kΩ 5% 0,1W	RDS only
3144	4822 051 10102	1kΩ 2% 0,25W	RDS only
3145	4822 117 11449	2,2kΩ 1% 0,1W	
3146	4822 051 20229	22Ω 5% 0,1W	
3150	4822 117 10833	10kΩ 1% 0,1W	
3151	4822 051 20683	68kΩ 5% 0,1W	
3152	4822 051 20471	470Ω 5% 0,1W	
3153	4822 051 20471	470Ω 5% 0,1W	
3154	4822 117 13577	330Ω 1% 0,1W	
3155	4822 117 10353	150Ω 5% 0,1W	
3156	4822 117 10837	100kΩ 1% 0,1W	
3157	4822 117 10837	100kΩ 1% 0,1W	
3158	4822 051 20471	470Ω 5% 0,1W	
3159	4822 051 20471	470Ω 5% 0,1W	
3160	4822 051 20471	470Ω 5% 0,1W	
3161	4822 051 20223	22kΩ 5% 0,1W	
3167	4822 051 20121	120Ω 5% 0,1W	
3168	4822 051 20121	120Ω 5% 0,1W	
3169	4822 051 20154	150kΩ 5% 0,1W	
3170	4822 117 10837	100kΩ 1% 0,1W	
3171	4822 117 10834	47kΩ 1% 0,1W	
3172	4822 051 20562	5,6kΩ 5% 0,1W	
3176	4822 051 20333	33kΩ 5% 0,1W	RDS only
3180	4822 117 10833	10kΩ 1% 0,1W	LW only
3190	4822 051 20121	120Ω 5% 0,1W	
3191	4822 051 20121	120Ω 5% 0,1W	
3192	4822 117 13577	330Ω 1% 0,1W	
3193	4822 117 13577	330Ω 1% 0,1W	
3194	4822 117 11449	2,2kΩ 1% 0,1W	
3195	4822 051 20101	100Ω 5% 0,1W	
4101	4822 051 20008	CHIP JUMPER 0805	FM/AM only
4102	4822 051 20008	CHIP JUMPER 0805	FM/AM only
4104	4822 051 20008	CHIP JUMPER 0805	FM/AM only
4105	4822 051 20008	CHIP JUMPER 0805	
4106	4822 051 20008	CHIP JUMPER 0805	
4107	4822 051 20008	CHIP JUMPER 0805	

COILS

5102	4822 157 71634	RF-COIL MW	
5103	2422 549 44107	RF-COIL LW	LW only
5109	4822 157 71639	FM-IF FILTER 10,7MHz	
5110	4822 242 70665	FM-IF FILTER 10,7MHz	
5111	2422 549 44023	AM-IF FILTER 450kHz	
5112	4822 157 70302	AM-IF FILTER 450kHz	
5114	4822 157 70302	AM-IF FILTER 450kHz	
5115	4822 157 71636	ANTI BIRDY FILTER	
5118	2422 535 95881	100nH	
5119	4822 157 11443	DISCRIMINATOR COIL	
5121	4822 242 10261	QUARTZ 75kHz	
5122	2422 549 44108	RF-COIL, LW-OSCILLATOR	LW only
5123	2422 549 44108	RF-COIL, MW-OSCILLATOR	

DIODES

6105	4822 130 83075	HN1V02H	
6106	4822 130 83757	BAS216	
6107	9340 386 90115	BZX284-C11	
6120	4822 130 83757	BAS216	

TRANSISTORS

7103	5322 130 42756	BC857C	RDS only
7104	9322 003 64676	TBC337-40	LW only
7105	9322 003 64676	TBC337-40	LW only
7109	4822 130 60373	BC856B	LW only
7110	4822 130 60373	BC856B	
7111	5322 130 42755	BC847C	
7112	4822 130 44503	BC547C	
7122	5322 130 42755	BC847C	LW only
7124	5322 130 42755	BC847C	LW only

INTEGRATED CIRCUITS

7101	4822 209 90315	TEA5762H/V1, RADIO IC	
------	----------------	-----------------------	--

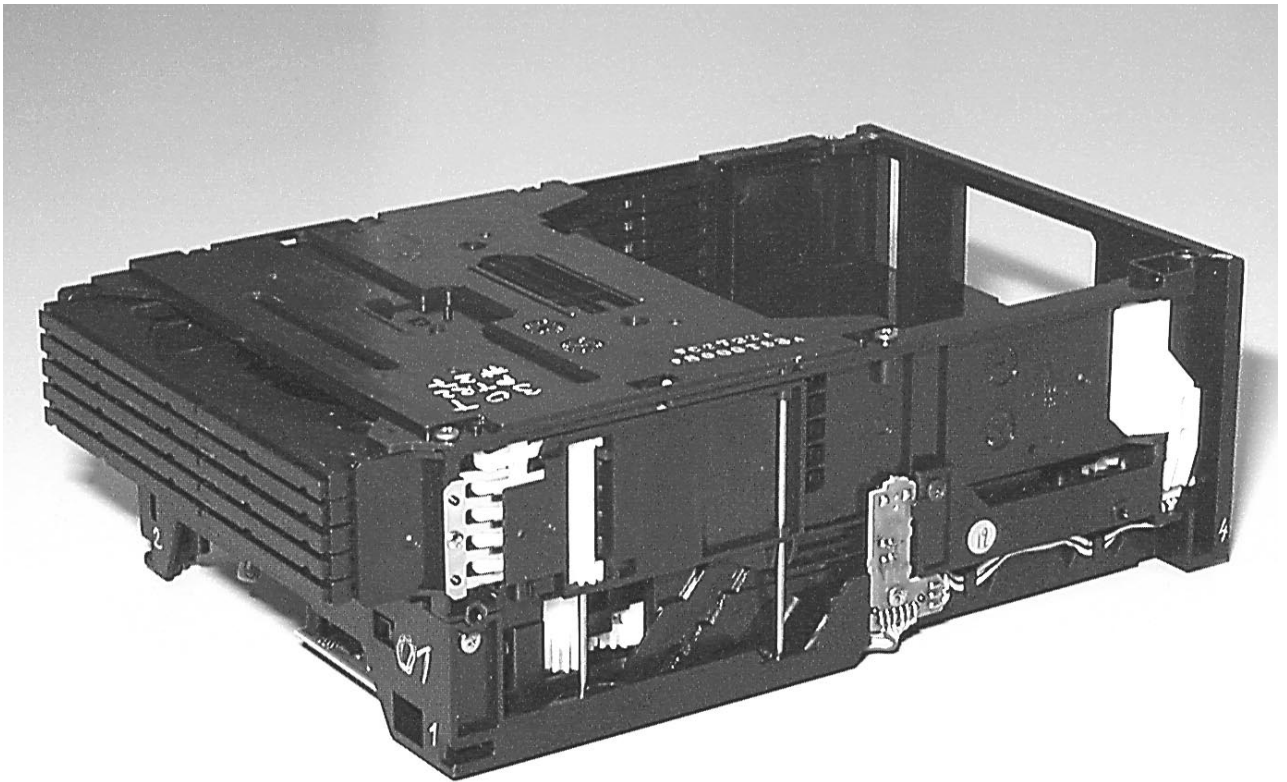

5DTC Module

(MP3 version)

Layout stage .4

TABLE OF CONTENTS

Service hints	10-2
Location of Printed Circuit Boards	10-5
Wiring	10-6
Emergency opening	10-7
Location of switches.....	10-8
Blockdiagram	10-9
CD BOARD	
Circuit Diagram	10-10
Component Layout side A	10-11
Component Layout side B	10-12
CONTROL BOARD	
Circuit Diagram	10-13
Component Layout	10-13
MP3 BOARD	
Circuit Diagram	10-14
Component Layout	10-15
Exploded view loader	10-16
Partslist	10-17

Service Hints

In case of symptom „skipping tracks“ perform following actions:

1. VERIFY THE COMPLAINT

PLAYABILITY CHECK

Use CDDA SBC 444A:4822 397 30245
 TR 14 (600µ black dot) maximum at 01:15
 TR 19 (fingerprint)
 TR 10 (1000µ wedge)

Use CD-RW Printed Audio Disk7104 099 96611
 TR 3 (Fingerprint)
 TR 8 (600µ black dot) maximum at 01:00

- playback of all these tracks without audible disturbance
- jump forward/backward within a reasonable time

2. CLEAN THE LENS

CD DRIVE – LENS CLEANING

Before touching the lens it is advised to clean the surface of the lens by blowing clean air over it in order to avoid that little particles make scratches on the lens.

Because the material of the lens is synthetic and coated with a special anti-reflectivity layer, cleaning must be done with a non-aggressive cleaning fluid. It is advised to use “KODAK LENS CLEANER CAT 176 71 36”, available in normal photo shops.

The actuator is a very precise mechanical component and may not be damaged in order to guarantee its full function. It is advised to clean the lens gently (don't press too hard) with a soft and clean cotton bud moistened with the special lens cleaner.

The direction of cleaning must be in the way as indicated in the picture below.

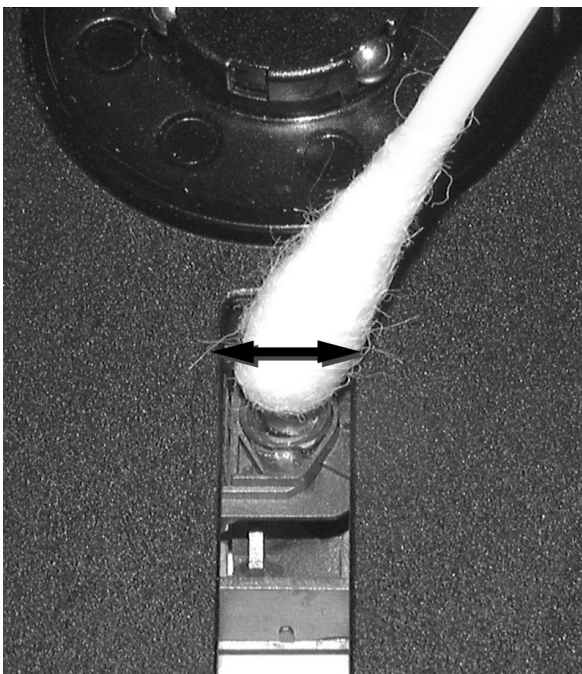

3. MEASURE THE EYE-PATTERN SIGNAL

EYE-PATTERN SIGNAL – JITTER MEASUREMENT

Measure the signal direct on resistor 3898 using an oscilloscope (see also chapter 10-9).

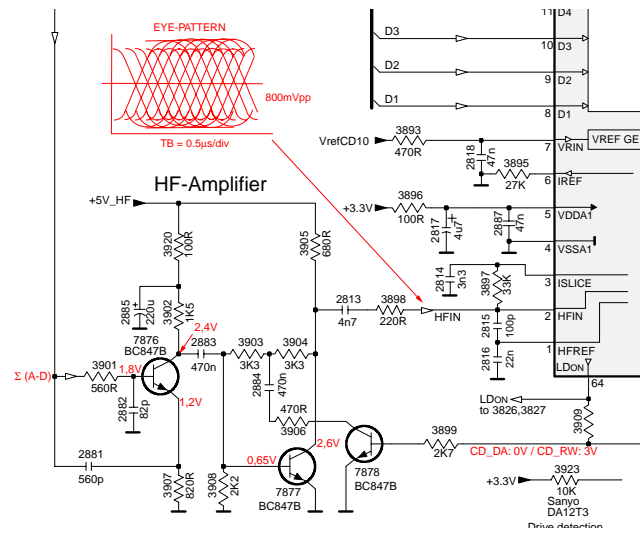

See below examples of the signal. Amplitude should read at least 700mVpp using SBC444A.

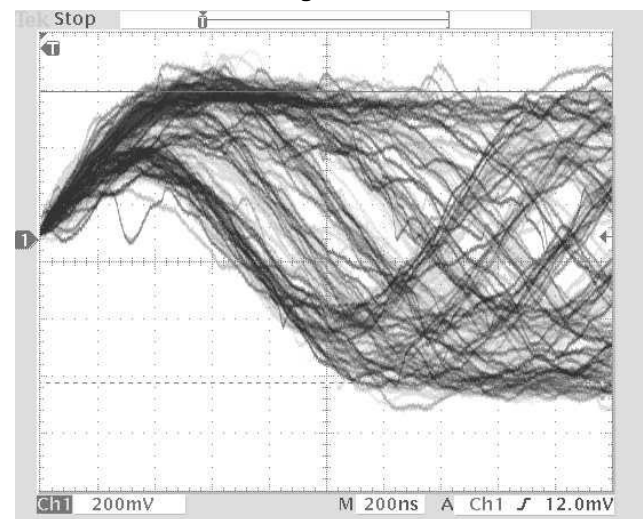
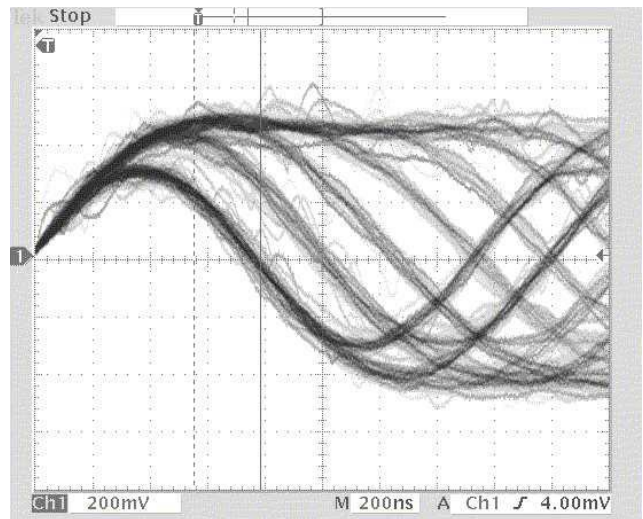

bad
 If the oscilloscope shows a signal like the 'bad' one, and/or the amplitude decreases within 1minute - the CD drive has to be replaced.

4. MEASURE THE LASER CURRENT

CD DRIVE – LASER CURRENT MEASUREMENT

The laser current can be measured as a voltage drop on resistor 3820. Typical value 170 - 190mV for CD-DA respectively 200 - 220mV for CD-RW.

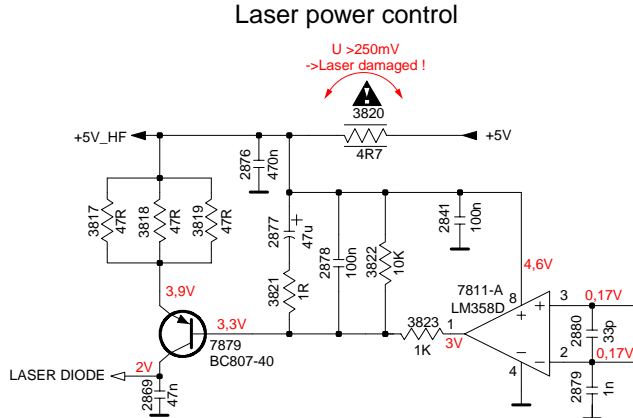

5. MEASURE THE OFFSETS OF THE CD-DRIVE

CD DRIVE – OFFSET MEASUREMENT

Each photodiode of the CD-drive may have an offset. This offset has to be compensated by the signal processor. A high offset of the CD-drive leads to poor playability of some CDs (skipping tracks).

Start the **Service Test Program** - section „Focus Test“ without a CD. Focus sensitivity = CD-RW.

Use a DC Millivoltmeter for measurement. The offsets can be measured direct on the connector. See drawing below.

The values from diode A-D should read $0 \pm 10mV$. Diodes E and F are less critical.

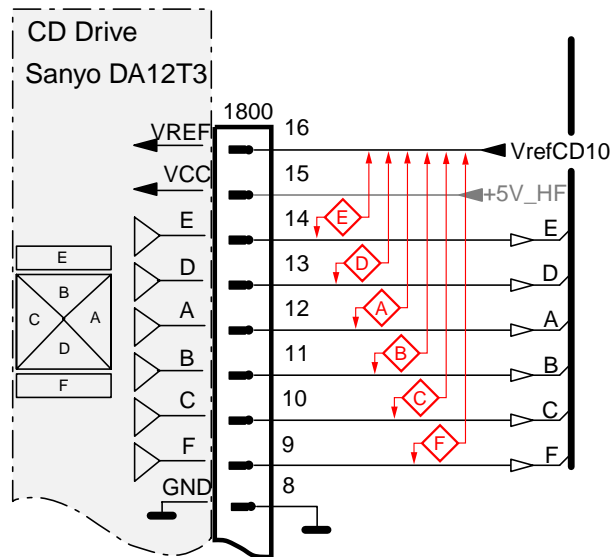

If one of the offsets is higher than $\pm 10mV$ the CD drive has to be replaced.

6. MEASURE THE OFFSETS OF THE CD10

SIGNAL PROCESSOR – OFFSET MEASUREMENT

Each ADC input of the CD10 may have an offset too. Also this offset leads (together with the offsets of the CD Drive) to poor playability of some CDs (skipping tracks).

Start the **Service Test Program** - section „Focus Test“ using a CD-RW disc.

Use a DC Millivoltmeter for measurement. The offsets can be measured on capacitors near the signal processor. See drawing below.

The value should read $0mV \pm 10mV$.

CD Board side A view

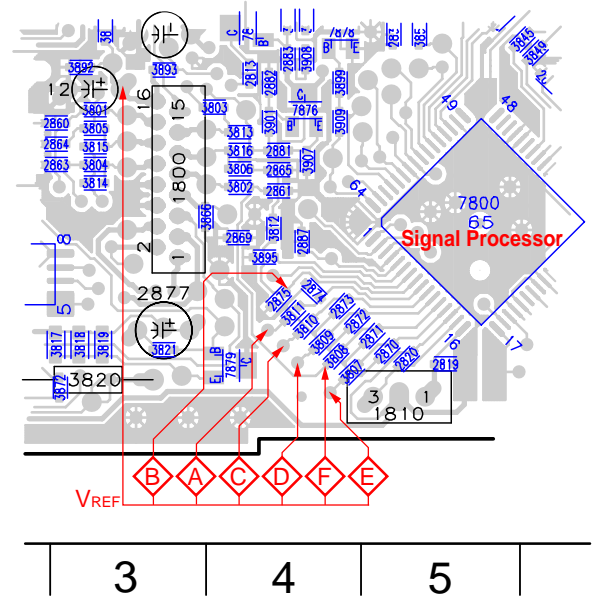

If one of the offsets is higher than $\pm 10mV$ the signal processor has to be replaced.

If none of the measured offsets is higher than $\pm 10mV$ - replace the part with the higher value.

WARNING

CHARGED CAPACITORS ON THE SERVO BOARD MAY DAMAGE THE CD DRIVE ELECTRONICS WHEN CONNECTING A NEW CDM MECHANISM. THAT'S WHY, BESIDES THE SAFETY MEASURES LIKE

- **SWITCH OFF POWER SUPPLY**
- **ESD PROTECTION**

ADDITIONAL ACTIONS MUST BE TAKEN BY THE REPAIR TECHNICIAN.

The CD drive forms a compact building block with the CD Board.

The following steps have to be done when replacing the CD mechanism:

1. Desolder disc and slide motor
2. Loosen 2x screw
1. Disconnect flexfoil from old CD drive
2. Put a paperclip over contacts of flexfoil to short-circuit the contacts (fig.1)
3. Remove old CD drive
4. Mount new CD drive to CD board
5. Solder disc and slide motor **after** fixing the drive to the board
5. Move slide outside
6. Remove paperclip from flexfoil
7. Connect flexfoil to new CD drive
8. Remove ESD-protection (solder joint) from laserunit (see picture below)

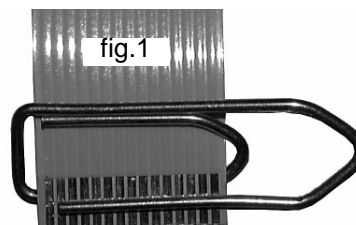

Attention: The laser diode of this CD drive is protected against ESD by a solder joint which shortcircuits the laserdiode to ground. For proper functionality of the CD drive this solder joint must be removed **after** connection the drive to the set.

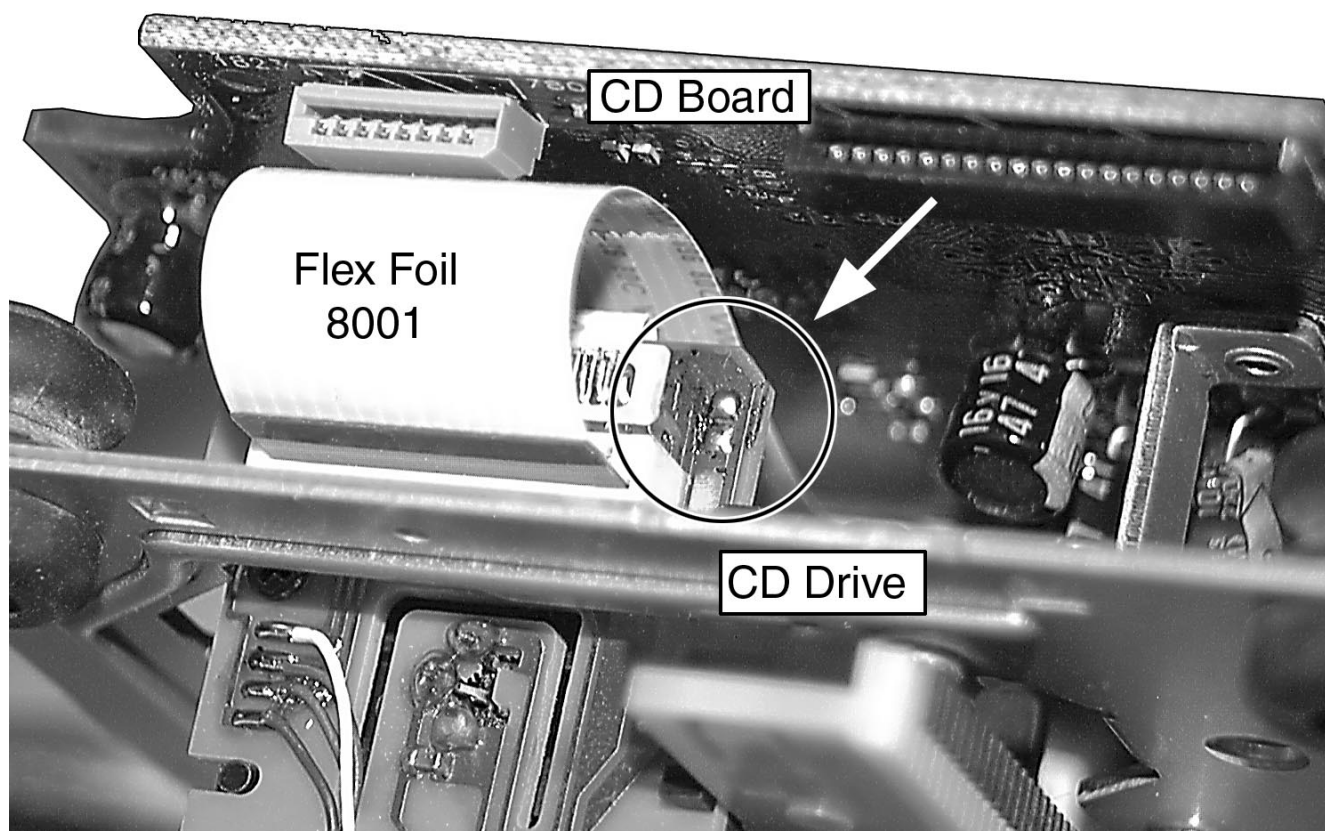

Location of Printed Circuit Boards

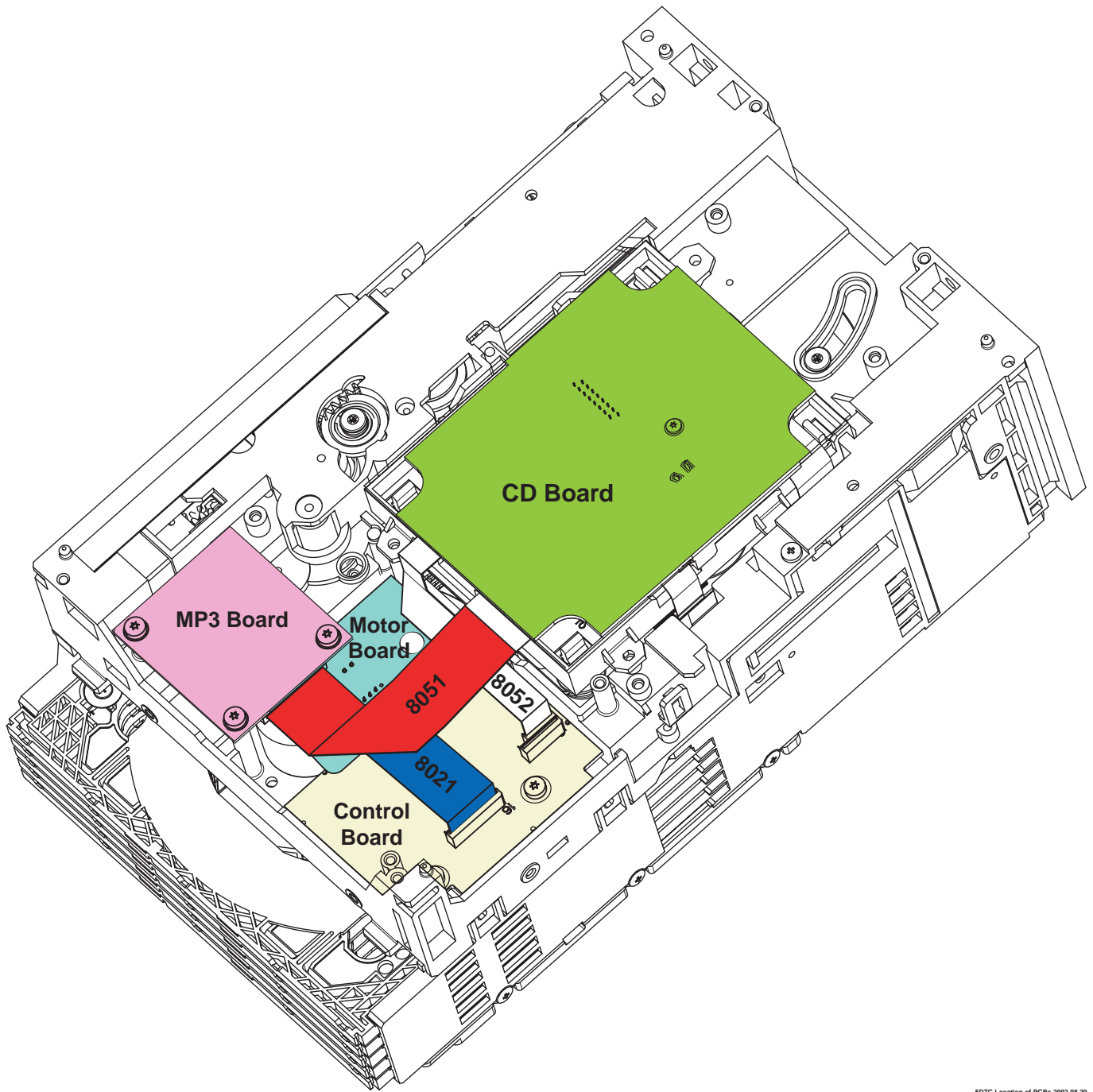

Wiring Diagram 5DTC Module

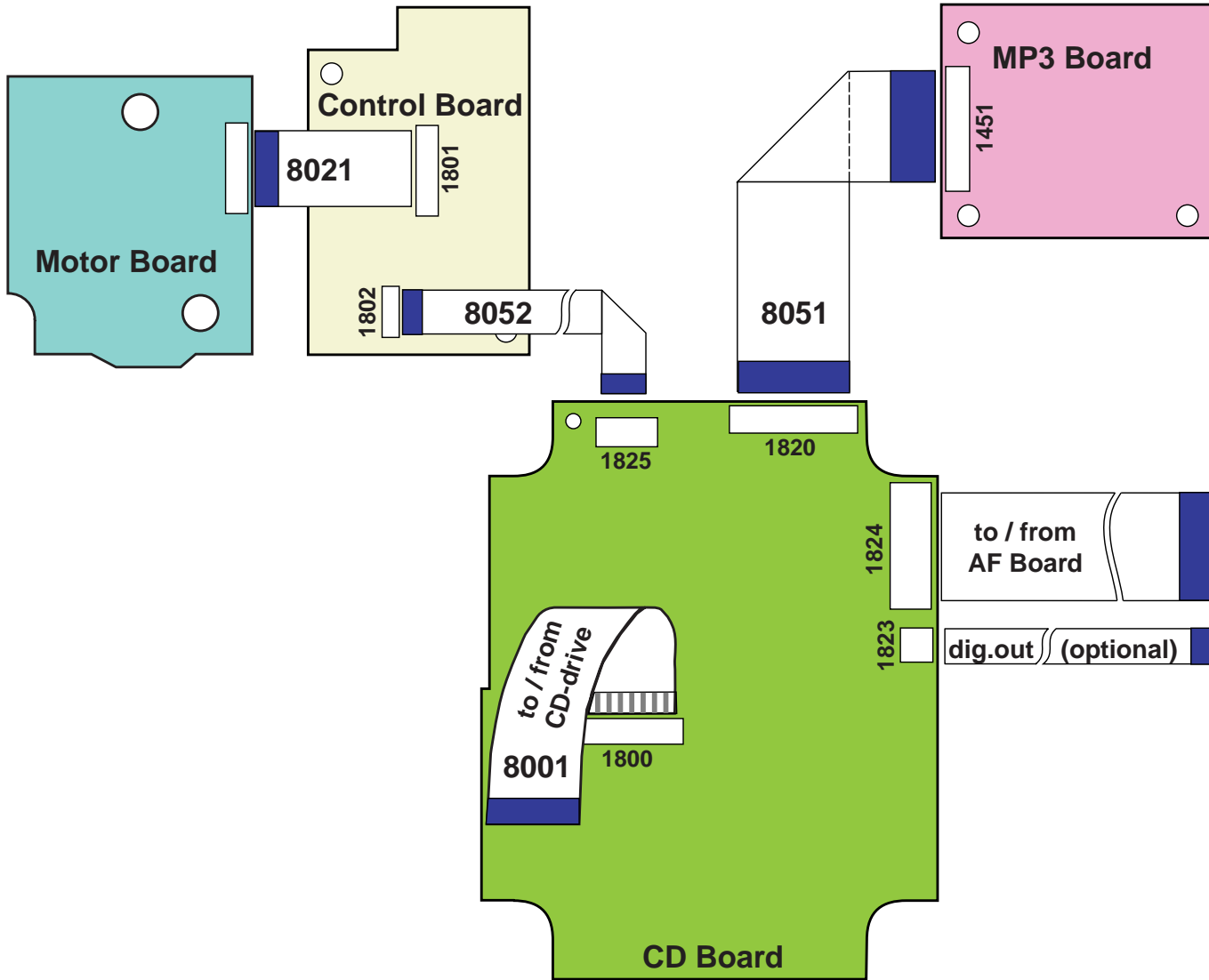

5DTC Wiring Diagram 2002 08 30

The FFC-Cables are available as sparepart.

8001	3103 308 93090	FFC CABLE 16Pin 80mm BD	Connection from CD Board to CD Drive
8051	3103 308 93100	FFC-CABLE 19Pin 90mm AD	Connection from CD Board to MP3 Board
8052	3103 308 93120	FFC CABLE 8Pin 80mm BD	Connection from CD Board to Control Board
8021	3103 308 93110	FFC-CABLE 16Pin 60mm AD	Connection from Control Board to Motor Board

Emergency opening of the trays

The trays of the 5DTC are mechanically locked.

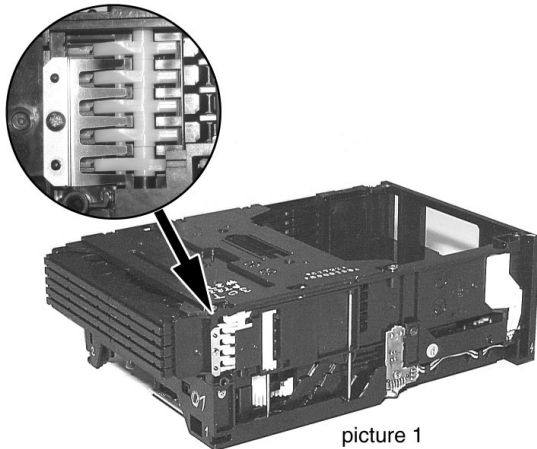

picture 1

To open tray 1, 2 and 3 move lever (pos 29) backwards (e.g. with a screwdriver - see picture 2) to its endposition.

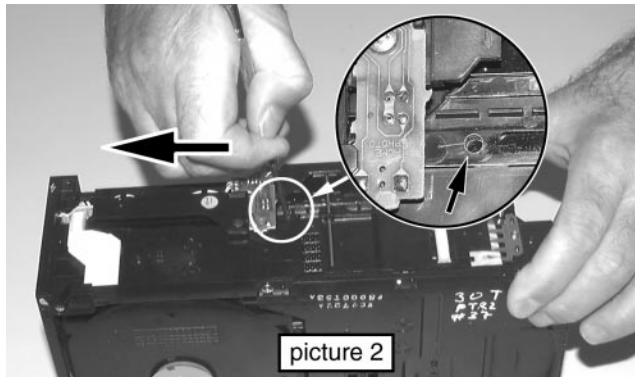

picture 2

Release the locking mechanism and pull out the tray (see picture 3).

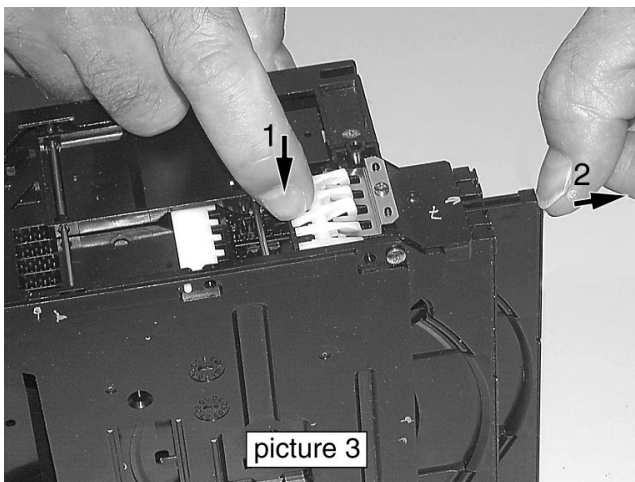

picture 3

To open tray 4 and 5 move lever (pos 29) forward to its endposition (see picture 4).

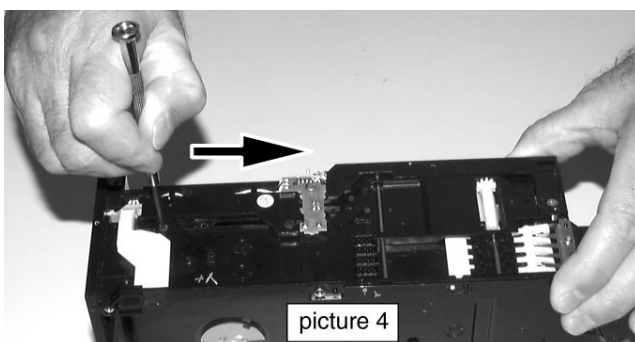

picture 4

Release snap as shown in picture 5 and pull tray out.

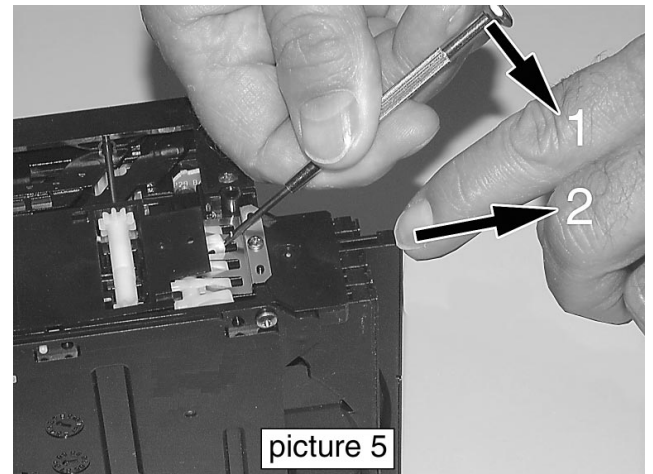

picture 5

To remove a CD from Play Position perform following steps:

1. Open tray 1 as described before.
2. Tear the tray out with speed (see picture 6). The tray can be inserted afterwards without any alignment.

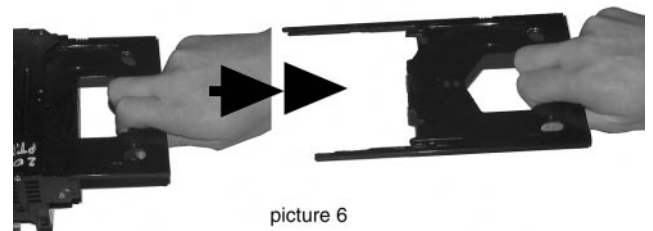

picture 6

3. Move lever (pos 29) forward to its endposition (see picture 4).
4. Push lever (pos 31) forward (see picture 7).

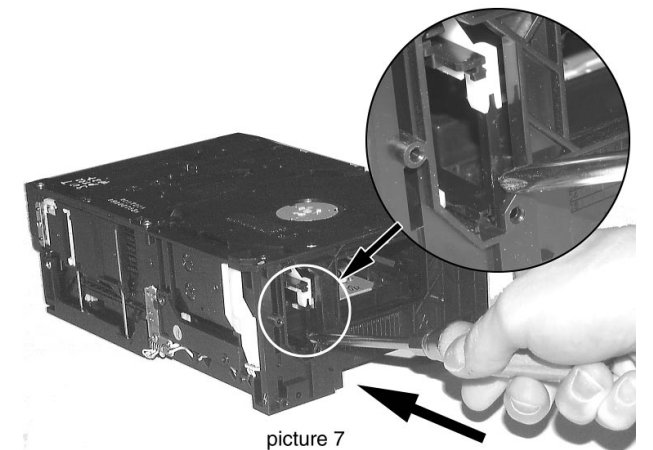

picture 7

5. Remove CD.

Location of switches

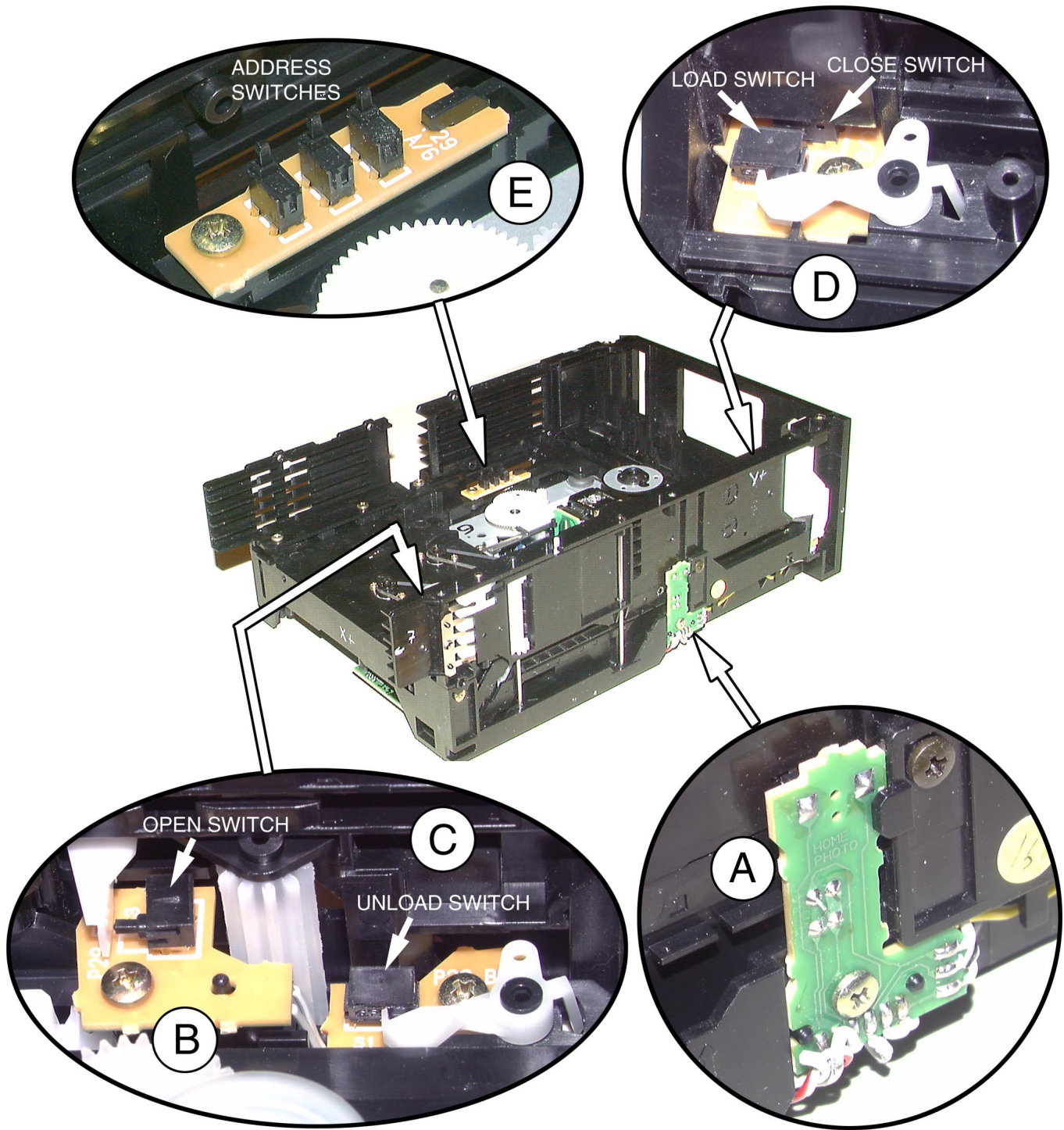

BLOCK DIAGRAM 5DTC MP3 Version

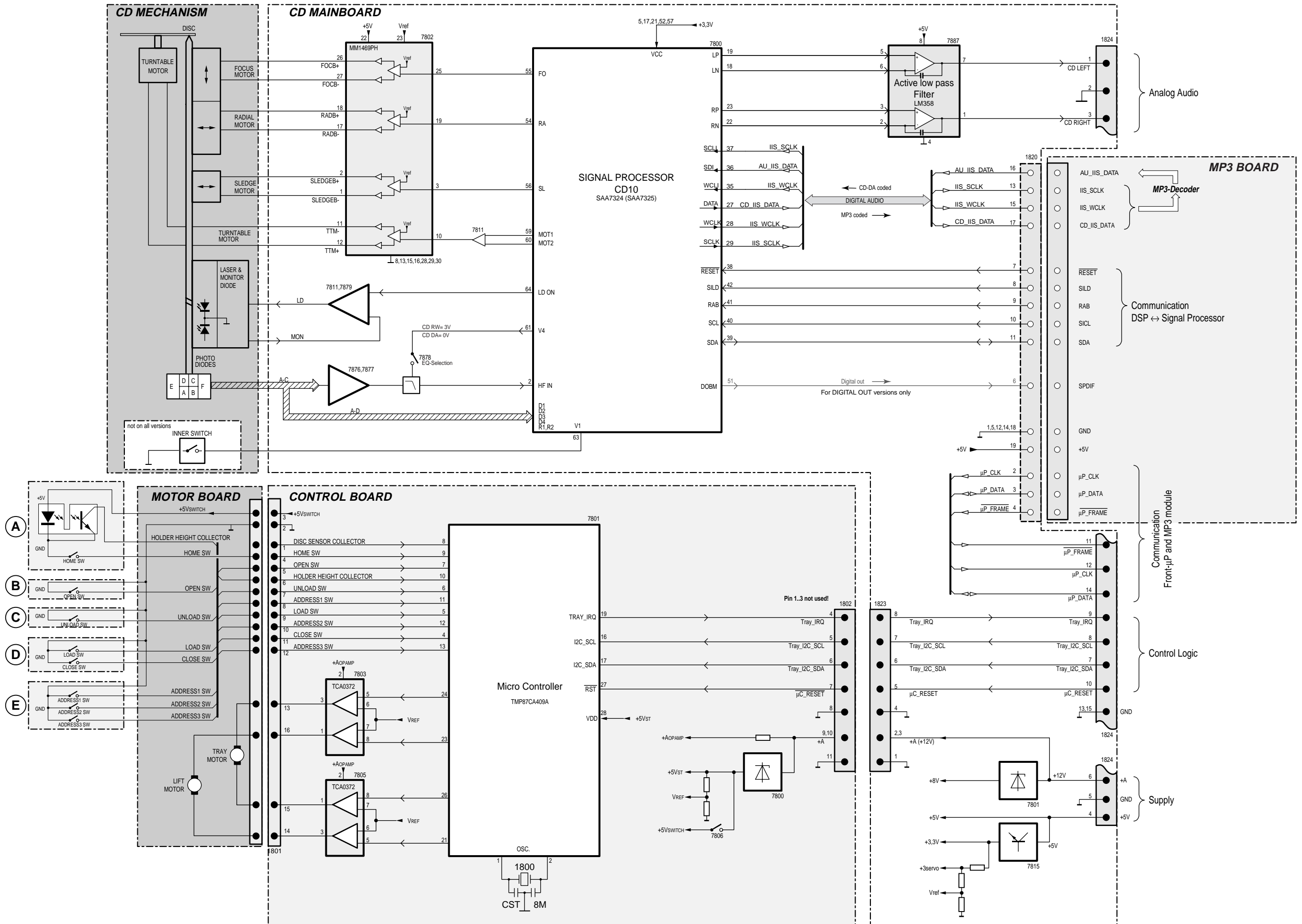

5DTC CD BOARD

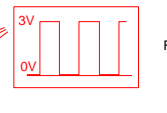
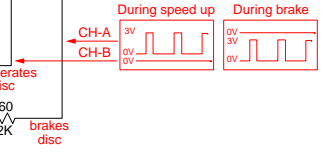
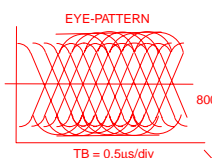
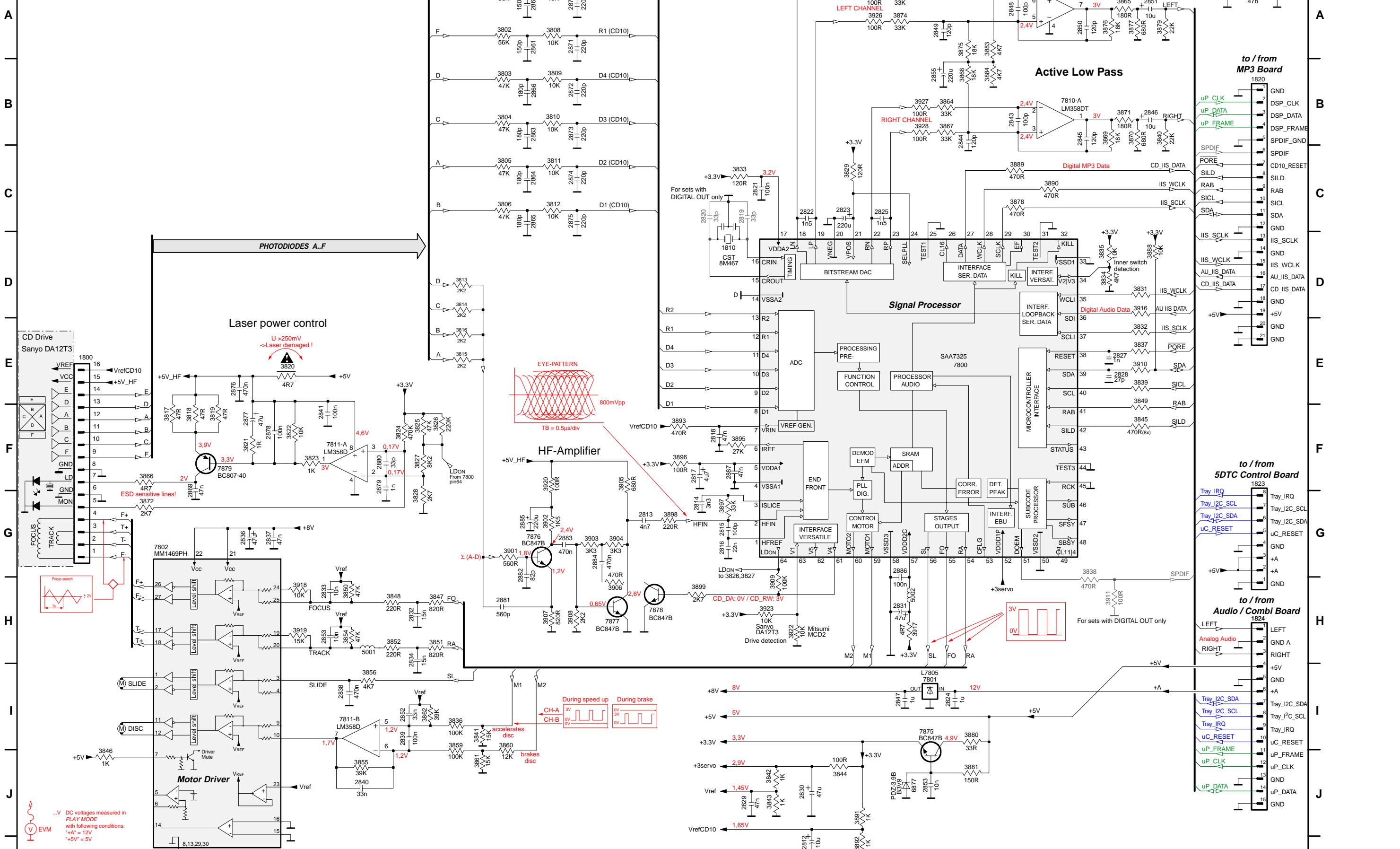

...V DC voltages measured in PLAY MODE with following conditions:
*+A = 12V
*+5V = 5V

MAPPING FOR
CIRCUIT DIAGRAM

1800	E1	3827	F5
1810	D9	3828	G5
1820	B15	3829	C10
1823	F15	3831	D14
1824	H15	3832	E14
2187	F9	3833	C9
2812	J10	3834	D13
2813	G8	3835	D13
2814	G9	3836	I6
2815	G9	3837	E14
2816	G9	3838	G13
2817	F9	3839	E14
2818	F9	3840	B14
2819	C9	3841	I6
2820	C9	3842	J9
2821	C9	3843	J9
2822	C10	3844	J10
2823	C10	3845	F14
2824	I12	3846	J1
2825	C11	3847	H5
2826	A15	3848	H5
2827	E13	3849	F14
2828	E13	3850	H4
2829	J9	3851	H5
2830	J10	3852	H5
2831	H11	3854	H4
2832	H5	3855	J4
2833	H4	3856	I5
2834	H5	3859	I6
2836	G3	3860	I6
2837	G3	3861	J6
2838	I4	3862	I5
2839	I5	3864	B11
2840	J4	3865	A14
2841	F4	3866	F2
2843	B12	3867	B11
2844	B12	3868	B12
2845	B13	3869	B13
2846	B14	3870	B14
2847	I11	3871	B14
2848	A12	3872	G2
2849	A11	3873	A11
2850	A13	3874	A11
2851	A14	3875	A12
2852	I5	3876	A13
2853	H4	3877	A14
2853	J11	3878	C12
2854	A12	3879	A14
2855	B11	3880	I12
2860	A6	3881	J12
2861	A6	3883	A12
2863	B6	3884	B12
2864	C6	3888	D14
2865	C6	3889	C12
2866	B6	3890	C13
2869	F2	3891	J10
2870	A7	3892	J10
2871	A7	3893	F8
2872	B7	3895	F9
2873	B7	3896	F8
2874	C7	3897	G9
2875	C7	3898	G8
2876	E3	3899	H8
2877	F3	3901	G6
2878	F3	3902	G7
2879	F5	3903	G7
2880	F5	3904	G8
2881	H6	3905	F8
2882	G6	3906	H8
2884	G7	3907	H7
2885	G6	3908	H7
2886	G11	3909	H9
2893	G7	3910	E14
3801	A6	3911	H13
3802	A6	3912	A11
3803	B6	3917	H11
3804	B6	3918	H4
3805	C6	3919	H4
3806	C6	3920	F7
3807	A7	3922	H10
3808	A7	3923	H9
3809	B7	3925	A11
3810	B7	3926	A11
3811	C7	3927	B11
3812	C7	3928	B11
3813	D6	5001	H5
3814	D6	5002	H11
3815	E6	6877	J11
3816	D14	7800	D11
3816	E6	7801	I11
3817	F2	7802	G2
3818	F2	7810-A	B13
3819	F3	7810-B	A13
3820	E4	7811-A	F4
3821	F3	7811-B	I4
3822	F4	7875	I11
3823	F4	7876	G7
3824	F5	7877	H8
3825	F5	7878	H8
3826	F5	7879	F3

MAPPING FOR
COMPONENT LAYOUT

1800	D3	3851	C5
1810	E5	3852	B3
1823	D7	3853	B6
1824	A5	3854	B2
2811	B6	3857	C1
2812	C3	3865	A4
2813	C4	3866	D3
2817	C3	3868	A4
2819	E5	3869	B5
2820	E5	3870	A5
2823	E6	3871	B5
2824	B1	3872	E3
2826	B5	3875	A4
2827	C6	3876	B4
2828	C6	3877	A5
2829	C2	3878	D6
2830	B5	3879	A5
2831	B5	3883	A4
2833	B2	3884	A4
2834	C5	3887	B6
2835	B3	3888	C6
2836	A2	3889	E6
2837	A2	3890	E6
2841	E2	3891	C3
2843	B4	3892	C3
2844	B4	3893	C3
2845	B4	3894	C3
2846	A5	3895	D4
2847	B1	3896	C3
2850	B4	3899	C4
2851	A5	3901	C4
2854	B4	3903	C4
2855	A4	3904	C4
2857	E2	3905	B3
2860	C3	3906	C4
2861	D4	3907	D4
2863	D3	3908	C4
2864	D3	3909	C4
2865	D4	3910	C6
2869	D4	3912	A4
2870	E5	3916	C6
2871	E5	3917	B5
2872	E4	3918	A2
2873	E4	3919	B2
2874	D4	3922	C4
2875	E4	3923	B4
2877	D3	4804	A4
2878	D2	4807	A4
2879	E2	4809	C7
2880	E2	4810	C7
2881	D4	4811	C6
2882	C4	4814	C6
2883	C4	4820	C2
2884	C4	4821	C2
2885	B5	4822	C2
2887	D4	4824	C2
2888	A1	4835	D2
3801	C3	4836	A5
3802	D4	4837	B5
3803	C4	4838	C6
3804	D3	4840	A2
3805	C3	4841	B6
3806	D4	4843	D2
3807	E4	5001	B3
3808	E4	7800	C6
3809	E4	7801	B2
3810	E4	7802	B2
3811	E4	7810	B4
3812	D4	7811	D2
3813	C4	7876	C4
3814	D3	7877	C4
3815	D3	7878	C4
3816	D4	7879	E4

5DTC CD Board Side A

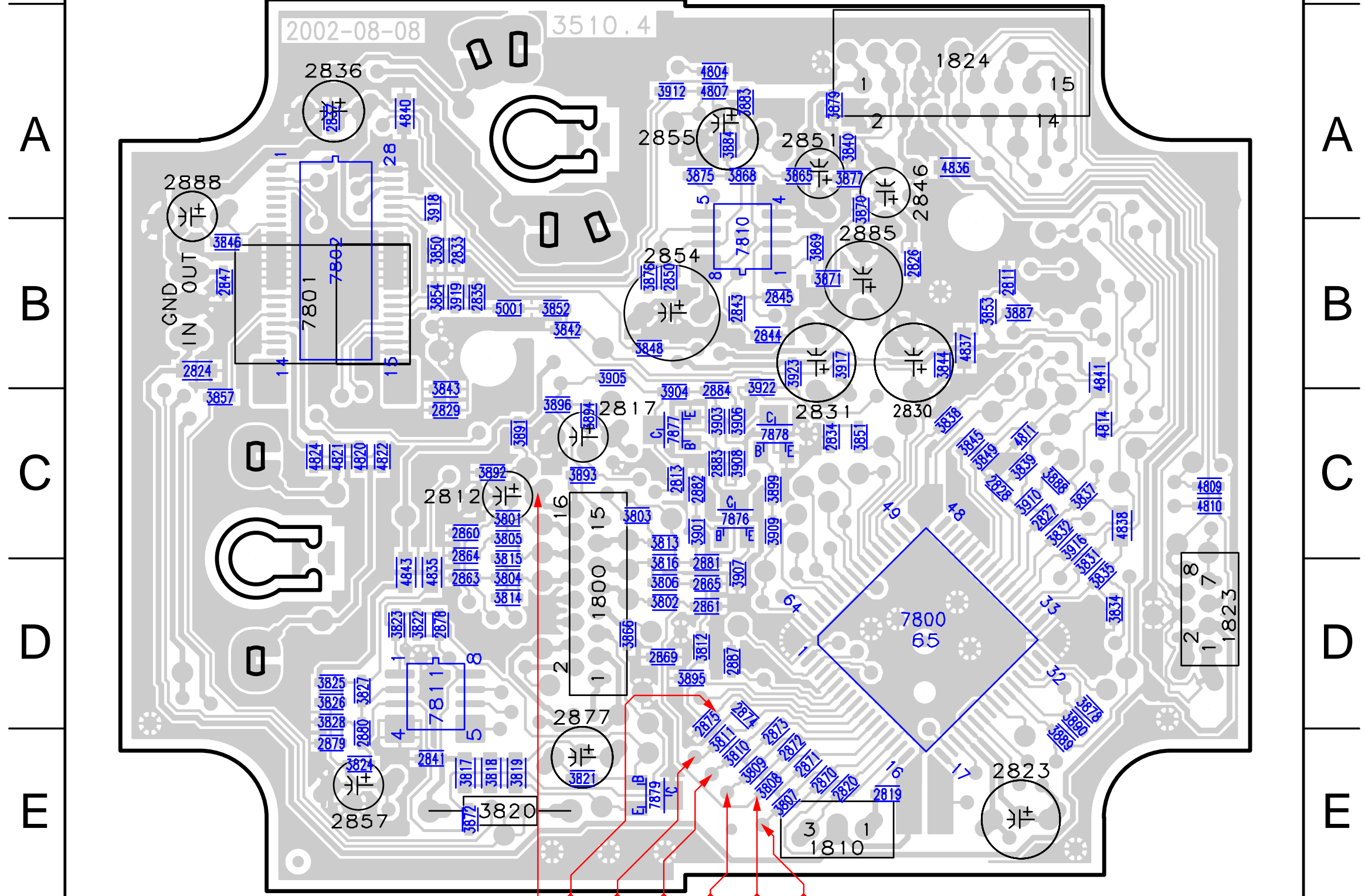

This assembly drawing shows a summary of all possible versions. For components used in a specific version see schematic diagram respectively partslist.

5DTC CD Board Side B

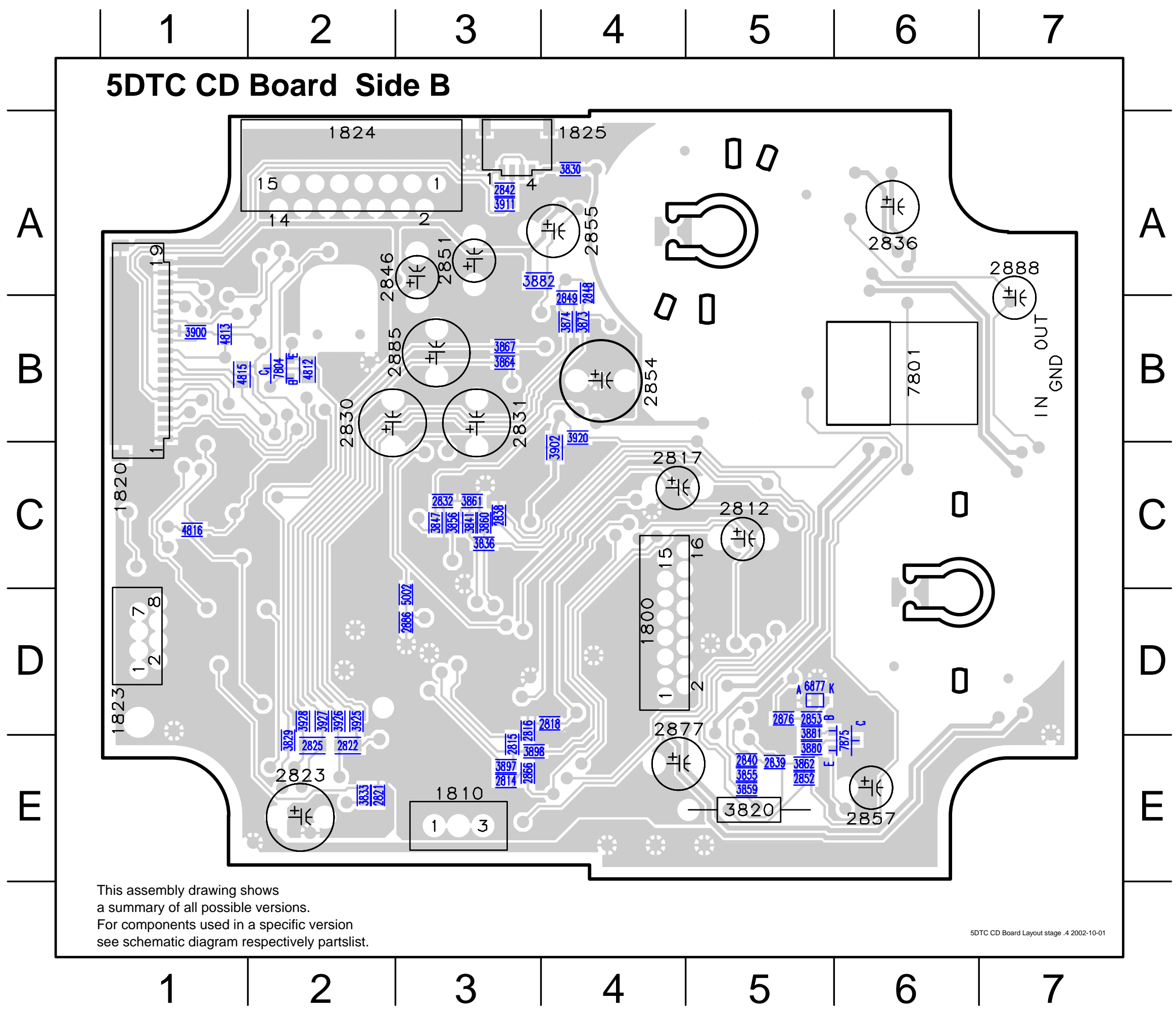

- 1800 D5
- 1810 E3
- 1820 C1
- 1823 D1
- 1824 A3
- 1825 A4
- 2812 C5
- 2814 E4
- 2815 E4
- 2816 D4
- 2817 C5
- 2818 D4
- 2821 E3
- 2822 E3
- 2823 E2
- 2825 E2
- 2830 B2
- 2831 B4
- 2832 C3
- 2836 A6
- 2838 C4
- 2839 E5
- 2840 E5
- 2842 A4
- 2846 A3
- 2848 A4
- 2849 B4
- 2851 A3
- 2852 E6
- 2853 D6
- 2854 B5
- 2855 A4
- 2857 E6
- 2866 E4
- 2876 D5
- 2877 D5
- 2885 B3
- 2886 D3
- 2888 A7
- 3820 E5
- 3829 E2
- 3830 A4
- 3833 E3
- 3836 C3
- 3841 C3
- 3847 C3
- 3855 E5
- 3856 C3
- 3859 E5
- 3860 C3
- 3861 C3
- 3862 E6
- 3864 B4
- 3867 B4
- 3873 B4
- 3874 B4
- 3880 E6
- 3881 D6
- 3882 A4
- 3897 E4
- 3898 E4
- 3900 B1
- 3902 C4
- 3911 A4
- 3920 B4
- 3925 D3
- 3926 D2
- 3927 D2
- 3928 D2
- 4812 B2
- 4813 B2
- 4815 B2
- 4816 C1
- 5002 D3
- 6877 D6
- 7801 B6
- 7804 B2
- 7875 E6

This assembly drawing shows a summary of all possible versions. For components used in a specific version see schematic diagram respectively partslist.

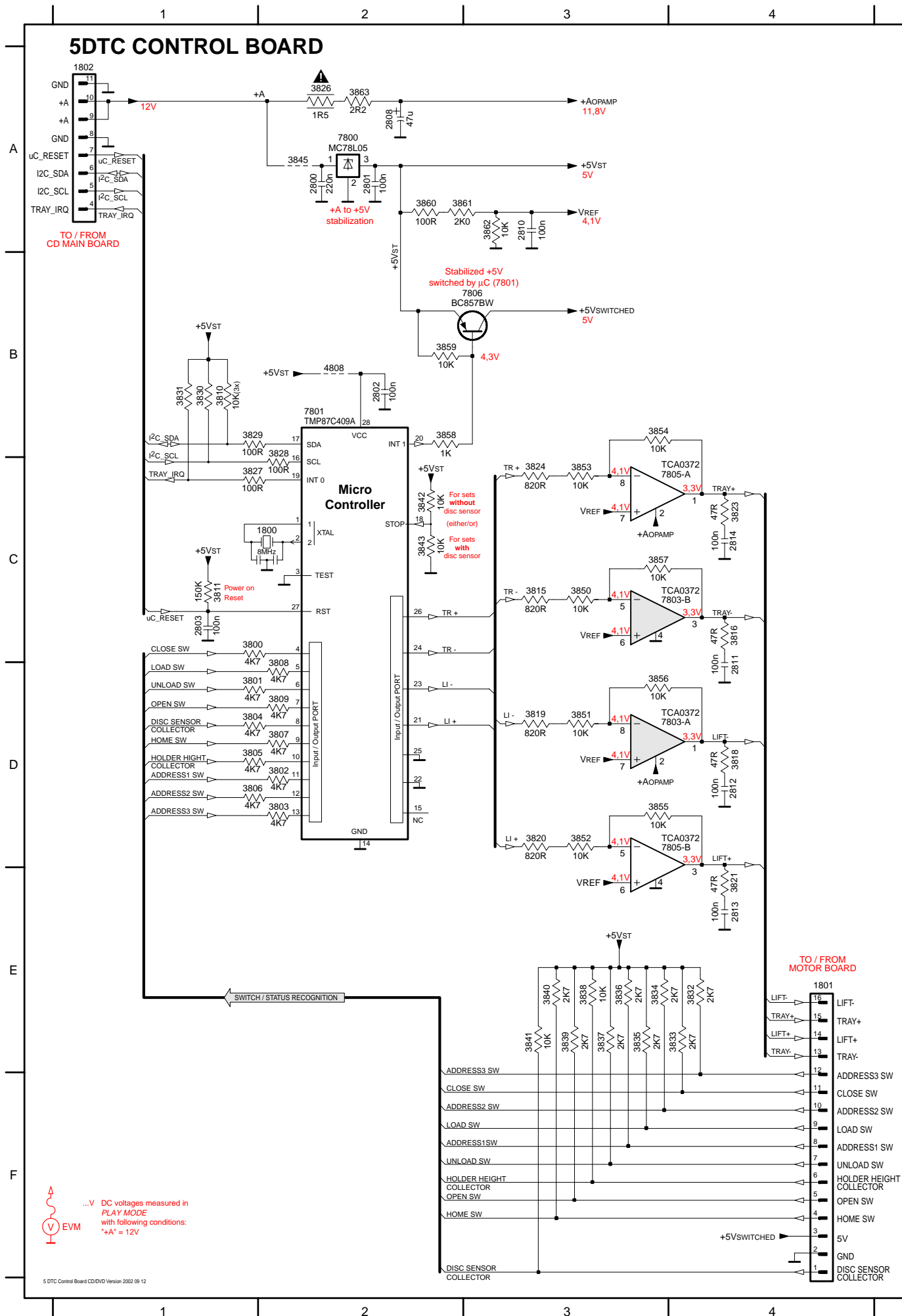

MAPPING FOR CIRCUIT DIAGRAM

1800	C2	2810	A3	3804	D1	3811	C1	3824	C3	3833	E4	3841	E3	3854	B3	3862	A3	7805-B	D3
1801	E4	2811	D4	3805	D1	3815	C3	3826	A2	3834	E3	3842	C2	3855	D3	3863	A2	7806	B3
1802	A1	2812	D4	3806	D1	3816	C4	3827	C1	3835	E3	3843	C2	3856	D3	3868	B2		
2800	A2	2813	E4	3807	D2	3818	D4	3828	C2	3836	E3	3845	A2	3857	C3	3869	A2		
2801	A2	2814	C4	3808	D1	3819	D3	3829	B1	3837	E3	3850	C3	3858	B2	7801	B2		
2802	B2	3800	C1	3808	D2	3820	D3	3830	B1	3838	E3	3851	D3	3859	B3	7803-A	D3		
2803	C1	3802	D2	3809	D2	3821	E4	3831	B1	3839	E3	3852	D3	3860	A2	7803-B	C3		
2808	A2	3803	D2	3810	B1	3823	C4	3832	E4	3840	E3	3853	C3	3861	A2	7805-A	C3		

MAPPING FOR COMPONENT LAYOUT

1800	B2	2810	A5	3806	C4	3819	A4	3832	C4	3843	A2	3857	A5	4804	A2	4816	D2	7803	A5
1801	C4	2811	A5	3807	C3	3820	A4	3833	B2	3845	D2	3858	B5	4805	C1	4817	A6	7804	B2
1802	C2	2812	A6	3808	B2	3821	B5	3834	C4	3847	B1	3859	C5	4806	A2	4818	C5	7806	C5
2800	D2	2813	B5	3809	C3	3823	B6	3835	C2	3848	B1	3860	C5	4807	C1	4819	A6	9801	C5
2801	D2	2814	B6	3810	C2	3824	A4	3836	C4	3850	A4	3861	B5	4808	C2	4820	B5	9802	B2
2802	A2	3800	B2	3811	A2	3826	B6	3837	C3	3851	A4	3862	A5	4809	C5	4821	C3	9804	A5
2803	B1	3801	C3	3812	A1	3827	B2	3838	C4	3852	A4	3863	B6	4810	B2	4822	C3		
2804	C2	3802	C4	3813	B2	3828	C2	3839	C3	3853	A4	4800	C2	4811	C1	6801	B1		
2805	C1	3803	C4	3815	A4	3829	B2	3840	C4	3854	B5	4801	C2	4812	B2	7800	D2		
2808	A6	3804	C3	3816	A5	3829	C2	3841	C3	3855	B5	4802	C2	4813	B6	7801	B4		
2809	C2	3805	C4	3818	A6	3831	C1	3842	A2	3856	A6	4803	D1	4814	A4	7802	A2		

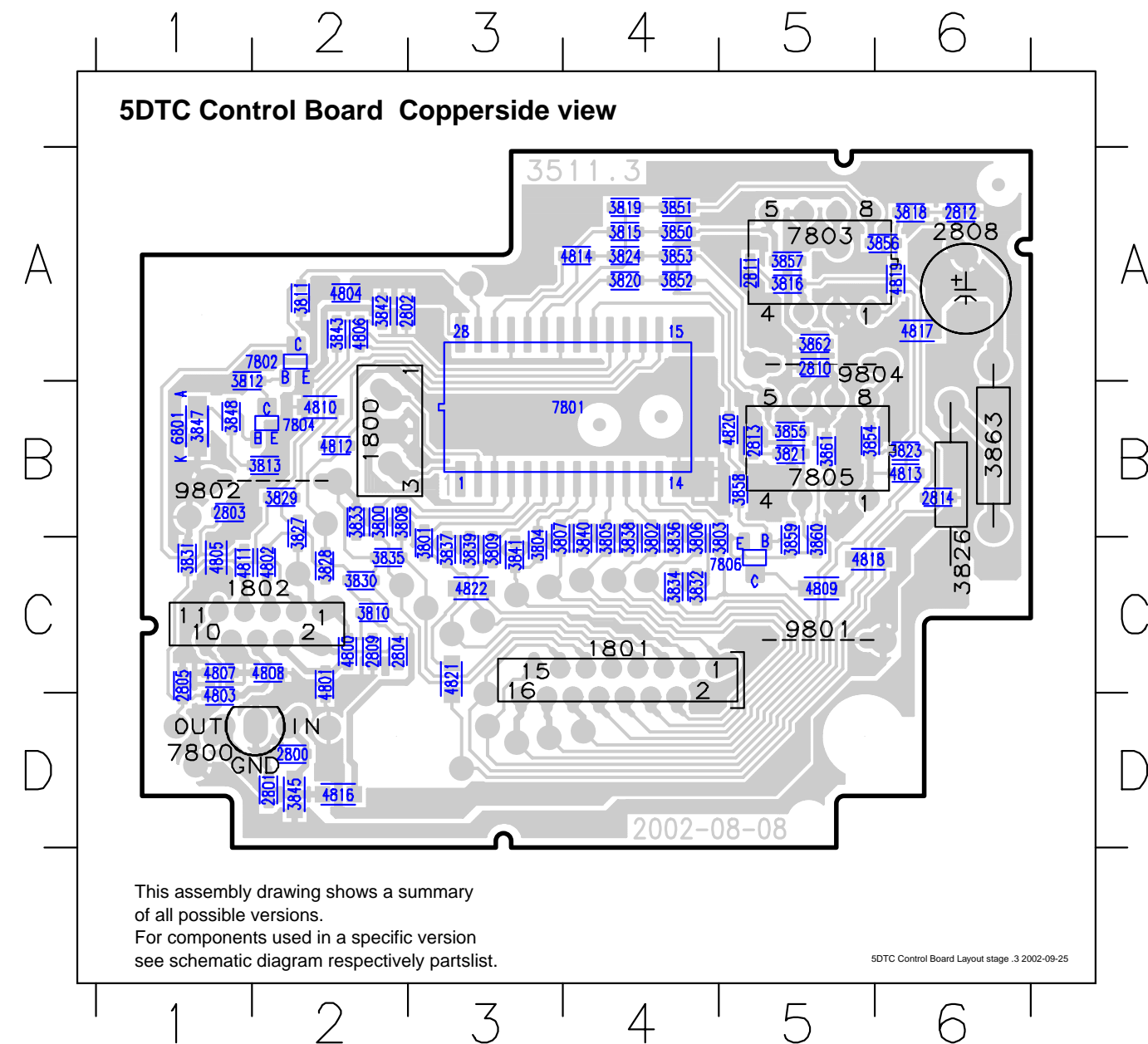

This assembly drawing shows a summary of all possible versions. For components used in a specific version see schematic diagram respectively partslist.

MP3 BOARD - CIRCUIT DIAGRAM

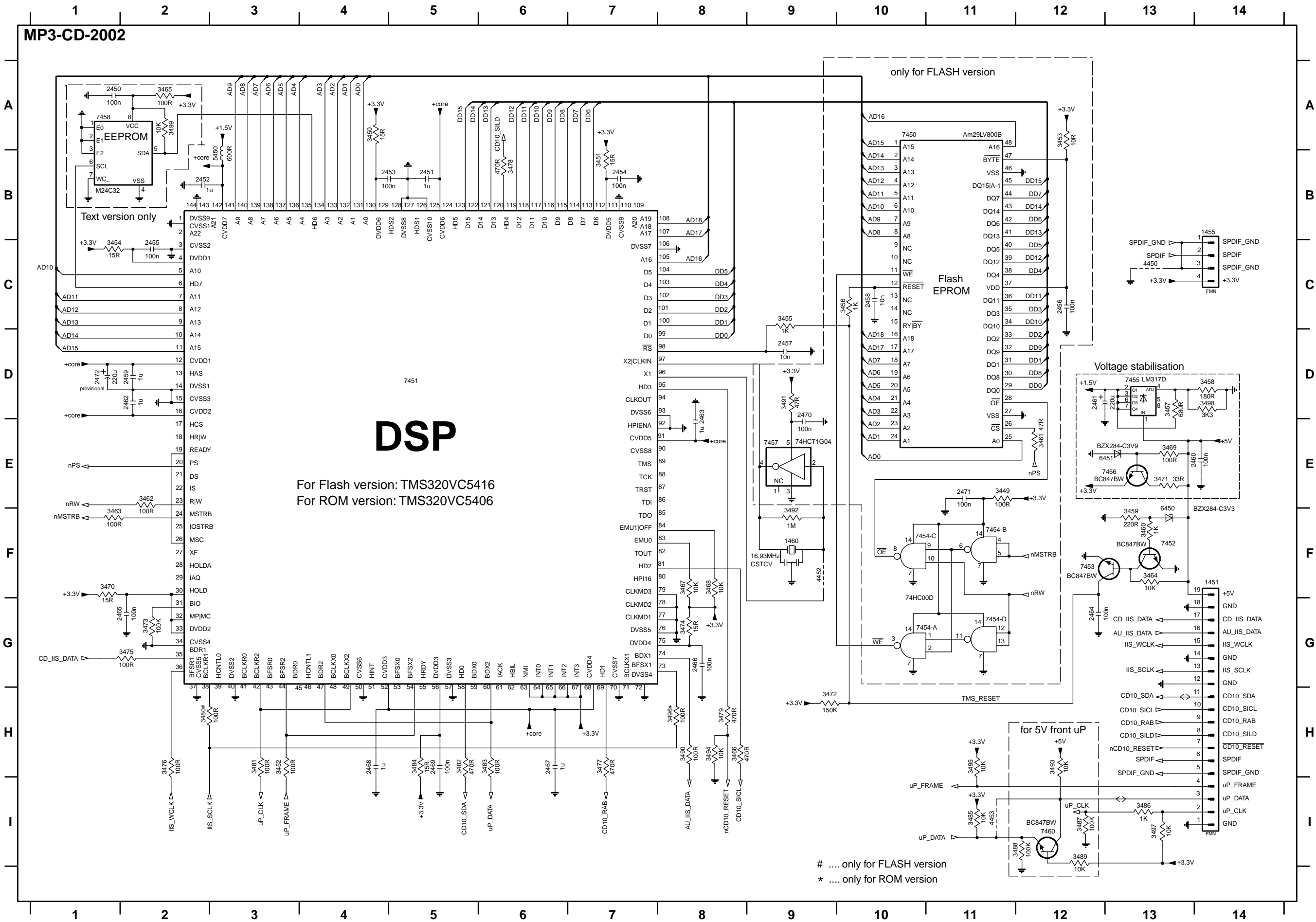

- 2451 B5
- 2452 B2
- 2453 B4
- 2454 B7
- 2455 C2
- 2456 C12
- 2457 D9
- 2458 C10
- 2459 D2
- 2460 E13
- 2461 D12
- 2462 D2
- 2463 D8
- 2464 G12
- 2465 G2
- 2466 G8
- 2467 H6
- 2468 H4
- 2469 H5
- 2470 D9
- 2471 E11
- 2472 D1
- 2473 E11
- 2474 D1
- 2475 A4
- 2476 B7
- 2477 H3
- 2478 A12
- 2479 C1
- 2480 C9
- 2481 C10
- 2482 D13
- 2483 D14
- 2484 F13
- 2485 E13
- 2486 E12
- 2487 E2
- 2488 F1
- 2489 F13
- 2490 A2
- 2491 H8
- 2492 F8
- 2493 F8
- 2494 E13
- 2495 F1
- 2496 E13
- 2497 H9
- 2498 G2
- 2499 G2
- 2500 G2
- 2501 H2
- 2502 H7
- 2503 B6
- 2504 H8
- 2505 H2
- 2506 H3
- 2507 H5
- 2508 H6
- 2509 H5
- 2510 I11
- 2511 H3
- 2512 H2
- 2513 H2
- 2514 H2
- 2515 H2
- 2516 H2
- 2517 H2
- 2518 H2
- 2519 H2
- 2520 H2
- 2521 H2
- 2522 H2
- 2523 H2
- 2524 H2
- 2525 H2
- 2526 H2
- 2527 H2
- 2528 H2
- 2529 H2
- 2530 H2
- 2531 H2
- 2532 H2
- 2533 H2
- 2534 H2
- 2535 H2
- 2536 H2
- 2537 H2
- 2538 H2
- 2539 H2
- 2540 H2
- 2541 H2
- 2542 H2
- 2543 H2
- 2544 H2
- 2545 H2
- 2546 H2
- 2547 H2
- 2548 H2
- 2549 H2
- 2550 H2

.... only for FLASH version
 * only for ROM version

MP3 BOARD - COMPONENT LAYOUT

1460 A3	3449 C3	3460 C2	3482 B2	3492 A3	6450 C2
2456 A4	3452 B2	3461 B5	3483 B2	3493 B2	7450 B4
2458 D4	3453 A4	3462 C3	3485 B2	3495 B2	7452 C2
2459 D4	3455 B5	3463 C3	3486 A2	3497 B2	7453 C2
2460 D2	3456 D4	3464 C2	3487 A2	3498 D3	7454 C3
2462 C4	3457 D3	3466 A3	3488 B3	4452 A3	7455 D2
2470 B4	3458 D3	3472 D2	3489 B3	4453 B2	7457 B4
2471 C3	3459 C2	3478 B2	3491 B4	5450 D3	7460 B2

1451 B5	2457 A2	2469 B4	3469 C4	3479 A2	4450 A4
1455 A4	2461 D4	2472 D3	3470 D3	3480 C4	6451 D4
2450 C1	2463 A3	3450 C1	3471 C4	3481 C4	7451 B3
2451 B1	2464 D4	3451 B1	3473 C4	3484 B4	7456 D4
2452 C2	2465 D4	3454 D2	3474 A3	3490 A4	7458 D1
2453 B1	2466 A3	3465 C1	3475 C4	3494 A2	
2454 B1	2467 B4	3467 A3	3476 C4	3496 A4	
2455 D2	2468 B4	3468 A3	3477 B4	3499 C1	

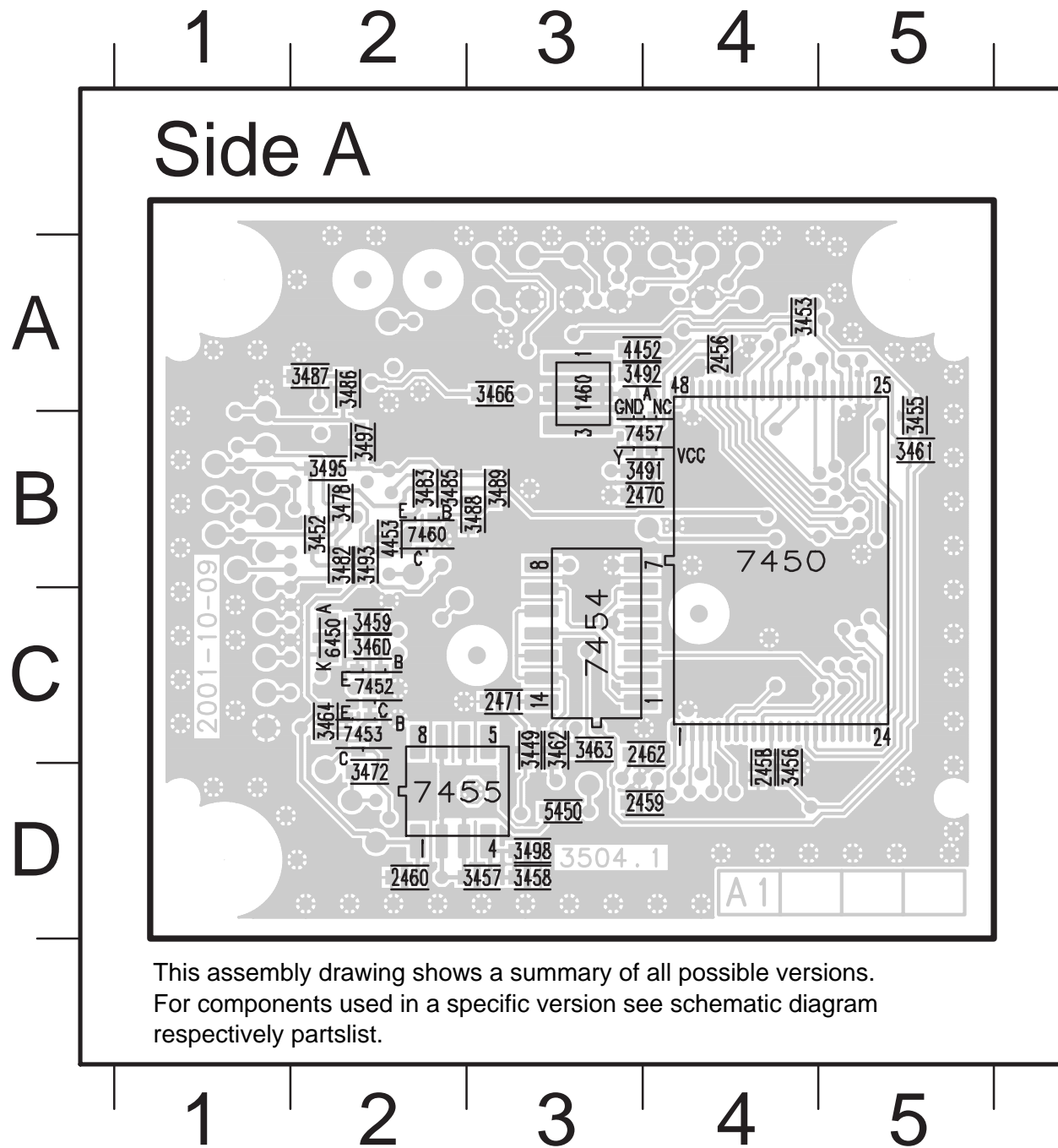

This assembly drawing shows a summary of all possible versions.
For components used in a specific version see schematic diagram
respectively partslist.

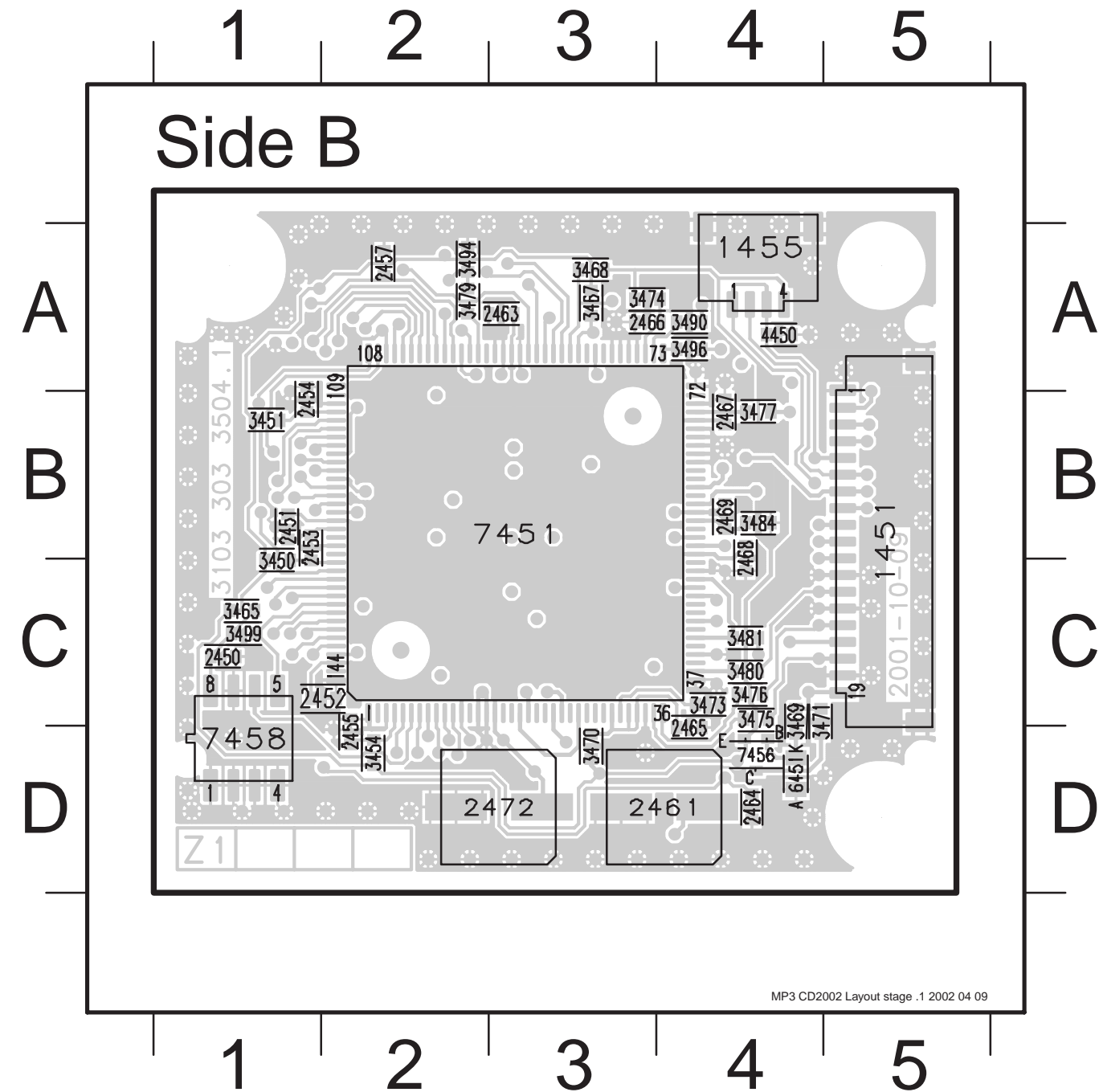

Exploded view 5DTC mechanic - for orientation only

Sketch-1

TRAY(SUB)	3	83	84	85	86
TRAY No.	TRAY 1	TRAY 2; TRAY 3	TRAY 4	TRAY 5	
Part A	1	HOLE	1	HOLE	1
Part B	2	2	HOLE	HOLE	2
Part C	3	3	3	3	HOLE

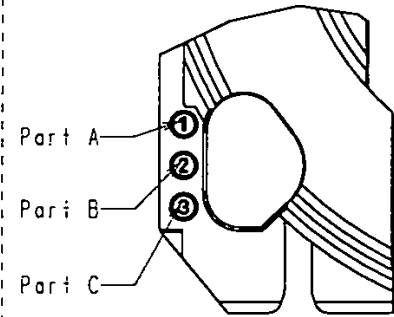

Sketch-2

TRAY(MAIN)

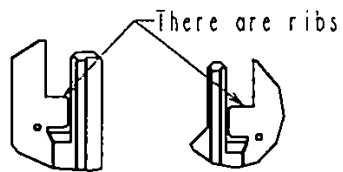

2 TRAY 1~4

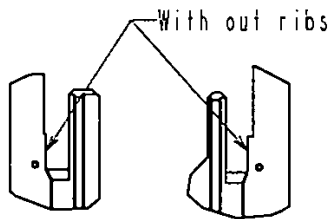

87 TRAY 5

See sketch-1

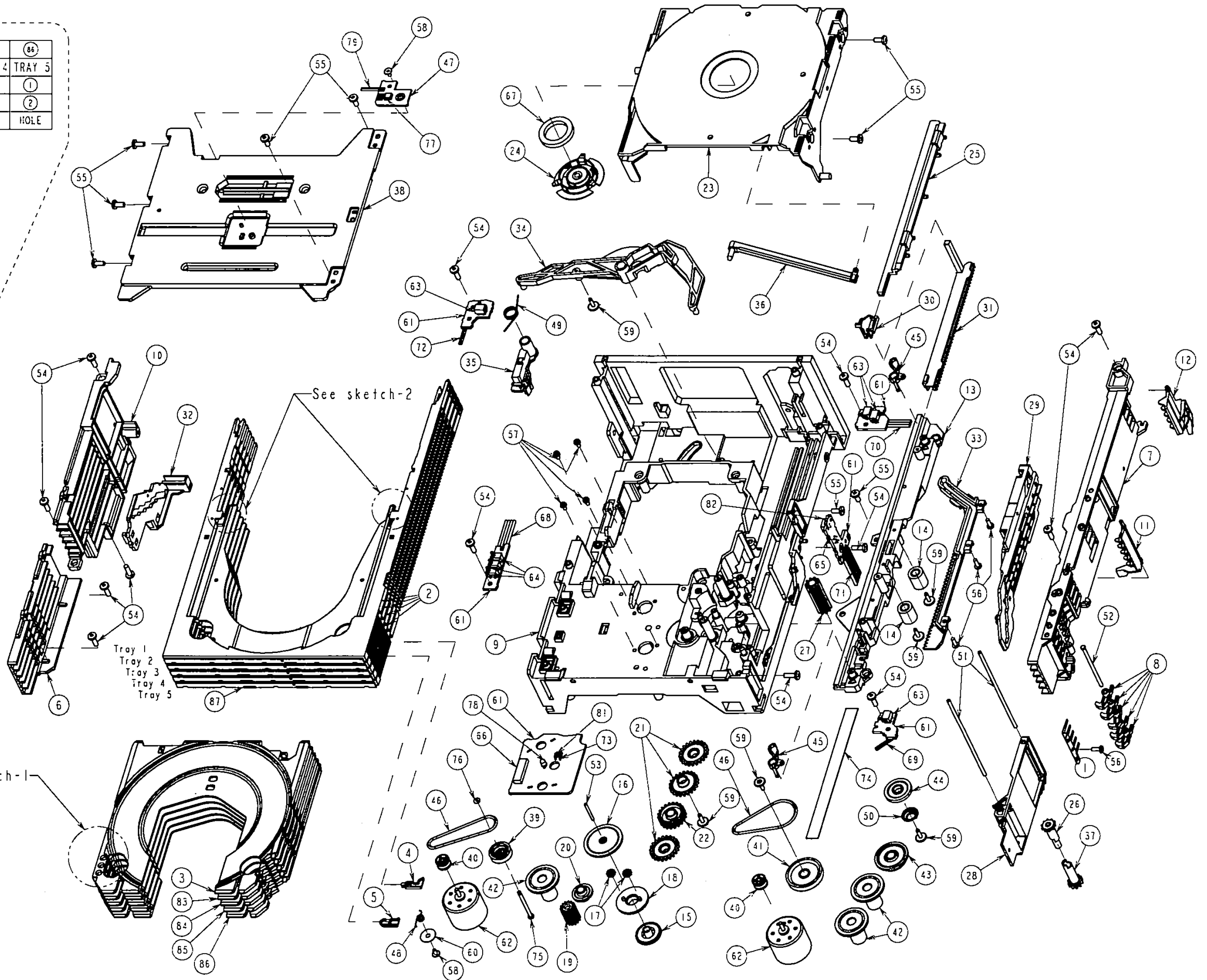

ELECTRICAL PARTSLIST 5DTC MODULE MP3CD Version CD Board**MECHANICAL PARTS**

	3103 308 54710	5DTC Module (mechanic w/o electronic)
201	3103 309 05390	CD DRIVE DA12T3
252	4822 529 10387	Rubber damper CD DRIVE, FRONT
253	4822 529 10386	Rubber damper CD DRIVE, REAR

MISCELLANEOUS

	3103 308 67020	MP3 Board
1800	4822 267 11028	FFC-CONNECTOR 16P, Side entry
1820	2422 025 17303	FFC-CONNECTOR 19P, Side entry
1823	2422 025 16371	FFC-CONNECTOR 8P, Side entry
1824	4822 265 10979	FFC-CONNECTOR, 15P, Side entry

8001	3103 308 93090	FFC CABLE 16Pin 80mm BD
8051	3103 308 93100	FFC-CABLE 19Pin 90mm AD
8052	3103 308 93120	FFC CABLE 8Pin 80mm BD

CAPACITORS

2812	4822 124 11947	10µF	20%	16V
2813©	4822 126 13193	4,7nF	10%	63V
2814©	5322 126 11579	3,3nF	10%	63V
2815©	2020 552 94427	100pF	5%	50V
2816©	3198 017 42230	22nF	10%	50V

2817	4822 124 22726	4,7µF	20%	35V
2818©	3198 024 44730	47nF	5%	50V
2821©	2238 586 59812	100nF	10%	50V
2822©	4822 126 13344	1,5nF	5%	63V
2823	4822 124 42383	220µF	20%	4V

2824©	4822 126 14043	1µF	20%	16V
2825©	4822 126 13344	1,5nF	5%	63V
2826©	3198 017 34730	47nF	10%	16V
2827©	5322 126 11578	1nF	10%	63V
2828©	4822 126 11669	27pF	10%	50V

2829©	3198 017 34730	47nF	10%	16V
2830	4822 124 81286	47µF	20%	16V
2831	4822 124 81286	47µF	20%	16V
2832©	3198 017 31530	15nF	10%	50V
2833©	5322 126 11583	10nF	10%	63V

2834©	3198 017 31530	15nF	10%	50V
2835©	5322 126 11583	10nF	10%	63V
2836	4822 124 40433	47µF	20%	25V
2837©	3198 017 34730	47nF	10%	16V
2838©	3198 017 44740	470nF	20%	10V

2839©	2238 586 59812	100nF	10%	50V
2840©	4822 126 14549	33nF	10%	16V
2841©	2238 586 59812	100nF	10%	50V
2843©	2020 552 94427	100pF	5%	50V
2844©	5322 122 33861	120pF	5%	NP0

2845©	5322 122 33861	120pF	5%	NP0
2846	4822 124 40248	10µF	20%	63V
2847©	3198 017 41050	1µF	20%	10V
2848©	2020 552 94427	100pF	5%	50V
2849©	5322 122 33861	120pF	5%	NP0

2850©	5322 122 33861	120pF	5%	NP0
2851	4822 124 40248	10µF	20%	63V
2852©	4822 126 14549	33nF	10%	16V
2853©	5322 126 11583	10nF	10%	63V
2854	4822 124 12245	220µF	20%	16V

2855	4822 124 11912	220µF	20%	6,3V
2860©	4822 122 33753	150pF	5%	50V
2861©	4822 122 33753	150pF	5%	50V
2863©	4822 126 14508	180pF	5%	50V
2864©	4822 126 14508	180pF	5%	50V

2865©	4822 126 14508	180pF	5%	50V
2866©	4822 126 14508	180pF	5%	50V

CAPACITORS

2869©	3198 017 34730	47nF	10%	16V
2870©	4822 126 13883	220pF	5%	50V
2871©	4822 126 13883	220pF	5%	50V
2872©	4822 126 13883	220pF	5%	50V
2873©	4822 126 13883	220pF	5%	50V

2874©	4822 126 13883	220pF	5%	50V
2875©	4822 126 13883	220pF	5%	50V
2876©	3198 017 44740	470nF	20%	10V
2877	4822 124 40433	47µF	20%	25V
2878©	2238 586 59812	100nF	10%	50V

2879©	5322 126 11578	1nF	10%	63V
2880©	2222 867 15339	33pF	5%	50V
2881©	4822 126 14249	560pF	10%	50V
2882©	4822 126 14226	82pF		50V
2883©	3198 017 44740	470nF	20%	10V

2884©	3198 017 44740	470nF	20%	10V
2885	4822 124 40196	220µF	20%	16V
2886©	2238 586 59812	100nF	10%	50V
2887©	3198 017 34730	47nF	10%	16V

RESISTORS

3801©	4822 051 30563	56kΩ	5%	0,06W
3802©	4822 051 30563	56kΩ	5%	0,06W
3803©	4822 117 12925	47kΩ	1%	0,06W
3804©	4822 117 12925	47kΩ	1%	0,06W
3805©	4822 117 12925	47kΩ	1%	0,06W

3806©	4822 117 12925	47kΩ	1%	0,06W
3807©	4822 051 30103	10kΩ	5%	0,06W
3808©	4822 051 30103	10kΩ	5%	0,06W
3809©	4822 051 30103	10kΩ	5%	0,06W
3810©	4822 051 30103	10kΩ	5%	0,06W

3811©	4822 051 30103	10kΩ	5%	0,06W
3812©	4822 051 30103	10kΩ	5%	0,06W
3813©	4822 051 30222	2,2kΩ	5%	0,06W
3814©	4822 051 30222	2,2kΩ	5%	0,06W
3815©	4822 051 30222	2,2kΩ	5%	0,06W

3816©	4822 051 30222	2,2kΩ	5%	0,06W
3817©	4822 051 30479	47Ω	5%	0,06W
3818©	4822 051 30479	47Ω	5%	0,06W
3819©	4822 051 30479	47Ω	5%	0,06W
3820▲	4822 052 10478	4,7Ω	5%	NFR25

3821©	4822 117 12917	1Ω	5%	0,06W
3822©	4822 051 30103	10kΩ	5%	0,06W
3823©	4822 051 30102	1kΩ	5%	0,06W
3824©	4822 051 30474	470kΩ	5%	0,06W
3825©	5322 117 13029	47kΩ	1%	0,06W

3826©	4822 117 12891	220kΩ	1%	0,06W
3827©	5322 117 13056	8,2kΩ	1%	0,06W
3828©	5322 117 13052	2,7kΩ	1%	0,06W
3829©	4822 051 30121	120Ω	5%	0,06W
3831©	4822 051 30471	470Ω	5%	0,06W

3832©	4822 051 30471	470Ω	5%	0,06W
3833©	4822 051 30121	120Ω	5%	0,06W
3834©	4822 051 30472	4,7kΩ	5%	0,06W
3836©	4822 117 13632	100kΩ	1%	0,06W
3837©	4822 051 30471	470Ω	5%	0,06W

3839©	4822 051 30471	470Ω	5%	0,06W
3840©	4822 051 30223	22kΩ	5%	0,06W
3841©	4822 051 30153	15kΩ	5%	0,06W
3842©	4822 051 30102	1kΩ	5%	0,06W
3843©	4822 051 30102	1kΩ	5%	0,06W

3844©	4822 051 30101	100Ω	5%	0,06W
3845©	4822 051 30471	470Ω	5%	0,06W

ELECTRICAL PARTSLIST 5DTC MODULE MP3CD Version CD Board

RESISTORS

3846	4822 051 30102	1kΩ	5%	0,06W
3847	4822 117 12968	820Ω	5%	0,06W
3848	4822 051 30221	220Ω	5%	0,06W
3849	4822 051 30471	470Ω	5%	0,06W
3850	4822 117 12925	47kΩ	1%	0,06W
3851	4822 117 12968	820Ω	5%	0,06W
3852	4822 051 30221	220Ω	5%	0,06W
3854	4822 117 12925	47kΩ	1%	0,06W
3855	4822 051 30393	39kΩ	5%	0,06W
3856	4822 051 30472	4,7kΩ	5%	0,06W
3857	4822 051 30008	CHIP JUMPER 0603		
3859	4822 117 13632	100kΩ	1%	0,06W
3860	4822 051 30123	12kΩ	5%	0,06W
3861	4822 051 30153	15kΩ	5%	0,06W
3862	4822 051 30393	39kΩ	5%	0,06W
3864	4822 051 30333	33kΩ	5%	0,06W
3865	4822 051 30181	180Ω	5%	0,06W
3866	4822 117 13608	4,7Ω	5%	0,06W
3867	4822 051 30333	33kΩ	5%	0,06W
3868	4822 051 30183	18kΩ	5%	0,06W
3869	4822 051 30183	18kΩ	5%	0,06W
3870	4822 051 30681	680Ω	5%	0,06W
3871	4822 051 30181	180Ω	5%	0,06W
3872	4822 051 30272	2,7kΩ	5%	0,06W
3873	4822 051 30333	33kΩ	5%	0,06W
3874	4822 051 30333	33kΩ	5%	0,06W
3875	4822 051 30183	18kΩ	5%	0,06W
3876	4822 051 30183	18kΩ	5%	0,06W
3877	4822 051 30681	680Ω	5%	0,06W
3878	4822 051 30471	470Ω	5%	0,06W
3879	4822 051 30223	22kΩ	5%	0,06W
3880	4822 051 30339	33Ω	5%	0,06W
3881	4822 051 30151	150Ω	5%	0,06W
3883	4822 051 30472	4,7kΩ	5%	0,06W
3884	4822 051 30472	4,7kΩ	5%	0,06W
3888	4822 051 30103	10kΩ	5%	0,06W
3889	4822 051 30471	470Ω	5%	0,06W
3890	4822 051 30471	470Ω	5%	0,06W
3891	4822 051 30102	1kΩ	5%	0,06W
3892	4822 051 30102	1kΩ	5%	0,06W
3893	4822 051 30471	470Ω	5%	0,06W
3895	4822 051 30273	27kΩ	5%	0,06W
3896	4822 051 30101	100Ω	5%	0,06W
3897	4822 051 30333	33kΩ	5%	0,06W
3898	4822 051 30221	220Ω	5%	0,06W
3899	4822 051 30272	2,7kΩ	5%	0,06W
3901	4822 051 30561	560Ω	5%	0,06W
3902	4822 117 11139	1,5kΩ	1%	0,1W
3903	4822 051 30332	3,3kΩ	5%	0,06W
3904	4822 051 30332	3,3kΩ	5%	0,06W
3905	4822 051 30681	680Ω	5%	0,06W
3906	4822 051 30471	470Ω	5%	0,06W
3907	4822 117 12968	820Ω	5%	0,06W
3908	4822 051 30222	2,2kΩ	5%	0,06W
3909	4822 117 13632	100kΩ	1%	0,06W
3910	4822 051 30471	470Ω	5%	0,06W
3912	4822 051 30221	220Ω	5%	0,06W
3916	4822 051 30471	470Ω	5%	0,06W
3917	4822 117 13608	4,7Ω	5%	0,06W
3918	4822 051 30103	10kΩ	5%	0,06W
3919	4822 051 30153	15kΩ	5%	0,06W
3920	4822 051 30101	100Ω	5%	0,06W
3923	4822 051 30103	10kΩ	5%	0,06W

RESISTORS

3925	4822 051 30101	100Ω	5%	0,06W
3926	4822 051 30101	100Ω	5%	0,06W
3927	4822 051 30101	100Ω	5%	0,06W
3928	4822 051 30101	100Ω	5%	0,06W
4807	4822 051 30008	CHIP JUMPER 0603		
4809	4822 051 30008	CHIP JUMPER 0603		
4820	4822 051 30008	CHIP JUMPER 0603		
4824	4822 051 30008	CHIP JUMPER 0603		
4835	4822 051 20008	CHIP JUMPER 0805		
4836	4822 051 20008	CHIP JUMPER 0805		
4837	4822 051 20008	CHIP JUMPER 0805		
4838	4822 051 20008	CHIP JUMPER 0805		
4840	4822 051 20008	CHIP JUMPER 0805		
4841	4822 051 20008	CHIP JUMPER 0805		
4843	4822 051 20008	CHIP JUMPER 0805		

COILS

1810	2422 540 98519	RESONATOR 8,467MHz
5001	2422 549 44607	FERRITE BEAD
5002	2422 549 44607	FERRITE BEAD

DIODES

6877	9322 129 34685	BZX284-C3V9
------	----------------	-------------

TRANSISTORS

7875	5322 130 42755	BC847C
7876	5322 130 42755	BC847C
7877	5322 130 42755	BC847C
7878	5322 130 42755	BC847C
7879	5322 130 60123	BC807-40

INTEGRATED CIRCUITS

7800	9352 684 20557	SAA7325H/T/M2B, Signal Processor
7801	4822 209 72554	MC7808CT 8V Regulator
7802	9322 181 79668	MM1469PH Motor Driver
7810	5322 209 82941	LM358D, Dual Opamp
7811	5322 209 82941	LM358D, Dual Opamp

ELECTRICAL PARTSLIST 5DTC MODULE MP3CD Version Control Board**MECHANICAL PARTS**

3103 308 54710 5DTC Module (mechanic w/o electronic)

MISCELLANEOUS

1801 2422 025 17065 FFC-CONNECTOR 16P, top entry
 1802 2422 025 17788 FFC-CONNECTOR 8P, top entry
 8021 3103 308 93110 FFC-CABLE 16Pin 60mm AD

CAPACITORS

2800© 4822 126 13879 220nF 20% 16V
 2801© 2238 586 59812 100nF 10% 50V
 2802© 2238 586 59812 100nF 10% 50V
 2803© 2238 586 59812 100nF 10% 50V
 2808 4822 124 40433 47µF 20% 25V

2810© 3198 017 34730 47nF 10% 16V
 2811© 2238 586 59812 100nF 10% 50V
 2812© 2238 586 59812 100nF 10% 50V
 2813© 2238 586 59812 100nF 10% 50V
 2814© 2238 586 59812 100nF 10% 50V

RESISTORS

3800© 4822 051 30472 4,7kΩ 5% 0,06W
 3801© 4822 051 30472 4,7kΩ 5% 0,06W
 3802© 4822 051 30472 4,7kΩ 5% 0,06W
 3803© 4822 051 30472 4,7kΩ 5% 0,06W
 3804© 4822 051 30472 4,7kΩ 5% 0,06W

3805© 4822 051 30472 4,7kΩ 5% 0,06W
 3806© 4822 051 30472 4,7kΩ 5% 0,06W
 3807© 4822 051 30472 4,7kΩ 5% 0,06W
 3808© 4822 051 30472 4,7kΩ 5% 0,06W
 3809© 4822 051 30472 4,7kΩ 5% 0,06W

3810© 4822 051 30103 10kΩ 5% 0,06W
 3811© 4822 051 30154 150kΩ 5% 0,0625W
 3815© 5322 117 13057 820Ω 1% 0,06W
 3816© 4822 051 30479 47Ω 5% 0,06W
 3818© 4822 051 30479 47Ω 5% 0,06W

3819© 5322 117 13057 820Ω 1% 0,06W
 3820© 5322 117 13057 820Ω 1% 0,06W
 3821© 4822 051 30479 47Ω 5% 0,06W
 3823© 4822 051 30479 47Ω 5% 0,06W
 3824© 5322 117 13057 820Ω 1% 0,06W

3826▲ 4822 117 12148 1,5Ω 5% 0,33W
 3827© 4822 051 30101 100Ω 5% 0,06W
 3828© 4822 051 30101 100Ω 5% 0,06W
 3829© 4822 051 30101 100Ω 5% 0,06W
 3830© 4822 051 30103 10kΩ 5% 0,06W

3831© 4822 051 30103 10kΩ 5% 0,06W
 3832© 4822 051 30272 2,7kΩ 5% 0,06W
 3833© 4822 051 30272 2,7kΩ 5% 0,06W
 3834© 4822 051 30272 2,7kΩ 5% 0,06W
 3835© 4822 051 30272 2,7kΩ 5% 0,06W

3836© 4822 051 30272 2,7kΩ 5% 0,06W
 3837© 4822 051 30272 2,7kΩ 5% 0,06W
 3838© 4822 051 30103 10kΩ 5% 0,06W
 3839© 4822 051 30272 2,7kΩ 5% 0,06W
 3840© 4822 051 30272 2,7kΩ 5% 0,06W

3841© 4822 051 30103 10kΩ 5% 0,06W
 3842© 4822 051 30103 10kΩ 5% 0,06W
 3845© 4822 051 20159 15Ω 5% 0,1W
 3850© 4822 117 12706 10kΩ 1% 0,06W
 3851© 4822 117 12706 10kΩ 1% 0,06W

3852© 4822 117 12706 10kΩ 1% 0,06W
 3853© 4822 117 12706 10kΩ 1% 0,06W
 3854© 4822 117 12706 10kΩ 1% 0,06W

RESISTORS

3855© 4822 117 12706 10kΩ 1% 0,06W
 3856© 4822 117 12706 10kΩ 1% 0,06W
 3857© 4822 117 12706 10kΩ 1% 0,06W
 3858© 4822 051 30102 1kΩ 5% 0,06W
 3859© 4822 051 30103 10kΩ 5% 0,06W

3860© 5322 117 13017 100Ω 1% 0,06W
 3861© 2322 704 62002 2kΩ 1% 0,06W
 3862© 4822 117 12706 10kΩ 1% 0,06W
 3863 4822 053 10228 2,2Ω 5% 1W
 4800© 4822 051 30008 CHIP JUMPER 0603

4802© 4822 051 30008 CHIP JUMPER 0603
 4803© 4822 051 30008 CHIP JUMPER 0603
 4804© 4822 051 30008 CHIP JUMPER 0603
 4805© 4822 051 20008 CHIP JUMPER 0805
 4806© 4822 051 30008 CHIP JUMPER 0603

4807© 4822 051 30008 CHIP JUMPER 0603
 4808© 4822 051 30008 CHIP JUMPER 0603
 4809© 4822 051 20008 CHIP JUMPER 0805
 4810© 4822 051 20008 CHIP JUMPER 0805
 4811© 4822 051 30008 CHIP JUMPER 0603

4812© 4822 051 30008 CHIP JUMPER 0603
 4813© 4822 051 30008 CHIP JUMPER 0603
 4814© 4822 051 30008 CHIP JUMPER 0603
 4816© 4822 051 20008 CHIP JUMPER 0805
 4817© 4822 051 20008 CHIP JUMPER 0805

4818© 4822 051 20008 CHIP JUMPER 0805
 4819© 4822 051 30008 CHIP JUMPER 0603
 4820© 4822 051 30008 CHIP JUMPER 0603
 4821© 4822 051 20008 CHIP JUMPER 0805
 4822© 4822 051 20008 CHIP JUMPER 0805

COILS

1800 4822 242 72066 CERAMIC FILTER 8,0MHz

TRANSISTORS

7806© 3198 010 42320 BC857BW

INTEGRATED CIRCUITS

7800 4822 209 72042 MC78L05ACP, STABILIZER
 7801© 3103 307 01640 TMP87P809M Microcontroller
 7803 4822 209 62059 TCA0372DP1, 2-FOLD OP-AMP.
 7805 4822 209 62059 TCA0372DP1, 2-FOLD OP-AMP.

ELECTRICAL PARTSLIST 5DTC MODULE MP3CD Version MP3 Board**MISCELLANEOUS**

1451 2422 025 17303 FFC-CONNECTOR 19P,side entry

CAPACITORS

2450	2238 586 59812	100nF	10%	50V
2451	3198 017 41050	1μF	20%	10V
2452	3198 017 41050	1μF	20%	10V
2453	2238 586 59812	100nF	10%	50V
2454	2238 586 59812	100nF	10%	50V

2455	2238 586 59812	100nF	10%	50V
2456	2238 586 59812	100nF	10%	50V
2457	5322 126 11583	10nF	10%	63V
2458	5322 126 11583	10nF	10%	63V
2459	3198 017 41050	1μF	20%	10V

2460	2238 586 59812	100nF	10%	50V
2461	4822 124 81059	220μF	20%	4V
2462	3198 017 41050	1μF	20%	10V
2463	3198 017 41050	1μF	20%	10V
2464	2238 586 59812	100nF	10%	50V

2465	2238 586 59812	100nF	10%	50V
2466	2238 586 59812	100nF	10%	50V
2467	3198 017 41050	1μF	20%	10V
2468	3198 017 41050	1μF	20%	10V
2469	2238 586 59812	100nF	10%	50V

2470	2238 586 59812	100nF	10%	50V
2471	2238 586 59812	100nF	10%	50V

RESISTORS

3449	4822 051 30101	100Ω	5%	0,06W
3450	4822 117 12971	15Ω	5%	0,06W
3451	4822 117 12971	15Ω	5%	0,06W
3452	4822 051 30101	100Ω	5%	0,06W
3453	4822 051 30109	10Ω	5%	0,06W

3454	4822 117 12971	15Ω	5%	0,06W
3455	4822 051 30102	1kΩ	5%	0,06W
3456	4822 051 30102	1kΩ	5%	0,06W
3457	5322 117 13051	680Ω	1%	0,06W
3458	5322 117 13061	180Ω	1%	0,06W

3459	4822 051 30221	220Ω	5%	0,06W
3460	4822 051 30102	1kΩ	5%	0,06W
3461	4822 051 30479	47Ω	5%	0,06W
3462	4822 051 30101	100Ω	5%	0,06W
3463	4822 051 30101	100Ω	5%	0,06W

3464	4822 051 30103	10kΩ	5%	0,06W
3465	4822 051 30101	100Ω	5%	0,06W
3466	4822 051 30471	470Ω	5%	0,06W
3467	4822 051 30103	10kΩ	5%	0,06W
3468	4822 051 30103	10kΩ	5%	0,06W

3469	4822 051 30101	100Ω	5%	0,06W
3470	4822 117 12971	15Ω	5%	0,06W
3471	4822 051 30339	33Ω	5%	0,06W
3472	4822 051 30154	150kΩ	5%	0,06W
3473	4822 117 13632	100kΩ	1%	0,06W

3474	4822 117 12971	15Ω	5%	0,06W
3475	4822 051 30101	100Ω	5%	0,06W
3476	4822 051 30101	100Ω	5%	0,06W
3477	4822 051 30471	470Ω	5%	0,06W
3478	4822 051 30471	470Ω	5%	0,06W

3479	4822 051 30471	470Ω	5%	0,06W
3480	4822 051 30101	100Ω	5%	0,06W
3481	4822 051 30101	100Ω	5%	0,06W
3482	4822 051 30471	470Ω	5%	0,06W
3483	4822 051 30101	100Ω	5%	0,06W

RESISTORS

3484	4822 117 12971	15Ω	5%	0,06W
3486	4822 051 30101	100Ω	5%	0,06W
3488	4822 117 13632	100kΩ	1%	0,06W
3489	4822 051 30103	10kΩ	5%	0,06W
3490	4822 051 30101	100Ω	5%	0,06W

3491	4822 051 30479	47Ω	5%	0,06W
3492	4822 051 30105	1MΩ	5%	0,06W
3493	4822 051 30103	10kΩ	5%	0,06W
3494	4822 051 30103	10kΩ	5%	0,06W
3495	4822 051 30103	10kΩ	5%	0,06W

3497	4822 051 30103	10kΩ	5%	0,06W
3498	4822 051 30332	3,3kΩ	5%	0,06W
3499	4822 051 30103	10kΩ	5%	0,06W
4450	4822 051 30008			CHIP JUMPER 0603

COILS

1460	4822 242 10989	CER.RES. 16,9MHz
5450	4822 157 11074	100μH

DIODES

6450	4822 130 11411	BZX284-C3V3
6451	4822 130 11366	BZX284-C3V9
7454	4822 130 34174	BZX79-B4V7

TRANSISTORS

7452	3198 010 42310	BC847BW
7453	3198 010 42310	BC847BW
7456	3198 010 42310	BC847BW
7460	3198 010 42310	BC847BW

INTEGRATED CIRCUITS

7451	not available	please order complete MP3 Board
7455	4822 209 17108	LM317LD Voltage Regulator
7457	9352 456 50115	HC1G04, Inverter
7458	9322 130 41668	M24C64, EEPROM

3103 308 67020 MP3 Board

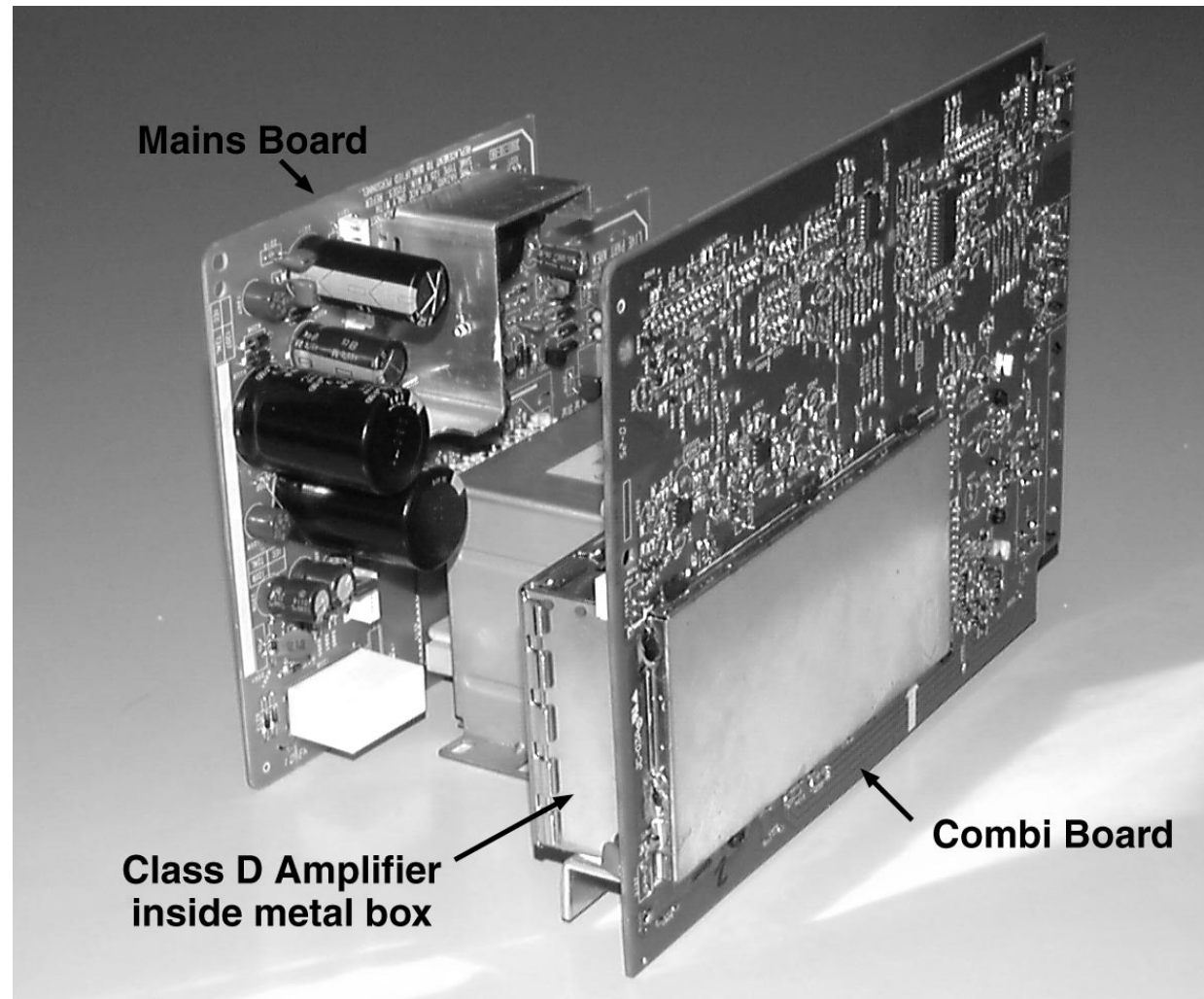

Class-D Circuit Description (BASED ON POWER 2003 MODULE 75-150W CLASS D)

Basically Class-D works by transforming the LF audio input to a square wave signal with a fixed frequency and a variable duty cycle. See simplified drawing below.

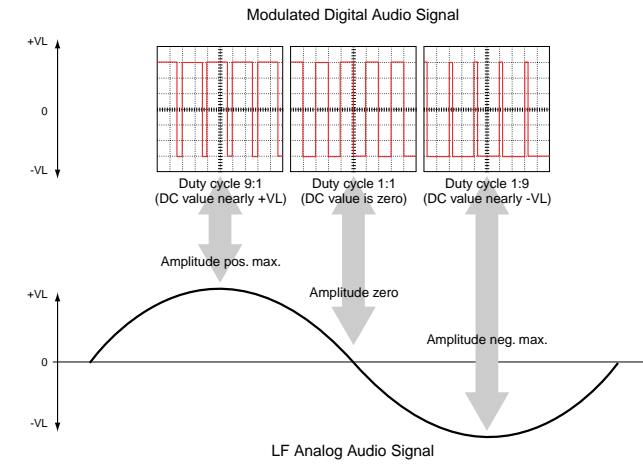

The amplitude of the square wave signal is equal to the supply voltage of the amplifier. With the audio signal the square wave signal is pulse-width modulated.

Compared to a conventional power amplifier the benefits of the Class D amplifier are:

- higher efficiency
- lower power dissipation
- smaller cooling fin
- smaller mains transformer

Disadvantage of this concept is:

- 500kHz square wave signal with high current requires a shielding box to suppress radiation.

Required Circuitries:

• 500kHz square wave oscillator.

The oscillator frequency is created by 7312-3; it is a dual-frequency oscillator with ceramic resonators 5300 and 5302, which resonate at 500kHz and 425kHz respectively. The resonators are switched by transistors 7309 and 7316, controlled by the "OZ_SW" line from the port expander 7406. The reason for 2 frequencies is to avoid tuner disturbances in the AM-band.

The oscillator signal is shaped to square wave with 7312-2, afterwards buffered and fed to the amplifier modulators (ROZ to the right channel, LOZ to the left). One channel gets inverted clock to balance supply loading.

• Modulator

The modulator forms the pulse width modulated signal. For each channel a separate modulation is required.

• Power FETs

The FETs require drivers which supply the gates. One for the high-side-FET and one for the low-side-FET. Because of the different supply voltages also an additional level shifter is necessary per driver.

• Output filter

The output filter is necessary to block the 500kHz square wave signal from the speaker. Refers to the left channel in schematic diagrams. It consists of a series-mode coil 5101 and a capacity of approx. 550nF (2116, 2134), which forms a Chebycheff filter with 40kHz cut-off frequency at 6Ω load. For EMC reasons both, the speaker output and the return ground are fed through a common mode coil (5102). The filter is further improved by splitting the output capacity into 2116 before and 2134 after the common mode coil.

Blockdiagram Class D

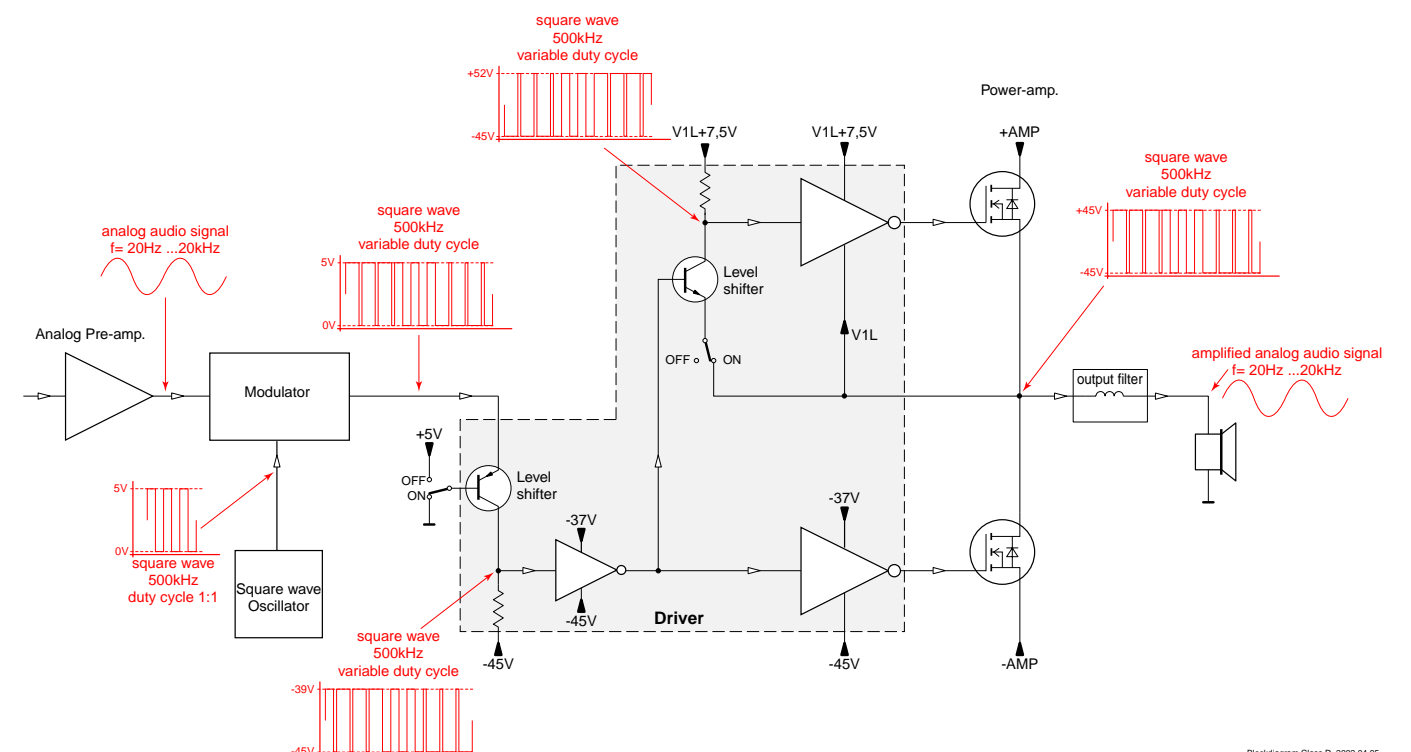

All above mentioned circuitries are located inside the metal shielding box.

Power 2003 Module

(75 - 150W Class D)

stage M.6/C.4

TABLE OF CONTENTS

Brief Circuit Description.....11-1
 Service Hints11-2

COMBI BOARD

Circuit Diagram

Overview11-4
 Source Selector part.....11-5
 Audio Frequency & Logic part11-6
 Oscillator & Pre-Amplifier part11-7
 Amplifier part Left Channel11-8
 Amplifier part Right Channel.....11-9

Component Layout

Copperside view11-10
 Componentside view.....11-12

MAINS BOARD

Component Layout11-14
 Circuit Diagram11-15

Partslist.....11-16

Class-D Circuit Description (BASED ON POWER 2003 MODULE 75-150W CLASS D)

Functional Description:

Refers to the left channel in schematic diagrams. The first stage of the modulator is an error integrator which compares the input to the (24 dB amplified) output signal of the power stage. The difference is leading to a current, which loads the integrator 7122-A. The second stage (7122-B) adds the 500kHz rectangular oscillator signal, creates high gain and low distortion and is again integrating. The output signal leads to a triangle wave form (see oscillogram (E)). The DC value of this triangle signal is floating, dependent on the amplitude of the analog input signal. The next stage is a comparator, which compares the integrated voltage with the internal switching levels - thus creating a voltage controlled duty cycle. 7122 C and D improve the shape of the pulses. For details see oscillograms (A)-(F). At pin 8 of IC7122 there is a square wave with the same frequency and duty cycle as the desired output.

The next task is to feed this information to the output FETs. Both FETs are n-channel types, so they are modulated by feeding the gate in respect to the source connection. Inverters 74LV14 are used as drivers. The driver for the low-side FET (7121) is supplied by the negative supply -VL2 and a voltage +VL (generated by 7115 and 6113), which is 7.5V higher than -VL2. The digital signal is level-shifted by 7128 to the low side driver stage. 3142, 6111 and 2126 together form a delay circuit for rising edges by approx. 100ns for the low side FET. 3154, 6109 and 2137 delay the rising edge by 50ns for the high side FET. This to compensate the switch-off delay of the FETs and ensures that both FETs are not conducting at the same time.

The high-side FET (7109) is controlled by the inverted signal taken from pin 2 of 7118, which is level-shifted by transistor 7119. The driver for the high-side FET is supplied by a floating voltage between the amplifier output -V1L and +V1L, created by the charge pump 6110, 2114 regulated by 7114 and 6114 to a 7.5V higher level. The pump is additionally supplied (via 3151) by +45V to ensure supply at start-up (no signal). The last stage in the gate driver consists of three gates in parallel for increased output current for the capacitive load of the FET. For additional increase of the switching speed push/pull transistors 7132/7111 are added.

Protection Circuits:

The amplifier is protected against low load impedance (including short circuit). Current is sensed by shunts 3101, 3130 in both supplies. Overcurrent at the positive supply is then sensed by 7104, the negative supply overcurrent triggers 7117, which then also triggers 7104. The collector current in turn triggers the monoflop 7122-5 and -6, giving a "High" pulse at pin 10. This shuts off level-shifter 7128 and blocks transistor 7129 and 7131, which draws current into the emitter resistor 3134 of level-shifter 7119. It is now also shut off. So, both FETs are shut off within approx. 0,2 sec. The monoflop can be reset by:

- switching mains off and on again
- pressing Standby button and afterwards any source button
- plugging headphone in for a short moment

When a headphone is used the amplifier is shut off. This is done by pulling pin 13 of 7122 via signal line "AMP_OFF" and transistor 7130 to high level. The line "AMP_OFF" is controlled by the port expander 7406 which detects the headphone via signal line "HP_DET".

The loudspeakers are protected against DC voltages resulting e.g. from defective FETs. Voltages higher than ±2V are detected by 7110 respectively 7112. The transistors conduct and pull the "DC_PROT" line down, blocking transistor 7243 which in turn disables speaker relay 1201.

Adjustments:

The gain of the class-D amplifier is 24dB, adjusted by the feedback resistors 3155, 3136, 3149 and the input resistors 3139, 3340. The input reference voltage for 7122-A is approx. half the supply, therefore 3144, 3148 are used for offset compensation. This compensation has to be fine-tuned with trimpotentiometers 3306 and 3307 to obtain <1mV DC output.

Service Hints:

The analog part of the Combi Board can be repaired without opening the metal shielding box. In case of a 'Class D' problem it is advised to disassemble the board first, desolder the metal bottom cover of the shielding box and assemble the board again. This takes a few minutes only.

To de-solder the metal bottom cover proceed as follows:

- 1)Remove top cover of shielding box to reduce heat flow
- 2)Do not use de-solder wick
- 3)Simply hold the board upright down as shown in picture 1. Heat up solder joints and move tip of soldering iron slowly along the edge of the metal frame. Solder will flow along the soldering tip and rest on the metal plate. A small amount will drop off. A small gap will become visible as indication that the solder connection is released. When all solder joints are released the cover can be removed by help of a screwdriver. Begin at the corner indicated by an arrow → see picture 2.

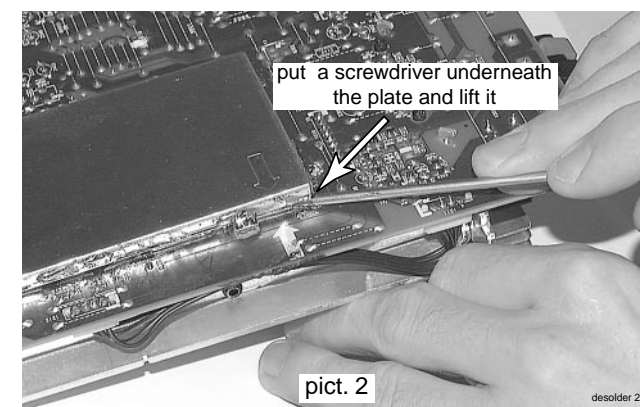
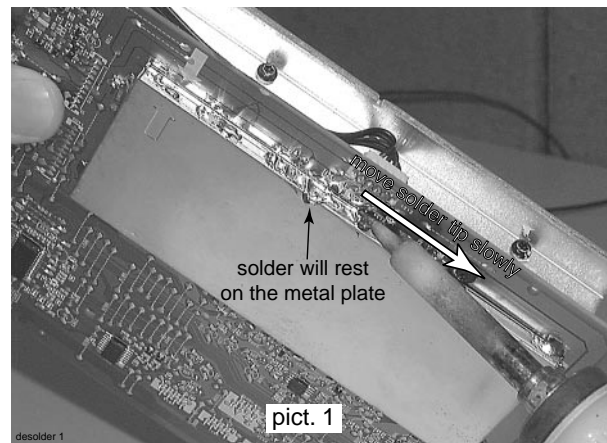

To re-mount the metal bottom cover proceed as follows:

- 1)The solder connections are not distributed evenly. Therefore the cover has to be mounted in that way that the arrow indicator on the cover is positioned in line with the arrow printed on the printed board → see picture 3.

Service Hints

- 2)Press the metal cover smoothly down until the gap between cover and printed board becomes a minimum. This is important for proper shielding.
- 3)Heat up the residual solder on the metal cover. The solder will flow back to the solder areas. If necessary apply additional new solder.
- 4)Take care that all solder joints are re-soldered again.

Attention: Poor soldering of the metal shielding box results in disturbance of the tuner.

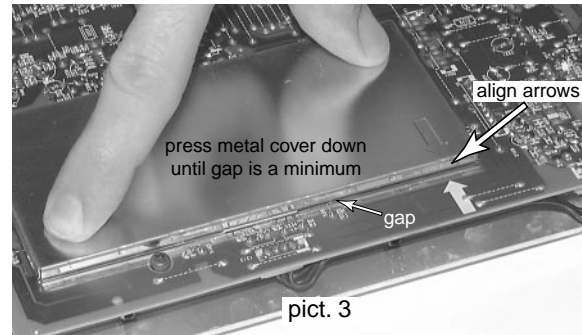

In most cases the FETs 7109 and/or 7121 for the left channel, respectively 7218 and/or 7231 for the right channel will be defective. This can easily be checked with an ordinary Ohm-meter.

LEFT CHANNEL:

In case **7109** is defect replace following parts: 7109, 7111, 7132, 7105, 7119, 7104, 3101, 3103 and 2106

In case **7121** is defect replace following parts: 7121, 7113, 7133, 7118, 7117, 3129, 3130 and 2118

RIGHT CHANNEL:

In case **7218** is defect replace following parts: 7218, 7221, 7244, 7209, 7228, 7208, 3205, 3209 and 2206

In case **7231** is defect replace following parts: 7231, 7210, 7245, 7235, 7227, 3241, 3243 and 2220

If none of the FETs is defective the fault is most probably located in the modulator. To check the operation - follow the given signals.

General description of Oscilloscope setup:

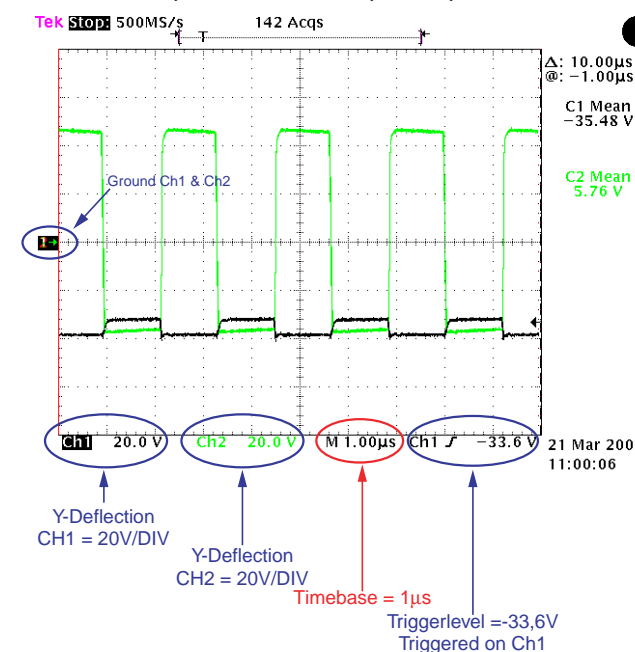

The following signals are measured on condition: AUX in = 500mV/1kHz, Volume = -28dB Load = 2 x 6Ω

Measuring point (A) can be found on circuit diagram [3]. All other measuring points are shown on circuit diagram [4] respectively [5].

Measuring point (A): Output pre-amplifier

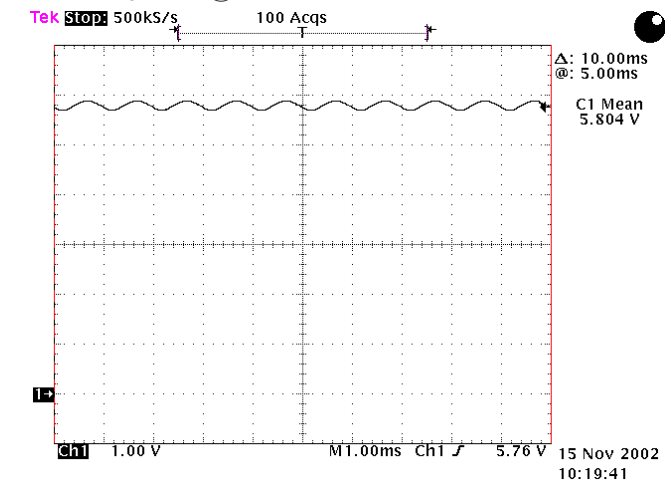

Normal analog signal measured (1kHz- Timebase 1µs). If this signal can't be measured - the fault is outside the shielding box.

Measuring point (B): Input Modulator

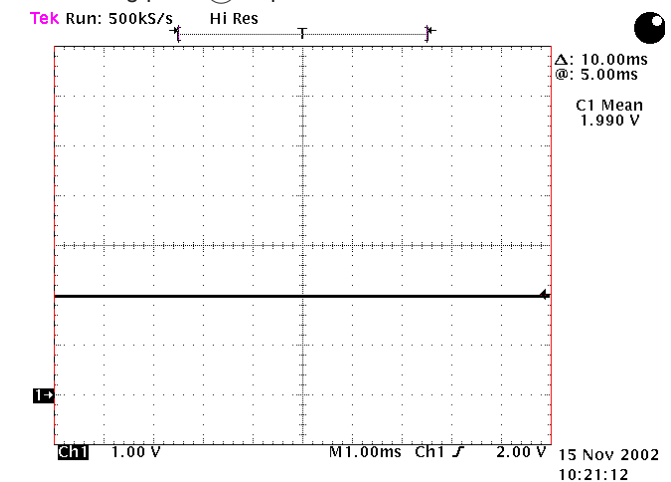

The 1kHz signal is not visible anymore. Reducing the timebase to 1µs shows the oscillogram below.

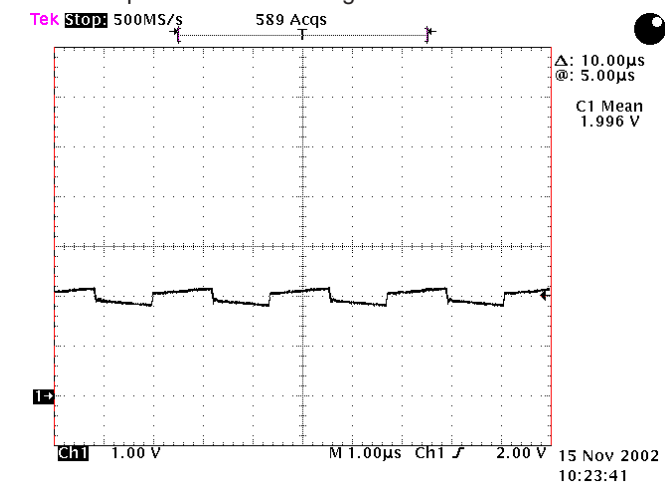

Service Hints

Measuring point (C):

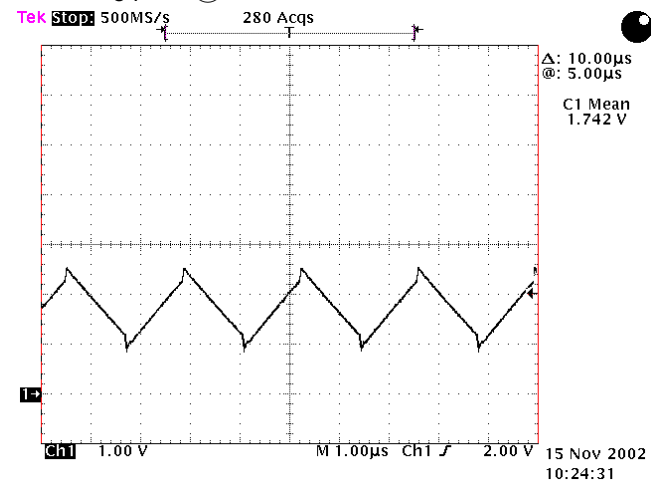

The first stage of the modulator is an integrator. An integrated rectangle results in a triangle.

Measuring point (D):

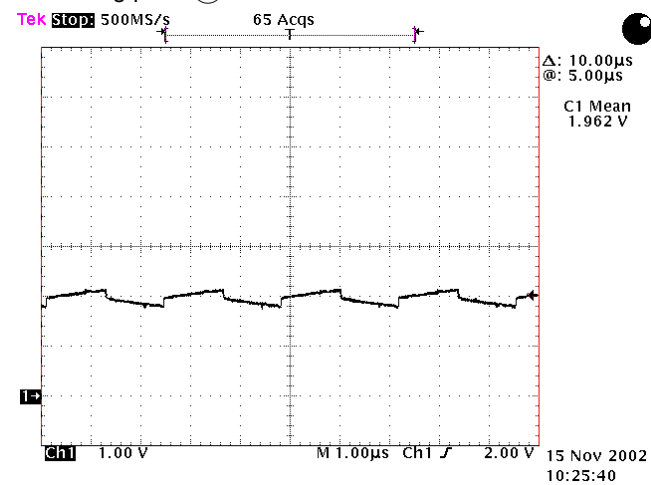

The oscillator signal (squarewave) is fed to the second integrator (7122-B).

Measuring point (E):

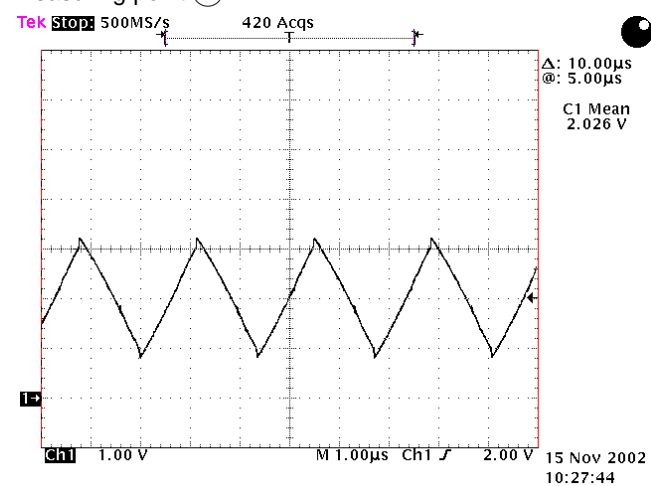

The integrated rectangle results in a triangle. 7122-C works as a comparator. 7122-D improves the shape of the pulses.

Measuring point (F): Output modulator

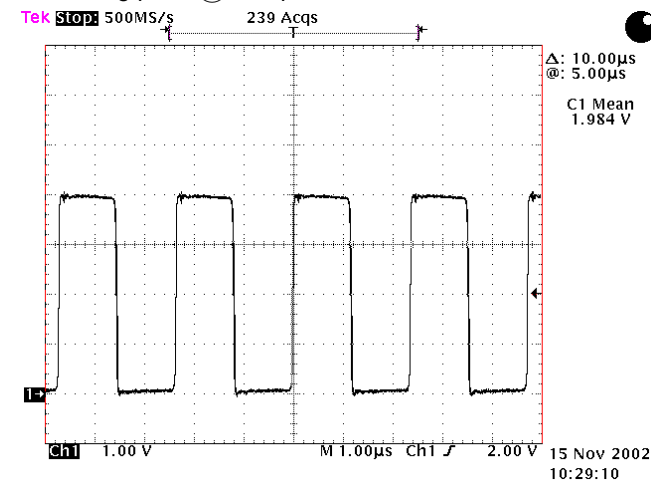

In this pulse width modulated square wave the analog Audio signal is included. Measurements with an analog scope will show a jitter on the falling edge.

The modulator frequency is still fixed to 500kHz. Similar to a frequency modulation - in this case the amplitude of the analog audio signal varies the pulse width, the frequency defines the speed.

Measuring point (G):

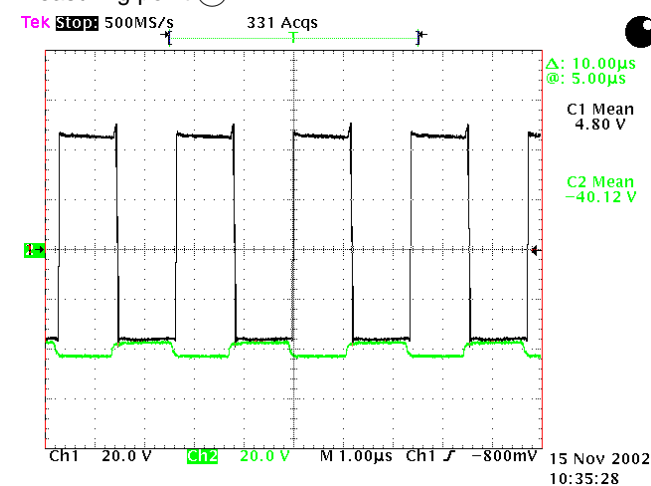

The low-side driver signal <G1> (Ch2) is the modulator output level-shifted by transistor 7128. The high-side driver signal <G2> (Ch1) is the inverted low-side driver signal level-shifted by transistor 7119.

Service Hints

Measuring point (H): gate-signal of the FETs

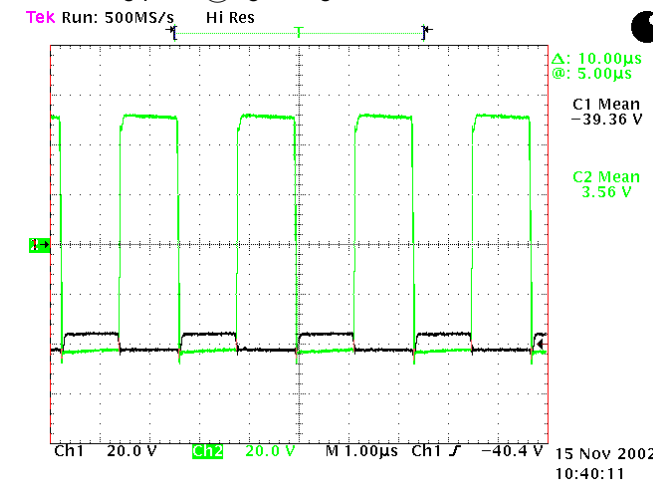

Ch1 = H1, CH2 = H2

Measuring point (I):

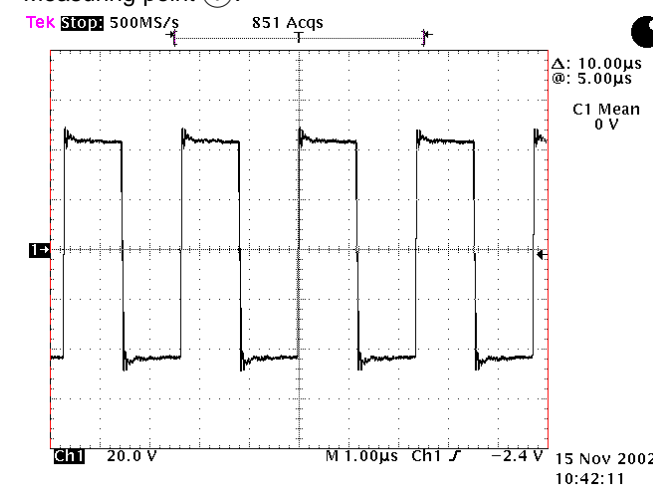

Digital output signal.

Measuring point (J):

The following three signals are measured after output filter 5101 with different timebases.

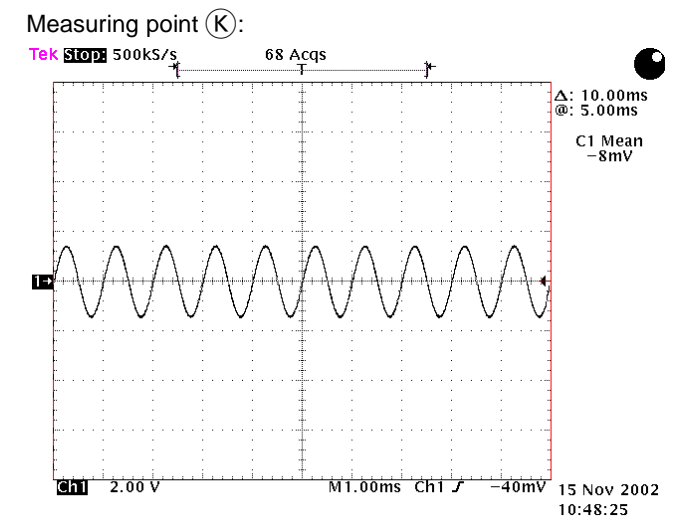
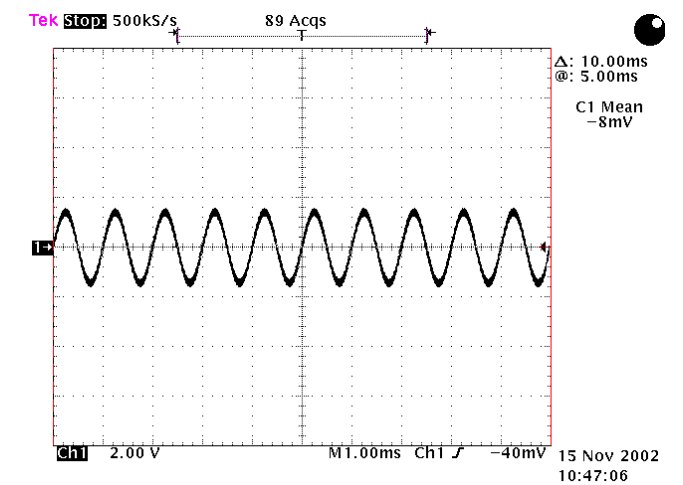
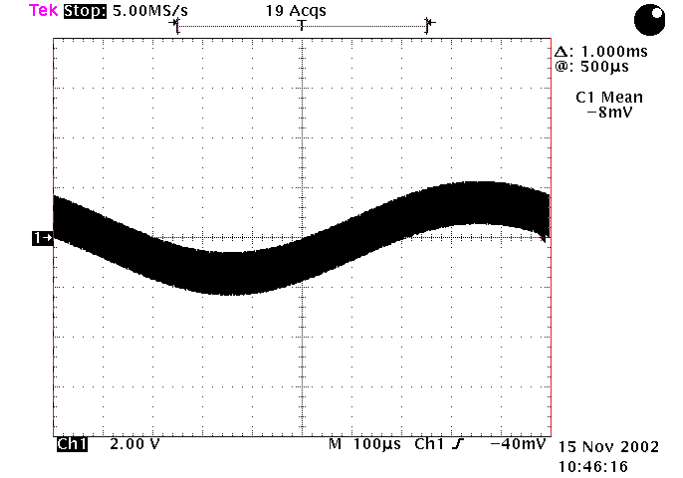
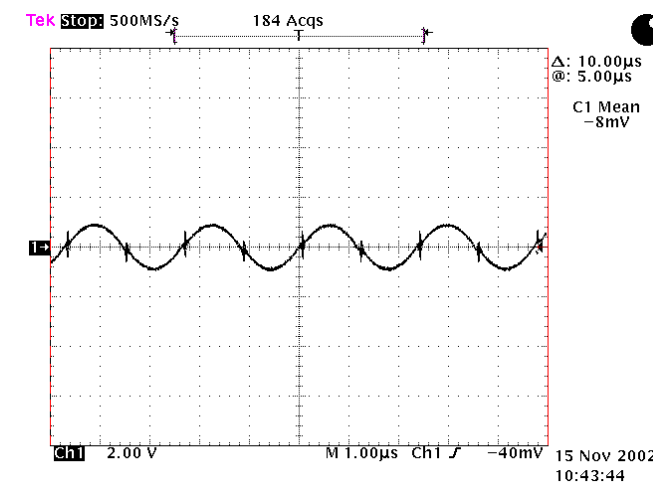

After common mode coil 5102 - the audio signal is restored.

Power 2003 75 - 150W Class D Combi Board Circuit Diagram Overview

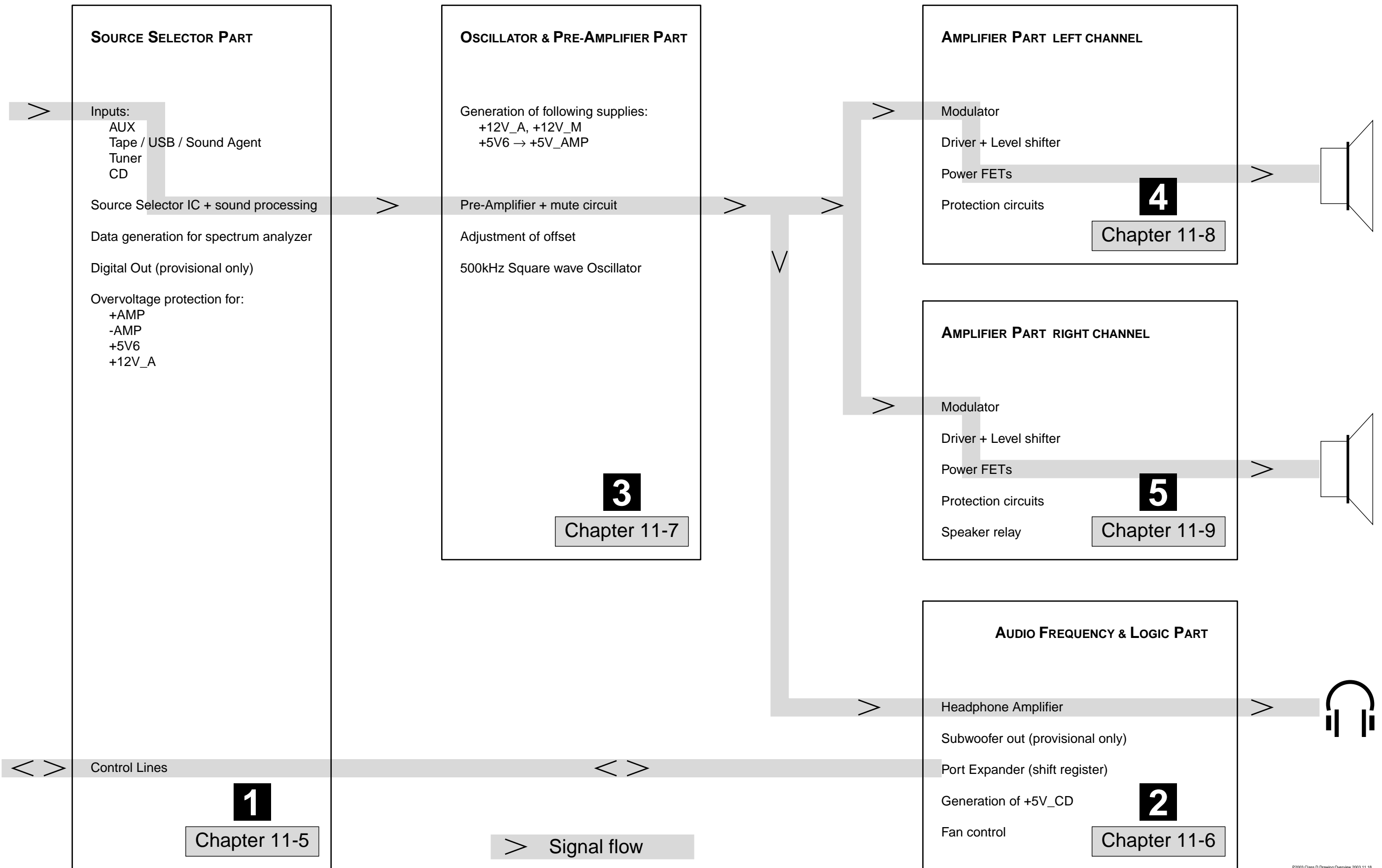

1002 A15	1018 F1	2519 B1	2534 B3	2543 D8	2556 E3	2565 G5	2576 H8	2586 A5	3501 C3	3514 A3	3524 A10	3533 C2	3549 E6	3558 F13	3568 G6	3577 H8	3586 B6	6503 G13	7500-4 B12	7512 A5	F028 C2	F038 E2	F047 F2	F060 B15	F069 D15	F078 E11	F092 A14
1005-1 A1	1020 D1	2520 A2	2536 B3	2546 D8	2557 F3	2566 G6	2577 H8	2587 A7	3502 C3	3515 A13	3525 B3	3534 C5	3549 E6	3559 F14	3569 G12	3578 H9	3587 A5	6504 G13	7500-5 B11	F020 A1	F029 C1	F039 F2	F048 F2	F061 C15	F070 D15	F079 F10	
1005-2 A1	1022 B1	2526 A13	2536 B10	2547 D10	2558 F11	2567 G6	2578 H7	2588 A7	3504 A2	3517 A14	3526 B10	3535 C8	3551 E10	3560 F6	3570 G13	3579 H10	3588 B5	6505 G12	7500-6 A11	F021 A2	F031 D2	F040 F2	F049 F2	F062 C15	F071 E15	F080 G11	
1006 A15	1026 E15	2527 A14	2537 C3	2550 D8	2559 F3	2568 G13	2579 H10	2589 A6	3506 E12	3518 A2	3527 B3	3536 C8	3552 F6	3561 G12	3571 H8	3580 D8	3589 B7	6506 E13	7505 B10	F022 A1	F032 D2	F041 F2	F050 F2	F063 C15	F072 E15	F082 E6	
1010 B15	1027 G1	2528 A3	2538 B12	2551 D9	2560 G4	2569 H8	2581 D13	2590 B6	3507 E12	3519 A2	3528 B11	3539 D9	3553 F6	3562 G13	3572 H10	3581 G7	3591 F12	6507 F12	7506 E12	F023 B1	F033 D2	F042 F2	F051 G2	F064 C15	F073 E15	F083 H7	
1011 C15	1028-A B1	2529 A12	2539 B11	2552 E9	2561 G5	2570 G10	2582 D13	2591 A7	3508 F2	3520 A3	3529 B9	3542 D7	3554 F6	3563 G6	3573 G11	3582 B7	5500 A13	6508 D13	7508 E7	F024 B2	F034 E2	F043 F2	F052 G2	F065 D15	F074 H15	F088 B10	
1012 G15	1028-B A8	2531 A2	2540 C3	2553 E3	2562 G5	2571 G11	2583 G8	2592 A7	3509 F2	3521 A11	3530 B13	3543 D9	3555 F13	3564 G6	3574 H6	3583 A7	6500 C3	7500-1 A12	7509 G14	F025 C1	F035 E2	F044 F2	F053 G2	F066 D15	F075 E15	F089 D13	
1013 D1	2500 A3	2532 A13	2541 D6	2554 D10	2563 G5	2572 H9	2584 D8	2593 H9	3510 F3	3522 B2	3531 B9	3544 D10	3556 F13	3566 G11	3575 H8	3584 A6	6501 C5	7500-2 A12	7510 A6	F026 C2	F036 E2	F045 F2	F058 B15	F067 D15	F076 E15	F090 A14	
1015 F1	2501 A8	2533 B13	2542 D7	2555 E6	2564 G5	2574 H9	2585 F6	2590 A2	3511 F3	3523 B2	3532 B10	3545 D3	3557 F6	3567 G12	3576 H7	3585 A7	6502 F14	7500-3 B12	7511 A6	F027 C1	F037 E2	F046 F2	F059 B14	F068 D15	F077 D1	F091 A14	
1	2	3	4	5	6	7	8	9	10	11	12	13	14	15													

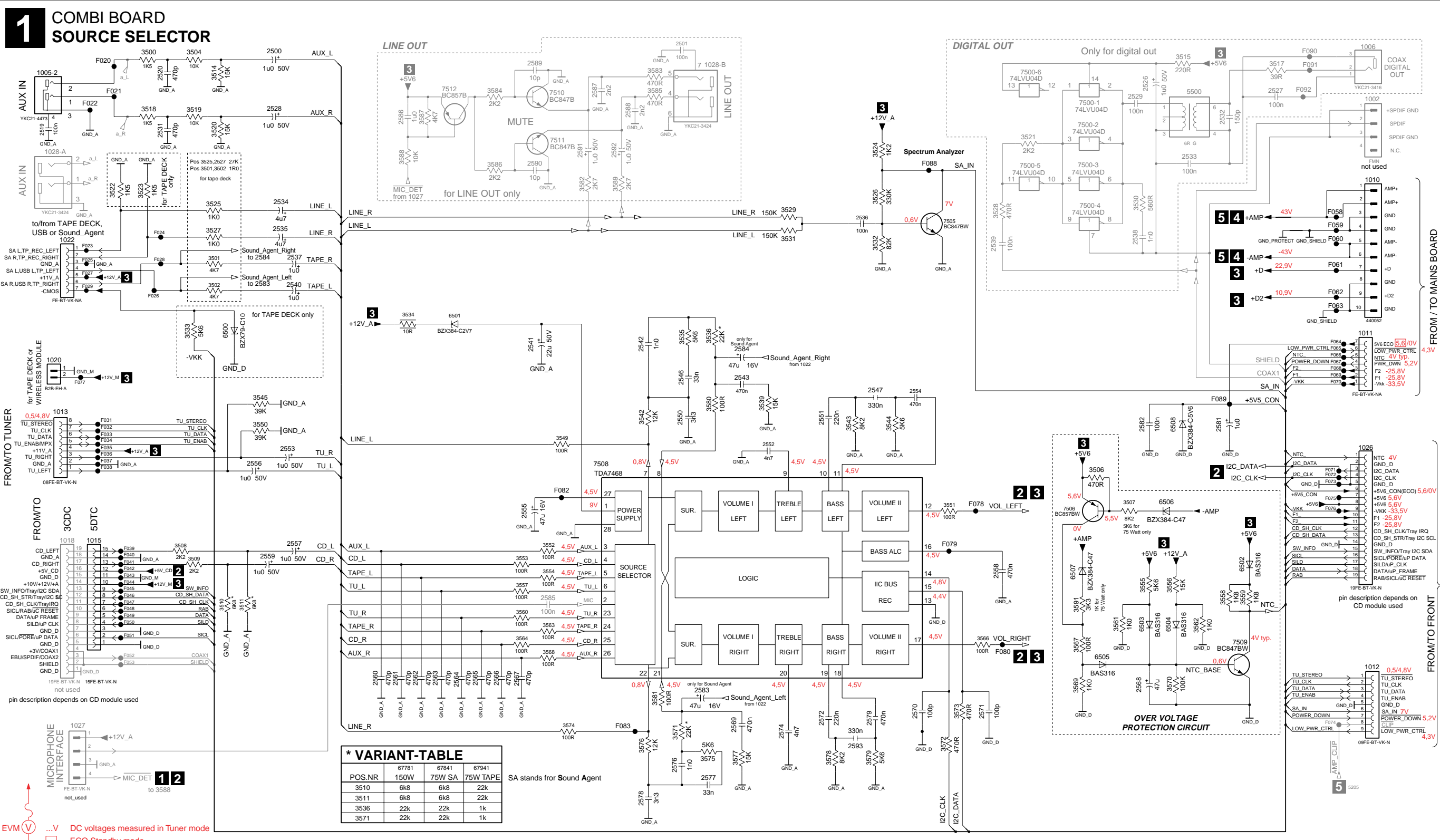

*** VARIANT-TABLE**

POS.NR	67781	67841	67941
3510	6k8	6k8	22k
3511	6k8	6k8	22k
3536	22k	22k	1k
3571	22k	22k	1k

SA stands for Sound Agent

EVM ...V DC voltages measured in Tuner mode
 ECO Standby mode

2 COMBI BOARD AUDIO FREQUENCY & LOGIC

A
B
C
D
E
F

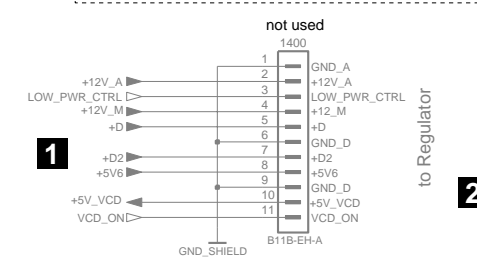
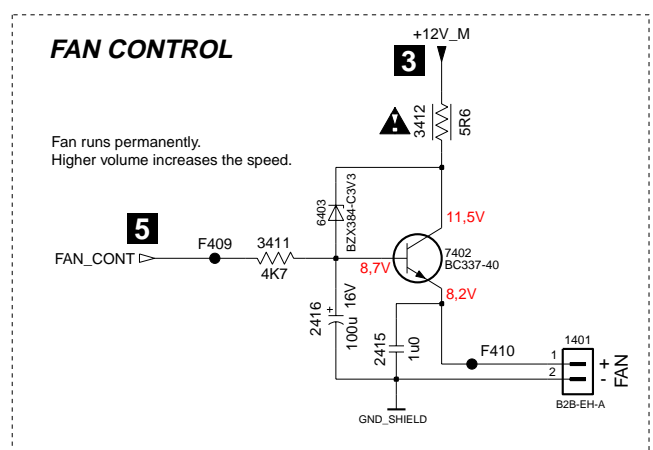
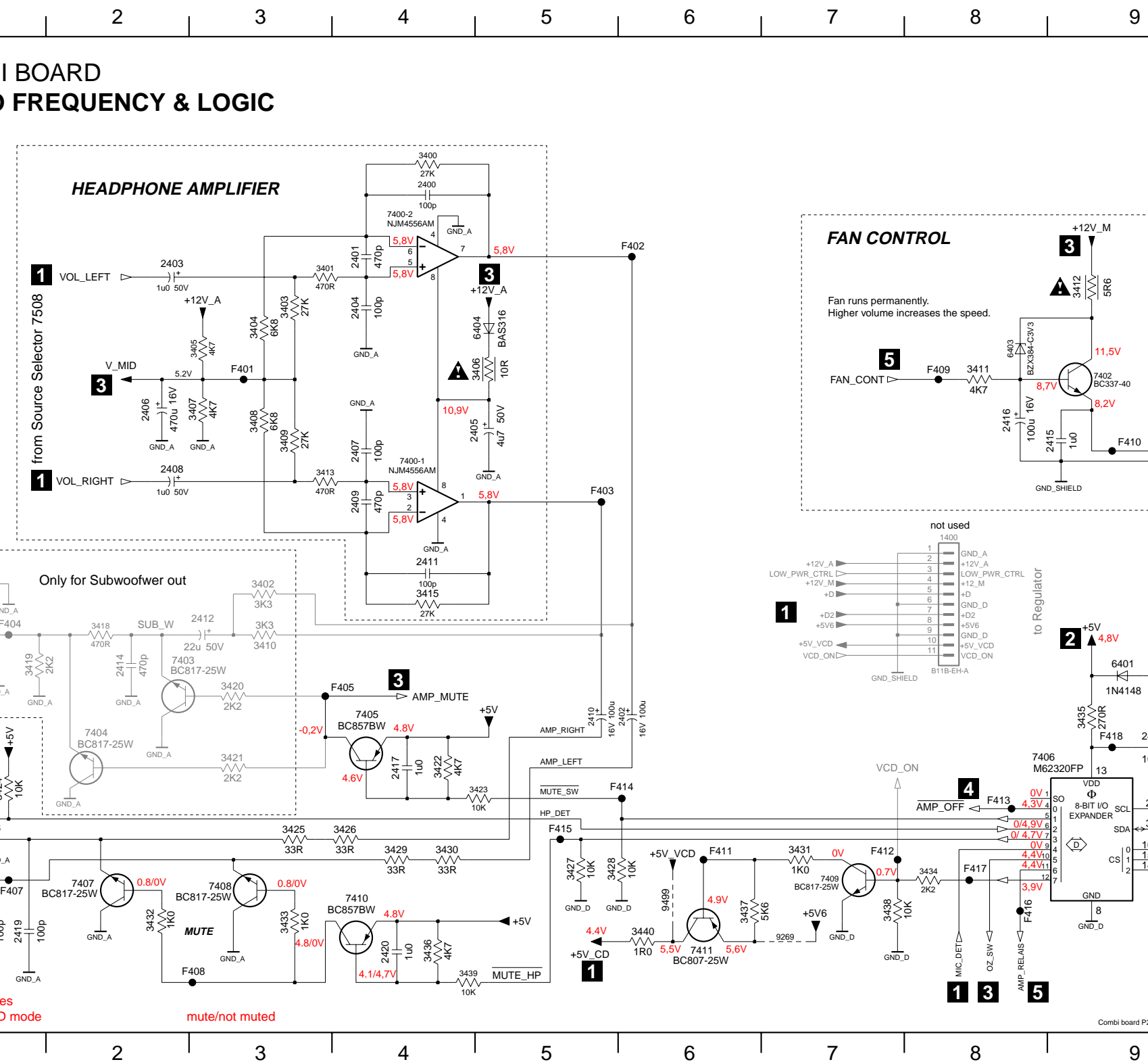

- 1004 D1
- 1014 E1
- 1400 C8
- 1401 C9
- 2400 A4
- 2401 A4
- 2402 D6
- 2403 A2
- 2404 B4
- 2405 B5
- 2406 B2
- 2407 C4
- 2408 C2
- 2409 C4
- 2410 D5
- 2411 C4
- 2412 D3
- 2413 C1
- 2414 D2
- 2415 C9
- 2416 B8
- 2417 E4
- 2418 F1
- 2419 F1
- 2420 F4
- 2421 E9
- 3400 A4
- 3401 A3
- 3402 D3
- 3403 B3
- 3404 B3
- 3405 B3
- 3406 B5
- 3407 B3
- 3408 B3
- 3409 C3
- 3410 D3
- 3411 B8
- 3412 A9
- 3413 C3
- 3415 D4
- 3418 D2
- 3419 D1
- 3420 D3
- 3421 E3
- 3422 E4
- 3423 E5
- 3424 E1
- 3425 E3
- 3426 E4
- 3427 F5
- 3428 F5
- 3429 E4
- 3430 E4
- 3431 E7
- 3432 F2
- 3433 F3
- 3434 F8
- 3435 D9
- 3436 F4
- 3437 F6
- 3438 F7
- 3439 F4
- 3440 F6
- 6401 D9
- 6403 B8
- 6404 B5
- 7400-1 C4
- 7400-2 A4
- 7402 B9
- 7403 D3
- 7404 E2
- 7405 D4
- 7406 E9
- 7407 F2
- 7408 F3
- 7409 F7
- 7410 F4
- 7411 F6
- 9269 F7
- 9499 F6
- F401 B3
- F402 A6
- F403 C5
- F404 D1
- F405 D4
- F406 E1
- F407 F1
- F408 F3
- F409 B8
- F410 C9
- F411 E6
- F412 E8
- F413 E8
- F414 E6
- F415 E5
- F416 F8
- F417 E8
- F418 E9
- F419 E9
- F420 E9

EVM ...V DC voltages measured in CD mode

mute/not muted

3 COMBI BOARD SUPPLY, OSCILLATOR & PRE-AMP

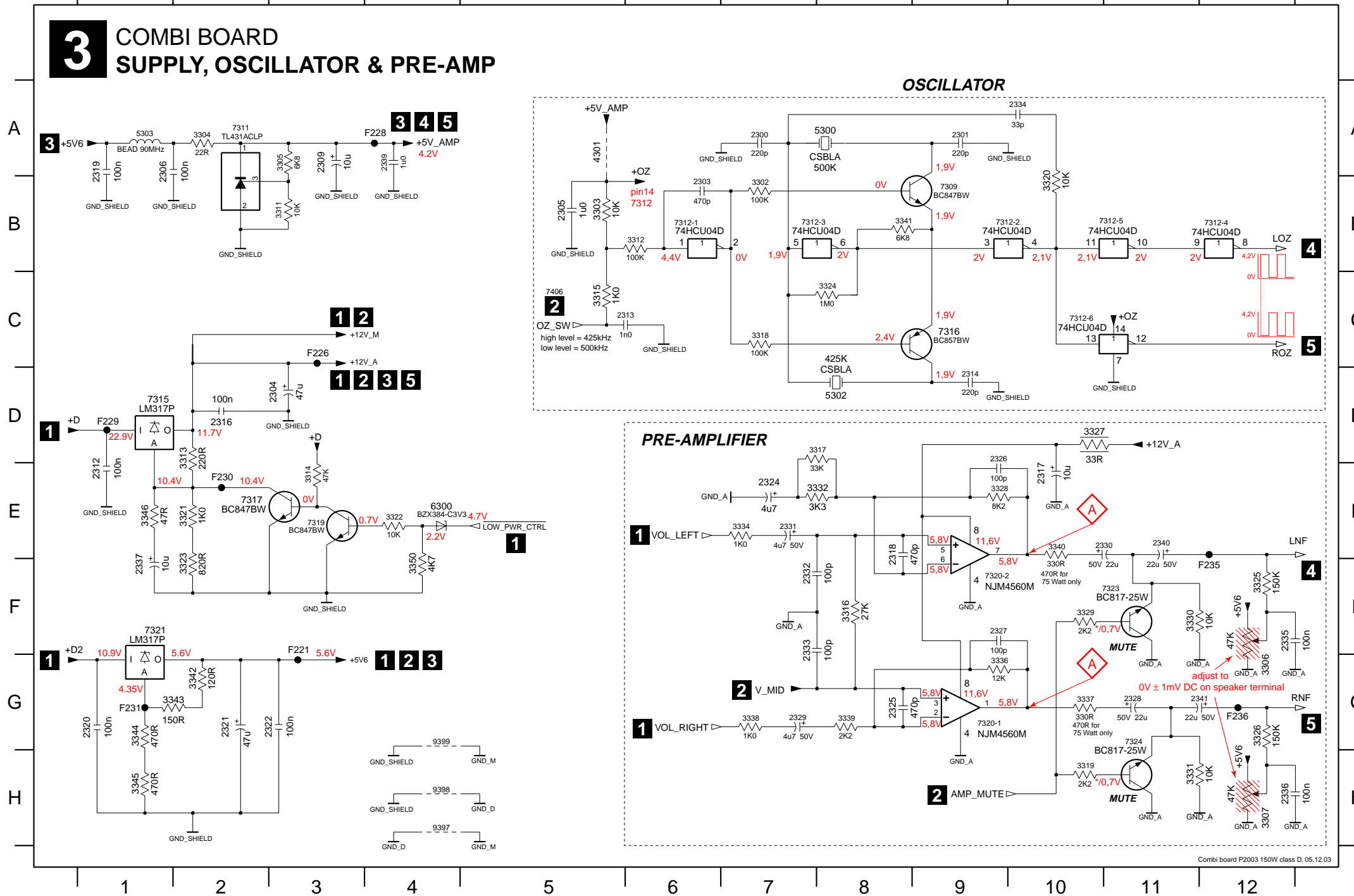

2300 A7	3346 E1
2301 A9	3350 F4
2303 B6	4301 A5
2304 D3	5300 A8
2305 B5	5302 D8
2306 A1	5303 A1
2309 A3	6300 E4
2312 E1	7309 B9
2313 C6	7311 B2
2314 D9	7312-1 B6
2316 D2	7312-2 B10
2317 E10	7312-3 B8
2318 E8	7312-4 B12
2319 A1	7312-5 B11
2320 H1	7312-6 C10
2321 G2	7315 D1
2322 G3	7316 C9
2324 E7	7317 E2
2325 G8	7319 E3
2326 D9	7320-1 G9
2327 F9	7320-2 F9
2328 G11	7321 F1
2329 G7	7323 F10
2330 E11	7324 G11
2331 E7	9397 H4
2332 F7	9398 H4
2333 F7	9399 G4
2334 A10	F221 F3
2335 F12	F226 C3
2336 H12	F228 A4
2337 F1	F229 D1
2339 A4	F230 E2
2340 E11	F231 G2
2341 G12	F235 F12
3302 B7	F236 G12
3303 B5	
3304 A2	
3305 A3	
3306 G12	
3307 H12	
3311 B3	
3312 B6	
3313 D2	
3314 E3	
3315 C5	
3316 F8	
3317 D8	
3318 C7	
3319 H10	
3320 B10	
3321 E2	
3322 E4	
3323 F2	
3324 C8	
3325 F12	
3326 G12	
3327 D10	
3328 E9	
3329 F10	
3330 F11	
3331 H11	
3332 E8	
3334 E7	
3336 G9	
3337 G10	
3338 G7	
3339 G8	
3340 E10	
3341 B8	
3342 G2	
3343 G1	
3344 G1	
3345 H1	

EVM ...V DC voltages measured in tuner mode
 ... / ... V off/on
 * ... not defined, floating

for wave forms see chapter 11-2 Service Hints

Attention:
 Adjustment to 0V ± 1mV DC has to be done with "cold" set.
 After operating a few minutes the value may increase up to 30mV.

2100 A11	2106 B12	2113 E8	2118 G12	2124 H10	2132 G9	2138 A11	3103 B11	3110 E4	3119 D9	3126 D1	3134 G6	3139 G1	3145 D11	3151 C10	3156 F10	5105 E12	6111 H8	7109 C11	7117 G12	7122-2 G4	7128 F6	7133 F11
2101 A11	2108 D3	2114 D10	2119 G3	2125 G1	2134 F14	2139 H11	3106 C12	3111 C9	3120 G10	3127 H6	3135 F10	3140 G4	3146 G7	3152 C9	5100 A11	6106 D9	6113 H9	7111 C10	7118 F7	7122-3 G4	7129 D6	9199 D1
2102 A10	2110 D8	2115 E14	2120 F2	2126 H7	2135 G4	3100 D2	3107 G7	3114 E3	3121 G10	3129 G11	3136 E8	3142 G8	3147 D5	3153 C9	5101 E12	6108 G9	6114 E9	7113 F10	7119 G6	7122-4 G5	7130 D2	F102 G9
2103 A10	2111 G10	2116 F12	2121 H9	2128 H11	2136 H10	3101 B11	3108 C4	3115 F6	3122 G9	3130 G11	3137 F13	3143 G5	3148 G2	3154 E8	5102 F13	6109 E8	7114 D9	7121 F11	7122-5 E4	7125 G5	7131 H6	F112 G12
2104 D1	2112 D11	2117 F14	2122 C11	2130 G11	2137 D7	3102 E6	3109 C10	3117 D7	3125 H4	3133 G7	3138 F13	3144 G2	3149 F3	3155 E8	5103 H11	6110 C10	7105 C7	7115 G9	7122-1 G3	7122-6 E3	7132 B11	F114 D14

4 COMBI BOARD AMPLIFIER / LEFT CHANNEL

*** VARIANT-TABLE**

POS.NR	67781 150W	67841/67941 75W SA / 75W TAPE	SA stands for Sound Agent
2102	220u		
2138		330u	
2119	4n7	1n5	
2124	220u		
2139		330u	
2135	470p	1n	
3101	0R033	0R047	
3109	100R	4R7	
3111	10R	1R0	
3119	10K	15K	
3120	4K7	4K7	
3121	4K7	4K7	
3130	0R033	0R047	
3135	100R	4R7	
3139	470R	560R	
3140	1K2	1K5	
3152	1K8	1K5	
3153	1K8	1K5	
3156	10R	1R0	
5101		30u	
5105	20u		
7109	PHX18N011T	STP14NF12FP	
7121	PHX18N011T	STP14NF12FP	
7132	BC817-25W		
7133	BC817-25W		

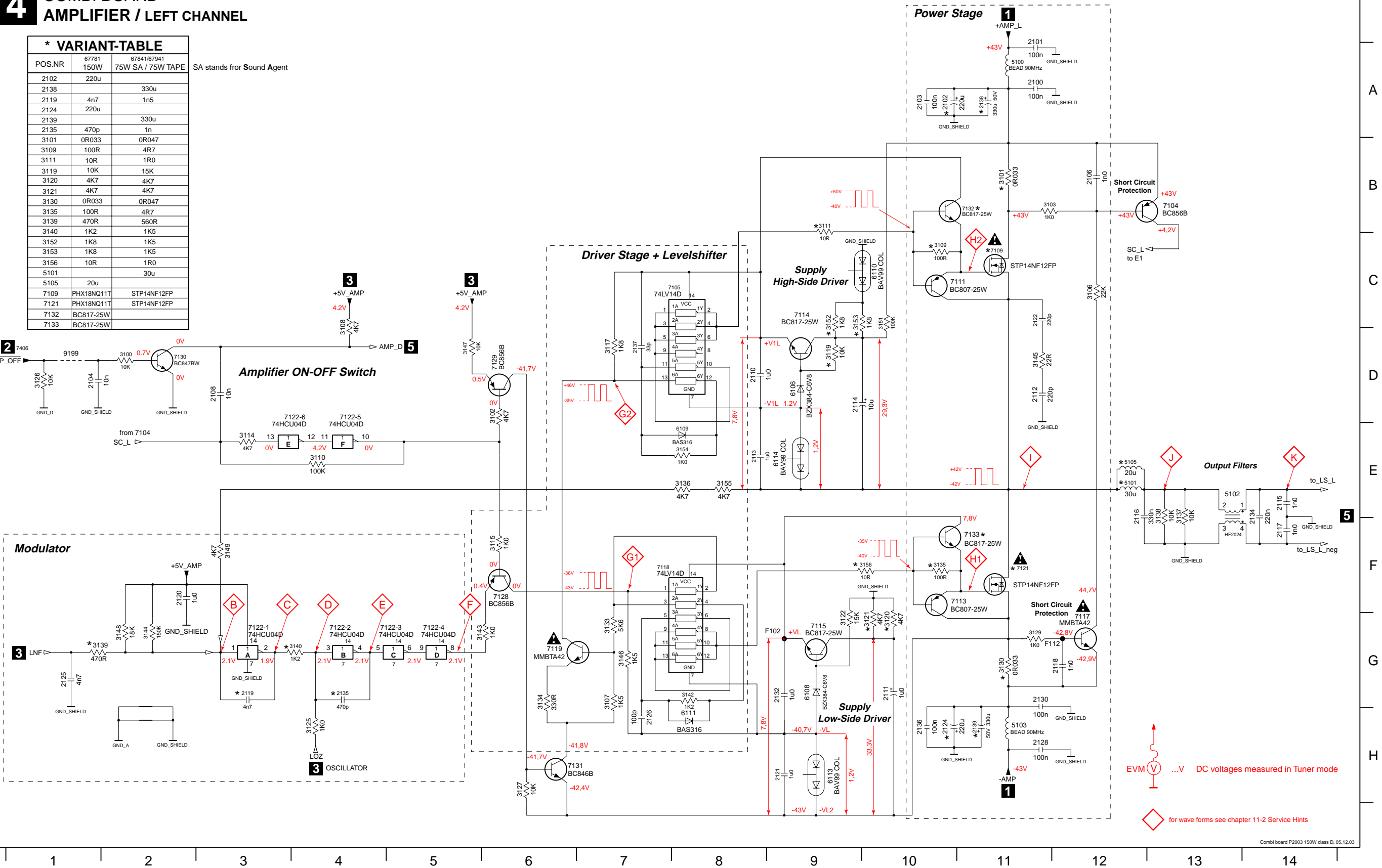

EVM ...V DC voltages measured in Tuner mode

for wave forms see chapter 11-2 Service Hints

1201 F14	1307-D F15	2205 B14	2212 D10	2218 G9	2226 F1	2238 H8	3113 G12	3207 B13	3215 C9	3223 C13	3229 D13	3241 F10	3251 F1	3258 F1	3265 C8	5201 E11	6202 B13	6211 B8	7110 G12	7211 B13	7227 F11	7232-4 G4	7240 F5	F214 E14
1211 E14	2109 G12	2206 B11	2213 G10	2219 E13	2227 H60	2239 D7	3116 G13	3209 B10	3216 C11	3224 C12	3231 F9	3243 F10	3252 G3	3259 F2	3266 C9	5202 E12	6205 C14	6212 D8	7112 G13	7218 C12	7228 E6	7232-5 D4	7243 G14	F215 G14
1212 E14	2200 A10	2208 D2	2214 D9	2220 F10	2229 G10	2240 D60	3201 B1	3210 D3	3217 D3	3225 C6	3232 F8	3245 F7	3253 H7	3261 E7	3267 D7	5203 G10	6206 D14	6213 G8	7220 C10	7231 E10	7232-6 D3	7244 B10	F216 E15	
1307-A E15	2201 A9	2209 D12	2215 E13	2221 F2	2234 E13	2241 A10	3202 B8	3211 F4	3218 D4	3226 D12	3236 D10	3246 E6	3254 F2	3262 G4	3268 E7	5204 D11	6208 H8	6214 D7	7208 B11	7221 C10	7232-1 F2	7235 F7	7245 E9	F217 E15
1307-B E15	2202 A10	2210 D7	2216 E11	2222 F3	2236 G8	2242 G10	3203 B14	3212 F9	3219 C13	3227 D5	3237 E11	3247 E9	3255 G5	3263 G13	3269 E8	5205 C11	6209 D12	6216 F14	7209 B6	7222 C8	7232-2 G3	7238 G6	F201 D4	F218 E15
1307-C E15	2203 A9	2211 G9	2217 C1	2225 G9	2237 G3	3112 G12	3205 B10	3213 G3	3221 G5	3228 C8	3240 E12	3248 E7	3256 G6	3264 C9	5200 A10	6104 G12	6210 D8	6217 H7	7210 F9	7223 F8	7232-3 G4	7239 D5	F212 F10	F219 E15

5 COMBI BOARD AMPLIFIER / RIGHT CHANNEL

*** VARIANT-TABLE**

POS.NR	67781	67841/67941
2201	220u	
2241		330u
2221	4n7	1n5
2225	220u	
2242		330u
2237	470p	1n
3202	10R	1R
3205	0R033	0R047
3215	100R	4R7
3228	10K	15K
3212	4K7	4K7
3231	4K7	4K7
3243	0R033	0R047
3247	100R	4R7
3251	470R	560R
3252	1K2	1K5
3265	1K8	1K5
3266	1K8	1K5
3269	10R	1R0
5201		30u
5204	20u	
7218	PHX18N011T	STP14NF12FP
7231	PHX18N011T	STP14NF12FP
7244	BC817-25	
7245	BC817-25	

SA stands for Sound Agent

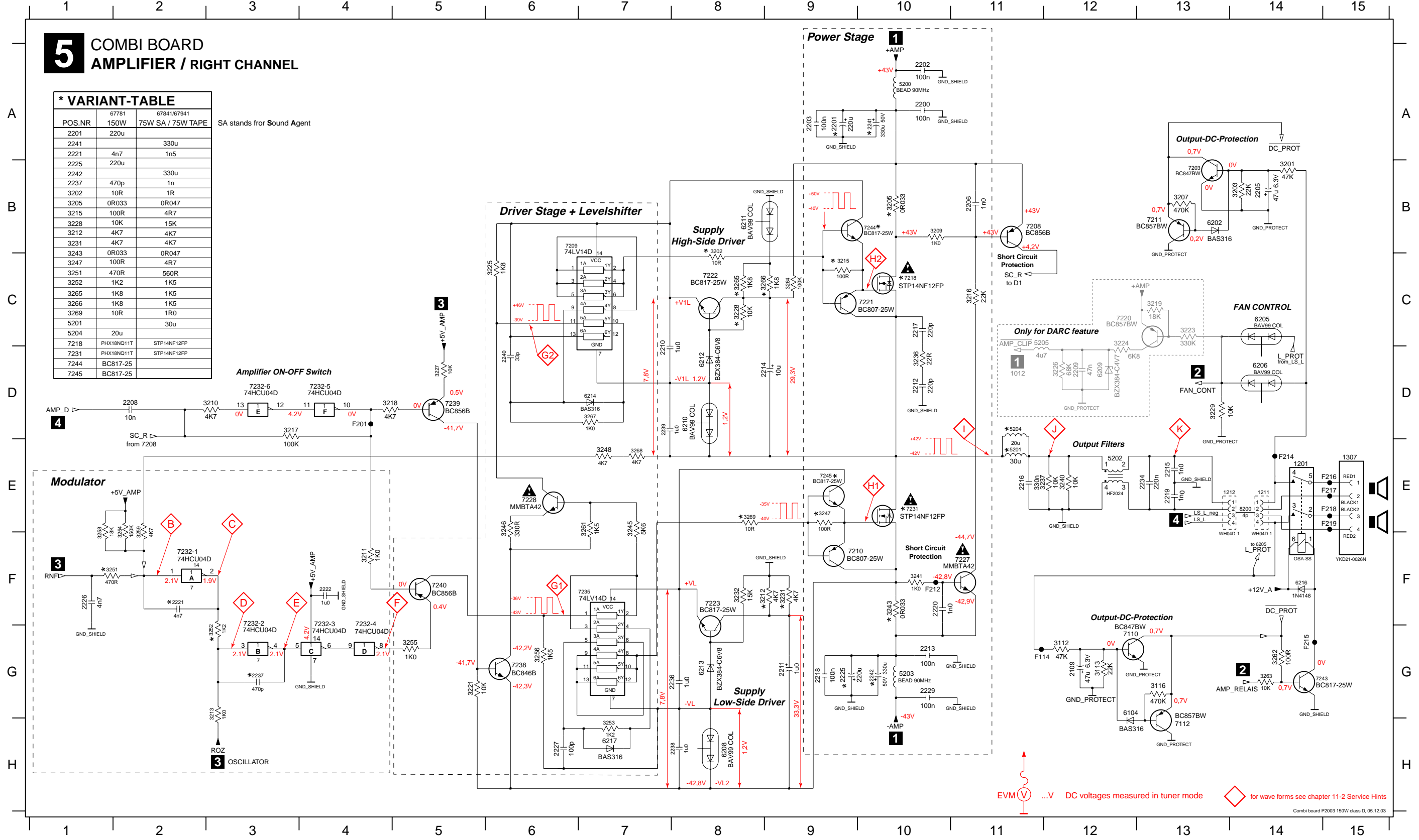

EVM ...V DC voltages measured in tuner mode ◇ for wave forms see chapter 11-2 Service Hints

1002 A9	1013 A5	1027 B1	1401 D9	2134 H4	2216 F6	2317 D3	2337 F10	2408 C4	2534 B3	2556 B5	2591 C10	3307 D5	3440 B9	5103 H3	5300 E4	7109 H1	7402 E9	9211 C2	9219 D3	9227 C6	9235 D6	9242 F10	9249 E8	9257 D3	9266 A8	9278 F9	9287 C8	9296 B2	9499 C9	9815 A1	9825 G5
1004 D11	1014 D1	1028 C11	2102 G1	2138 G1	2225 G7	2321 F9	2340 D2	2410 D1	2535 B3	2557 B9	2592 B11	3315 E5	3534 C8	5105 G2	5302 E4	7121 H2	9199 D5	9212 B9	9220 A5	9228 C5	9236 C2	9243 C8	9250 H8	9258 H4	9267 H7	9279 F9	9289 C10	9297 G2	9801 C7	9816 B1	9827 B4
1005 C11	1015 A8	1201 G10	2109 H8	2139 G3	2234 H4	2324 C3	2341 D4	2412 D10	2537 B4	2559 C8	3190 E6	3327 C3	3572 A8	5200 H5	5303 D5	7218 H6	9206 E6	9213 C3	9221 A5	9229 D6	9237 D6	9244 E4	9251 E8	9259 H4	9268 B10	9280 C6	9288 B6	9802 C8	9817 B9		
1006 B11	1018 A9	1211 H3	2111 F3	2201 G5	2241 G5	2328 D3	2402 C1	2418 D9	2540 G5	2568 B1	3139 E2	3329 D3	3573 A7	5201 G6	5300 B11	7231 H7	9207 A1	9215 B2	9222 F10	9230 D5	9238 B8	9245 E2	9252 E10	9261 F8	9270 H3	9282 C9	9291 C10	9299 B6	9803 D8	9819 C6	
1010 G8	1020 B9	1212 H4	2114 F2	2205 H9	2242 G7	2329 D4	2403 C5	2500 C10	2541 C8	2581 B1	3251 E5	3406 C1	5100 G1	5202 G5	6216 F10	7311 H4	9208 B3	9216 B3	9224 C5	9231 C7	9239 B8	9246 E2	9254 A8	9262 G8	9275 E9	9283 D6	9292 E10	9397 A9	9805 A6	9820 C9	
1011 A4	1022 B4	1307 F11	2116 F1	2211 F7	2240 F8	2330 D2	2405 C2	2502 B10	2543 B4	2583 A6	3304 E5	3411 D10	5101 G2	5203 G8	6401 C5	7315 F9	9209 B4	9217 B6	9225 D5	9232 B6	9240 C7	9247 D8	9255 B2	9264 F8	9276 H9	9285 D8	9294 B2	9398 A10	9806 B6	9821 B9	
1012 A3	1026 A2	1400 E8	2124 G3	2214 F5	2309 E4	2331 C4	2406 C2	2528 C10	2555 C7	2584 B9	3306 D3	3412 E9	5102 G4	5204 G6	6500 A4	7321 E9	9210 C2	9218 C9	9226 C5	9234 C5	9241 G6	9248 D9	9256 D4	9265 F9	9277 B7	9286 D8	9295 A2	9399 C9	9813 B2	9824 F3	

COMBI BOARD / copperside view Layout stage .3

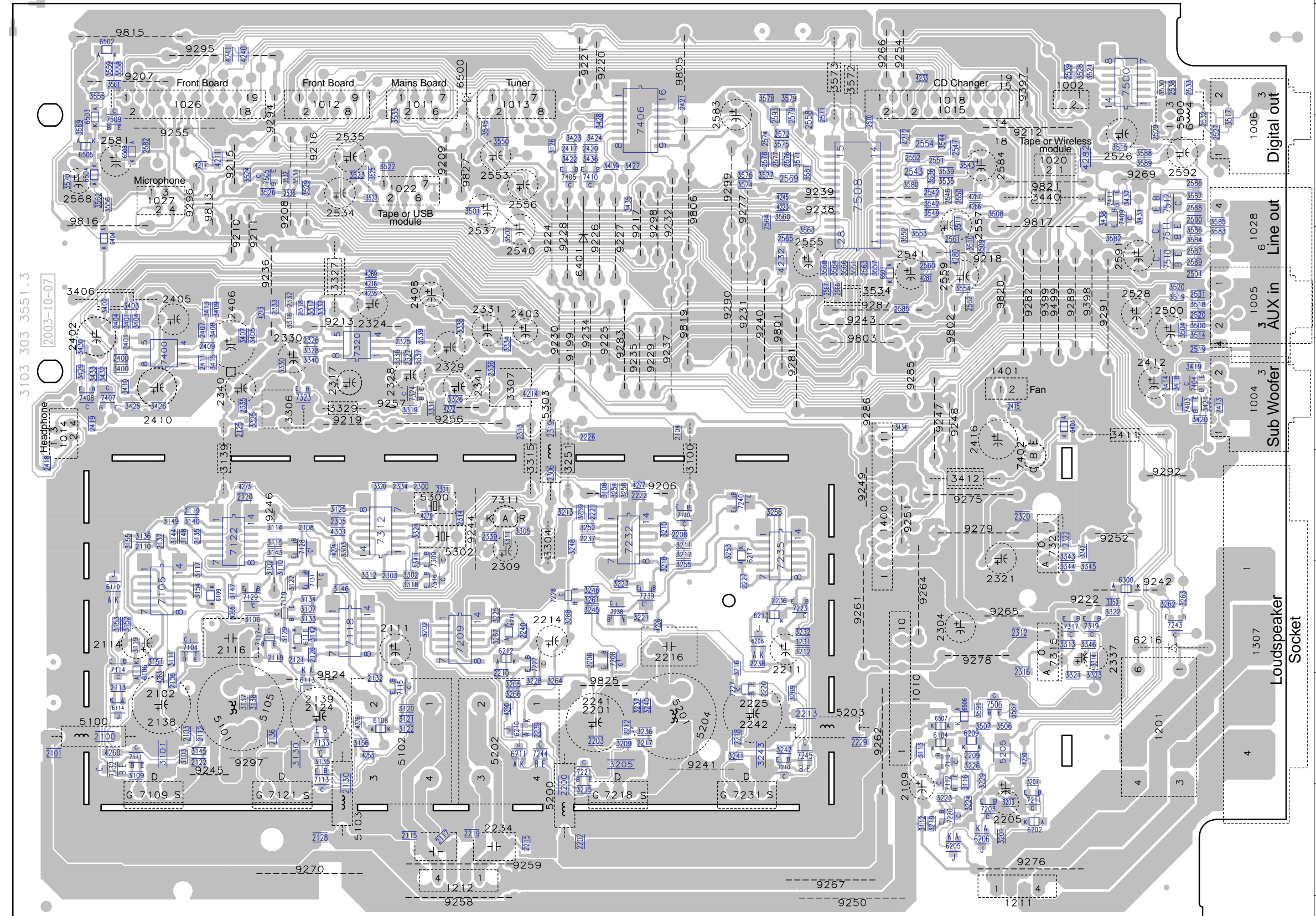

2100 G1	2587 C11	3337 D4	4216 C3
2101 G1	2588 B11	3338 C4	4217 B2
2103 G2	2589 C11	3339 C4	4223 B7
2104 D6	2590 B11	3340 D3	4226 F6
2106 G2	2593 B7	3341 F4	4230 G9
2108 E3	3101 G1	3342 E10	4232 C7
2110 E1	3102 F2	3343 E10	4233 A8
2112 G2	3103 G2	3344 F10	4235 C3
2113 G1	3106 F2	3345 F10	4240 A2
2115 H4	3107 F3	3346 F10	4241 A2
2117 H4	3108 E5	3350 F10	4245 B7
2118 F2	3109 G1	3400 D1	4253 G3
2119 E2	3110 F2	3401 C1	4260 G1
2120 E2	3111 F1	3402 C1	4265 F2
2121 F3	3112 H8	3403 C1	4272 D4
2122 G2	3113 G8	3404 C1	4273 E2
2125 D2	3114 E2	3405 C2	4274 E3
2126 F3	3115 E2	3407 C2	4276 G3
2128 H3	3116 G9	3408 C2	4277 E6
2130 G3	3117 F2	3409 C2	4279 E4
2132 G3	3119 F1	3410 D1	4280 C9
2135 E2	3120 G4	3413 C2	4281 C8
2136 G2	3121 G4	3415 D2	4282 B10
2137 E1	3122 G4	3418 D11	4283 G1
2200 H5	3125 C3	3419 D11	4286 B9
2202 H5	3126 B5	3420 D11	4287 B9
2203 G5	3127 F3	3421 D11	4289 C3
2206 F5	3129 F3	3422 B5	4290 G5
2208 E6	3130 G3	3423 B5	4301 E3
2209 G9	3133 F3	3424 B5	4305 G9
2210 G4	3134 F3	3425 D1	4304 G8
2212 G2	3135 G3	3426 B1	4308 F1
2213 G7	3138 E1	3427 B6	4308 G3
2215 H5	3137 G2	3428 B5	4309 F2
2217 G6	3138 G2	3429 D11	4311 F1
2218 G7	3140 E2	3430 D1	4311 G3
2219 H4	3142 F3	3431 B10	4313 G3
2220 G7	3143 E2	3432 D1	4314 G1
2221 E5	3144 E2	3433 D1	4320 H9
2222 E6	3145 G2	3434 D8	4320 H8
2226 D5	3146 F3	3435 B6	4320 H9
2227 F7	3147 F2	3436 B5	4320 F7
2229 G8	3148 E2	3437 B10	4320 G9
2236 F7	3149 E1	3438 B10	4321 G5
2237 E5	3151 F1	3439 B5	4321 F5
2238 F7	3152 F1	3500 C11	4322 F4
2239 G5	3153 F1	3501 B4	4323 F7
2240 F5	3154 F2	3502 C5	4324 F4
2300 E4	3155 E1	3504 C11	4327 E7
2301 E4	3156 G3	3506 G9	4330 F10
2303 F3	3201 H9	3507 G9	4303 D10
2304 F3	3202 F4	3508 B9	4304 F1
2306 E5	3203 H9	3509 C9	4301 C8
2312 F9	3205 G6	3510 C9	4302 A1
2313 D5	3207 G9	3511 B9	4303 A1
2314 E4	3209 G6	3514 C11	4304 A1
2316 F9	3210 E6	3515 B10	4305 B1
2318 C3	3211 E6	3517 B11	4306 G9
2319 D5	3212 F7	3518 C11	4307 G8
2320 E9	3213 E5	3519 C11	4308 B1
2322 E0	3215 H5	3520 C9	4304 F2
2325 D4	3216 H5	3521 A10	4305 F1
2326 D3	3217 E6	3522 B3	4310 G8
2327 D4	3218 F6	3523 B3	4311 G1
2332 C3	3219 H8	3524 B2	4312 G8
2333 C2	3221 F6	3525 B3	4313 G3
2334 E4	3223 H8	3526 B2	4314 F1
2335 D2	3224 H9	3527 B3	4315 G4
2336 D4	3225 F4	3528 A10	4317 F2
2339 E4	3226 G9	3529 B3	4318 F3
2400 A1	3227 F6	3530 A10	4319 F3
2401 D1	3229 G9	3531 B3	4322 F2
2404 C1	3229 G9	3532 B3	4328 E3
2407 C2	3231 F7	3533 B4	4329 F2
2409 D2	3232 F7	3535 B8	4330 E6
2411 D2	3236 G6	3536 B8	4331 G3
2413 D11	3237 G6	3539 B8	4332 G1
2414 D10	3240 G6	3542 B8	4333 G3
2415 D9	3241 G7	3543 B9	4333 H9
2417 B5	3243 G7	3544 B8	4330 F5
2418 E1	3245 F5	3545 B8	4309 F4
2419 D1	3246 F5	3546 B8	4310 F4
2420 B5	3247 G7	3550 B4	4311 H9
2421 A6	3248 E5	3551 C8	4320 H8
2501 C11	3252 E5	3552 C8	4321 G5
2519 D11	3253 E6	3553 C8	4322 F5
2520 C11	3254 E5	3554 C9	4323 F7
2527 B11	3255 F6	3555 A1	4327 G7
2529 B10	3256 E7	3556 B1	4328 F5
2531 C11	3258 E6	3557 C8	4332 E6
2532 B11	3259 E5	3558 A1	4328 E7
2533 A11	3261 F5	3559 A1	4328 F5
2536 B3	3262 F10	3560 B7	4329 F6
2538 A10	3263 F11	3561 A1	4320 E7
2539 A10	3264 G5	3562 B1	4323 F10
2542 B8	3265 G5	3563 C7	4324 G5
2543 B8	3266 G5	3564 C7	4325 G7
2546 B8	3267 F4	3566 C8	4309 E4
2547 B9	3268 F5	3567 G9	4332 E3
2550 B9	3269 G7	3568 C7	4336 F4
2551 B8	3302 F4	3569 B1	4337 F10
2552 B8	3303 E3	3570 B1	4319 F10
2554 B8	3305 E5	3571 B7	4320 D3
2558 B7	3311 E5	3574 B7	4323 D3
2560 C8	3312 F3	3575 B7	4324 D4
2561 C9	3313 F10	3576 B7	4400 D1
2562 C9	3314 F10	3577 B7	4403 D11
2563 C8	3316 C3	3578 A7	4404 D11
2564 B7	3317 C3	3579 A7	4405 B5
2565 C7	3318 F4	3580 B8	4406 B6
2566 C7	3319 D4	3581 B7	4407 D1
2567 C7	3320 E3	3582 C10	4408 D1
2569 B7	3321 G10	3583 C11	4409 B10
2570 B8	3322 F10	3584 C11	4410 B5
2571 A7	3323 G10	3585 B11	4411 B10
2572 B7	3324 E4	3586 C11	4410 A10
2574 B7	3325 D2	3587 B11	4410 B2
2576 B7	3326 D4	3588 B10	4410 G9
2577 B7	3328 D3	3589 B10	4410 B8
2578 B7	3330 D2	3591 G9	4410 B1
2579 B7	3331 D4	4211 B2	7510 C10
2582 B1	3332 C3	4212 B6	7510 C10
2585 C8	3334 D5	4213 C2	7512 B10
2586 B11	3336 D4	4214 D5	

This assembly drawing shows a summary of all possible versions.
 For components used in a specific version see schematic diagram respectively partslist.

COMBI BOARD / componentside view Layout stage .3

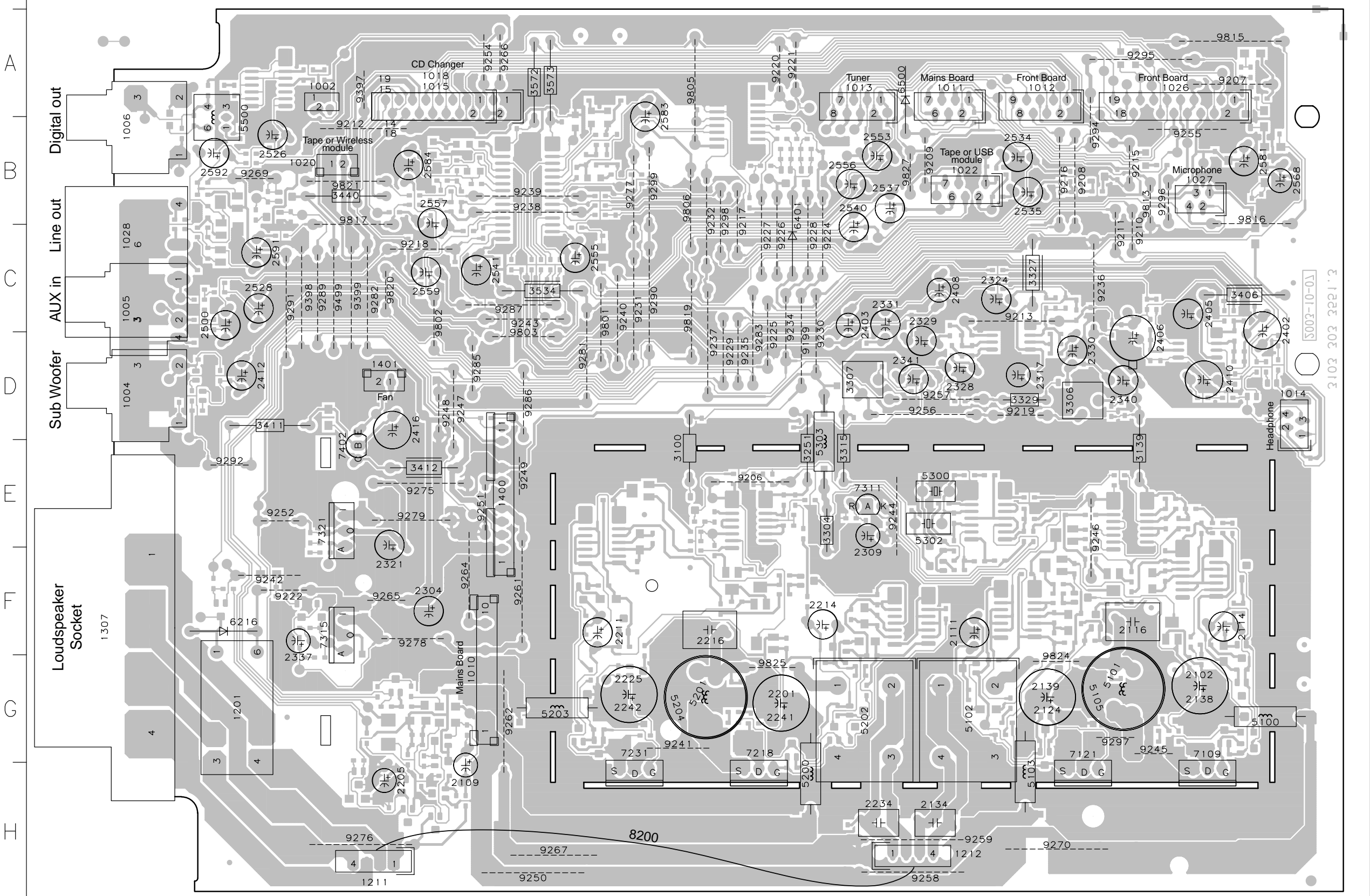

- 1002 A2
- 1004 D1
- 1005 C1
- 1006 B1
- 1010 G4
- 1011 A8
- 1012 A9
- 1013 A7
- 1014 D11
- 1015 A3
- 1018 A3
- 1020 B3
- 1022 B8
- 1026 A10
- 1027 B11
- 1028 C1
- 1201 G2
- 1211 H3
- 1212 H8
- 1307 F1
- 1400 E4
- 1401 D3
- 2102 G11
- 2109 H4
- 2111 F8
- 2114 F11
- 2116 F10
- 2124 G9
- 2134 H8
- 2138 G11
- 2139 G9
- 2201 G7
- 2205 H3
- 2211 F5
- 2214 F7
- 2216 F6
- 2225 G5
- 2234 H8
- 2241 G7
- 2242 G5
- 2304 F3
- 2309 F8
- 2317 D9
- 2321 F3
- 2324 C9
- 2328 D8
- 2329 C8
- 2330 D10
- 2331 C9
- 2337 G2
- 2340 D10
- 2341 D8
- 2402 C11
- 2403 C7
- 2405 C11
- 2406 D10
- 2408 C8
- 2410 D11
- 2412 D2
- 2416 D3
- 2500 C1
- 2526 B2
- 2528 C2
- 2534 B9
- 2535 B9
- 2537 B8
- 2540 C8
- 2541 C4
- 2553 B8
- 2555 C5
- 2556 B7
- 2557 B3
- 2559 C3
- 2568 B11
- 2581 B11
- 2583 A6
- 2584 B3
- 2591 C2
- 2592 B1
- 3100 E6
- 3139 E10
- 3251 E7
- 3304 E7
- 3306 D9
- 3307 D7
- 3315 E7
- 3327 C9
- 3329 D9
- 3406 C11
- 3411 D2
- 3412 E3
- 3440 B3
- 3534 C4
- 3572 A4
- 3573 A5
- 5100 G11
- 5101 G10
- 5102 G8
- 5103 H9
- 5105 G10
- 5200 H7
- 5201 G6
- 5202 G7
- 5203 G5
- 5204 G6
- 5300 E8
- 5302 E8
- 5303 E7
- 5500 B2
- 6216 F2
- 6401 B7
- 6500 A8
- 7109 G11
- 7121 G10
- 7218 G6
- 7231 G5
- 7311 E8
- 7315 F2
- 7321 E2
- 7402 E3
- 8200 H5
- 9199 D7
- 9206 E6
- 9207 A11
- 9208 B9
- 9209 B8
- 9210 C10
- 9211 C10
- 9212 B3
- 9213 C9
- 9215 B10
- 9216 B9
- 9217 B6
- 9218 C3
- 9219 D9
- 9220 A7
- 9221 F2
- 9222 F2
- 9224 C7
- 9225 D7
- 9226 C7
- 9227 C7
- 9228 C7
- 9229 D6
- 9230 D7
- 9231 C5
- 9232 B6
- 9234 C7
- 9235 D6
- 9236 C10
- 9237 D6
- 9238 B4
- 9239 B4
- 9240 C5
- 9241 G6
- 9242 F2
- 9243 C4
- 9244 E8
- 9245 G10
- 9246 G10
- 9247 D4
- 9248 D4
- 9249 E4
- 9250 H4
- 9251 E4
- 9252 E2
- 9254 A4
- 9255 B10
- 9256 D8
- 9258 H8
- 9259 H8
- 9261 F4
- 9262 G4
- 9264 F4
- 9265 F3
- 9266 A4
- 9267 H5
- 9269 B2
- 9270 H9
- 9275 E3
- 9276 H3
- 9277 B5
- 9278 F3
- 9279 E3
- 9281 D5
- 9282 C3
- 9283 D6
- 9285 D4
- 9286 D4
- 9287 C4
- 9289 C2
- 9290 C6
- 9291 C2
- 9292 E2
- 9294 B10
- 9295 A10
- 9296 B10
- 9297 G10
- 9298 B6
- 9299 B6
- 9397 A3
- 9398 C2
- 9399 C3
- 9499 C3
- 9801 C5
- 9802 C4
- 9803 D4
- 9805 A6
- 9806 B6
- 9813 B10
- 9815 A11
- 9816 B11
- 9817 B3
- 9819 C6
- 9820 C3
- 9821 B3
- 9824 G9
- 9825 G7
- 9827 B8

This assembly drawing shows a summary of all possible versions.
 For components used in a specific version see schematic diagram respectively partslist.

COMBI BOARD / componentside view Layout stage .4

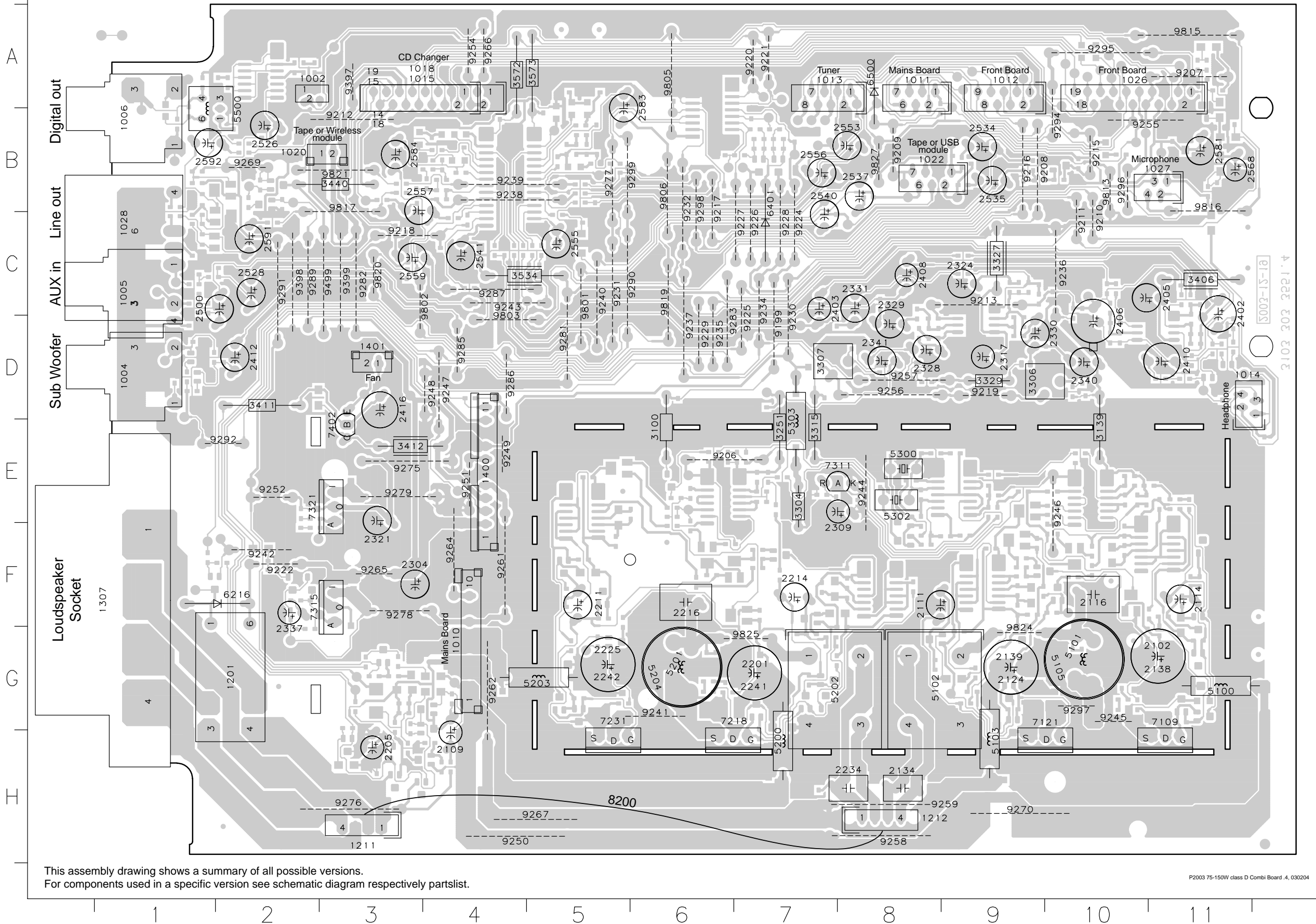

1002	A2	6500	A8
1004	D1	7109	G11
1005	C1	7121	G10
1006	B1	7218	G6
1010	G4	7231	G5
1011	A8	7311	E8
1012	A9	7315	F2
1013	A7	7321	E2
1014	D11	7402	E3
1015	A3	8200	H5
1018	A3	9199	D7
1020	B3	9206	E6
1022	B8	9207	A11
1026	A10	9208	B9
1027	B11	9209	B8
1028	C1	9210	C10
1201	G2	9211	C10
1211	H3	9212	B3
1212	H8	9213	C9
1307	F1	9215	B10
1400	E4	9216	B9
1401	D3	9217	B6
2102	G11	9218	C3
2109	H4	9219	D9
2111	F8	9220	A7
2114	F11	9221	A7
2116	F10	9222	F2
2124	G9	9224	C7
2134	H8	9225	D7
2138	G11	9226	C7
2139	G9	9227	C7
2201	G7	9228	C7
2205	H3	9229	D6
2211	F5	9230	D7
2214	F7	9231	C5
2216	F6	9232	B6
2225	G5	9234	C7
2234	H8	9235	D6
2241	G7	9236	D10
2304	F3	9238	B4
2309	F8	9239	B4
2317	D9	9240	C5
2321	F3	9241	G6
2324	C9	9242	F2
2328	D8	9243	C4
2329	C8	9244	E8
2330	D10	9245	G10
2331	C2	9246	E10
2337	G2	9247	D4
2340	D10	9248	D4
2341	D8	9249	E4
2402	C11	9250	H4
2403	C7	9251	E4
2405	C11	9252	E2
2406	D10	9254	A4
2408	C8	9255	B10
2410	D11	9256	D8
2412	D2	9257	D8
2416	D3	9258	H8
2500	C1	9259	H8
2526	B2	9261	F4
2528	C2	9262	G4
2534	B9	9264	F4
2535	B9	9265	F3
2537	B8	9266	A4
2540	C8	9267	H5
2541	C4	9269	B2
2553	B8	9270	H9
2555	C5	9275	E3
2556	B7	9276	H3
2557	B3	9277	B5
2559	C3	9278	F3
2568	B11	9279	E3
2581	B11	9281	D5
2583	A6	9282	C3
2584	B3	9283	D6
2591	C2	9285	D4
2592	B1	9286	D4
3100	E6	9287	C4
3139	E10	9289	C2
3251	E7	9290	C6
3304	E7	9291	C2
3306	D9	9292	E2
3307	D7	9294	B10
3315	E7	9295	A10
3327	C9	9296	B10
3329	D9	9297	G10
3406	C11	9298	B6
3411	D2	9299	B6
3412	E3	9397	A3
3440	B3	9398	C2
3534	C4	9399	C3
3572	A4	9499	C3
3573	A5	9801	C5
5100	G11	9802	C4
5101	G10	9803	D4
5102	G8	9805	A6
5103	H9	9806	B6
5105	G10	9813	B10
5200	H7	9815	A11
5201	G6	9816	B11
5202	G7	9817	B3
5203	G5	9819	C6
5204	G6	9820	C3
5300	E8	9821	B3
5302	E8	9824	G9
5303	E7	9825	G9
5500	B2	9827	B8
6216	F2		
6401	B7		

This assembly drawing shows a summary of all possible versions.
 For components used in a specific version see schematic diagram respectively partslist.

Mains Board I copperside view

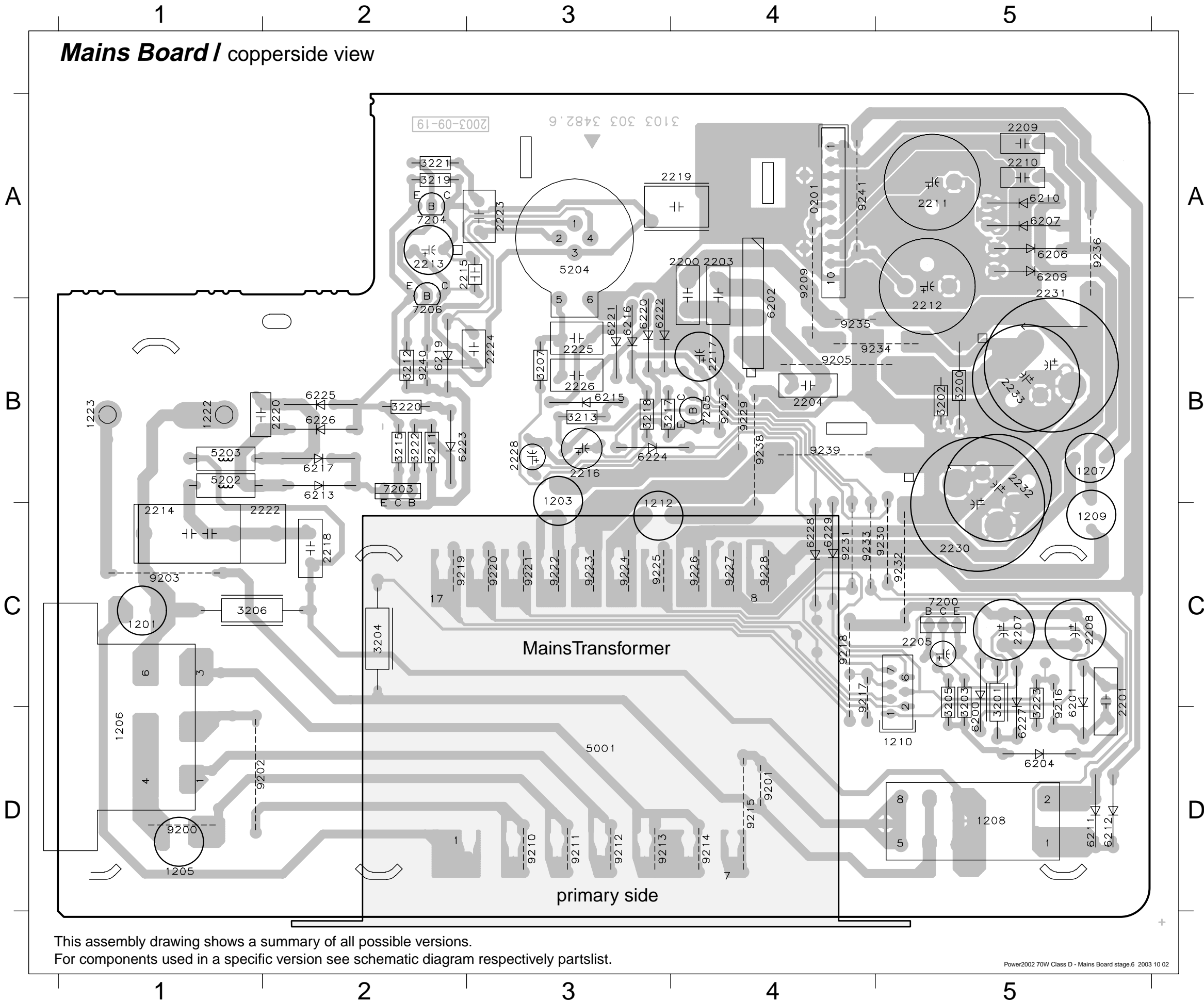

- 0201 A4
- 1201 C1
- 1203 B3
- 1205 D1
- 1206 D1
- 1207 B5
- 1208 D5
- 1209 C5
- 1210 C5
- 1212 C4
- 1222 B4
- 1223 B1
- 2200 A4
- 2201 D5
- 2203 A4
- 2204 B4
- 2205 C5
- 2207 C5
- 2208 C5
- 2209 A5
- 2210 A5
- 2211 A5
- 2212 A4
- 2213 A2
- 2214 B2
- 2215 A3
- 2216 B3
- 2217 B4
- 2218 C2
- 2219 A4
- 2220 B1
- 2221 C1
- 2223 A3
- 2224 B3
- 2225 B3
- 2226 B3
- 2228 B3
- 2230 C5
- 2231 B5
- 2232 B5
- 2233 B5
- 3200 B5
- 3201 D5
- 3202 B5
- 3203 B5
- 3204 C3
- 3205 D5
- 3206 C1
- 3207 B3
- 3211 B2
- 3212 B2
- 3213 B2
- 3215 B2
- 3217 B4
- 3218 B3
- 3219 A3
- 3220 B2
- 3221 A3
- 3222 B3
- 3223 C5
- 5001 C3
- 5202 B1
- 5203 B1
- 5204 A3
- 6200 D5
- 6201 D5
- 6202 B4
- 6204 D5
- 6206 A5
- 6207 A5
- 6209 A5
- 6210 D5
- 6211 D5
- 6212 D5
- 6213 B2
- 6215 B3
- 6216 B3
- 6217 B2
- 6219 B2
- 6221 B3
- 6222 A3
- 6223 B2
- 6224 B3
- 6225 B2
- 6226 C5
- 6227 C5
- 6228 C4
- 6229 C4
- 7200 C5
- 7203 C2
- 7204 A2
- 7205 B3
- 7206 B3
- 9200 D1
- 9201 D4
- 9202 D1
- 9203 C1
- 9205 B4
- 9209 A4
- 9210 D3
- 9211 D3
- 9212 D3
- 9213 D3
- 9214 D4
- 9215 D4
- 9216 D4
- 9217 C4
- 9218 C4
- 9219 C2
- 9220 C3
- 9221 C3
- 9222 C3
- 9223 C3
- 9224 C4
- 9225 C4
- 9226 C4
- 9227 C4
- 9228 C4
- 9229 B4
- 9230 C4
- 9231 C4
- 9232 C5
- 9233 C5
- 9234 B5
- 9235 B4
- 9236 A5
- 9238 B5
- 9239 B4
- 9240 B2
- 9241 A4
- 9242 B4

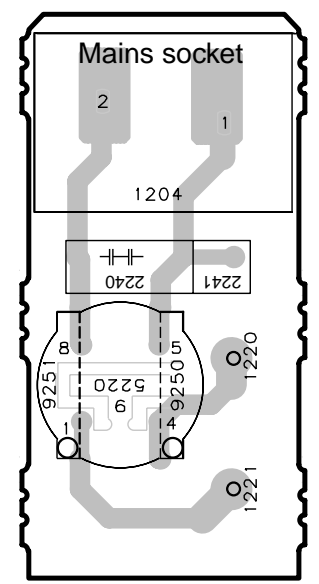

This assembly drawing shows a summary of all possible versions.
 For components used in a specific version see schematic diagram respectively partslist.

0201 D10	1207 B5	1222 A2	2204 A6	2210 C7	2215 D5	2220 E1	2226 D7	2233 A7	3203 B9	3211 D4	3218 B1	3223 B8	6200 B8	6207 C7	6213 D2	6220 D8	6225 E2	7200 A9	9200 A3
1201 A3	1208 C3	1223 A2	2205 A10	2211 C7	2216 E8	2222 D1	2228 C1	2240 A1	3204 A2	3212 D5	3219 E6	5001 A4	6201 C9	6209 C6	6215 D8	6221 E8	6226 E2	7203 D3	9201 B3
1203 A5	1209 C5	2200 A6	2207 B8	2212 B7	2217 E9	2223 D6	2230 A7	3200 A8	3205 B9	3213 D8	3220 E4	5202 E1	6202 A6	6210 C7	6216 D9	6222 E8	6227 B8	7204 E5	9250 A1
1205 A3	1210 C10	2201 C8	2208 B9	2213 D4	2218 E1	2224 E6	2231 B7	3201 B8	3206 B2	3215 E3	3221 D6	5203 E1	6204 B9	6211 C3	6217 D2	6223 E3	6228 C1	7205 B2	9251 A1
1206 A3	1212 B5	2203 A6	2209 C6	2214 D1	2219 E7	2225 C8	2232 A7	3202 A8	3207 C8	3217 C2	3222 E3	5204 D7	6206 C6	6212 C3	6219 D6	6224 C1	6229 C8	7206 D5	

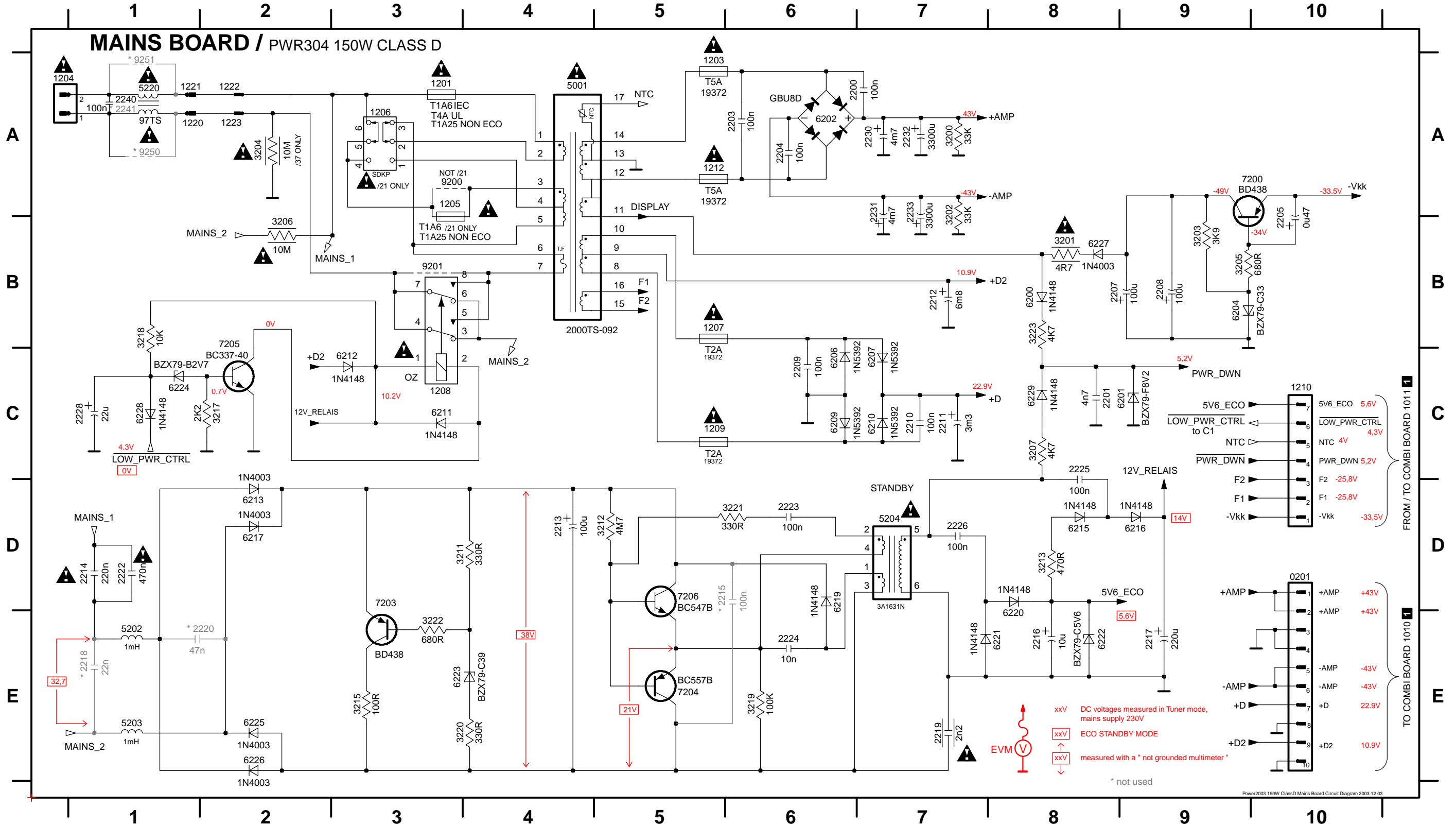

ELECTRICAL PARTSLIST POWER 2003 75&150W Class-D MAINS BOARD

MISCELLANEOUS

Table with 4 columns: Part number, Description, Quantity, and Unit. Includes items like FUSE 1,6A and MAINS SOCKET /37.

Table with 4 columns: Part number, Description, Quantity, and Unit. Includes items like FUSE 1,6A and VOLTAGE SELECTOR.

Table with 4 columns: Part number, Description, Quantity, and Unit. Includes items like FFC-CONNECTOR, 7P, TOP ENTRY and Mains Transformer /37.

Table with 4 columns: Part number, Description, Quantity, and Unit. Includes items like Mains Transformer /37 and STANDBY TRANSFORMER.

CAPACITORS

Table with 5 columns: Part number, Description, Quantity, Tolerance, and Voltage. Includes items like 100nF 10% 100V.

Table with 5 columns: Part number, Description, Quantity, Tolerance, and Voltage. Includes items like 100µF 20% 63V.

Table with 5 columns: Part number, Description, Quantity, Tolerance, and Voltage. Includes items like 100µF 20% 50V.

Table with 5 columns: Part number, Description, Quantity, Tolerance, and Voltage. Includes items like 470nF 10% 275V.

Table with 5 columns: Part number, Description, Quantity, Tolerance, and Voltage. Includes items like 3300µF 20% 50V.

RESISTORS

Table with 5 columns: Part number, Description, Quantity, Tolerance, and Voltage. Includes items like 33kΩ 1% 0,6W.

Table with 5 columns: Part number, Description, Quantity, Tolerance, and Voltage. Includes items like 680Ω 5% 0,5W.

Table with 5 columns: Part number, Description, Quantity, Tolerance, and Voltage. Includes items like 470Ω 5% 0,16W.

Table with 5 columns: Part number, Description, Quantity, Tolerance, and Voltage. Includes items like 330Ω 5% 0,5W.

COILS

Table with 4 columns: Part number, Description, Quantity, and Unit. Includes items like 1000µH.

DIODES

Table with 4 columns: Part number, Description, Quantity, and Unit. Includes items like 1N4148 and BZX79-B8V2.

Table with 4 columns: Part number, Description, Quantity, and Unit. Includes items like 1N4003G and 1N4148.

Table with 4 columns: Part number, Description, Quantity, and Unit. Includes items like 1N4003G and 1N4148.

Table with 4 columns: Part number, Description, Quantity, and Unit. Includes items like BAT85 and BZX79-B39.

Table with 4 columns: Part number, Description, Quantity, and Unit. Includes items like 1N4003G and 1N4148.

TRANSISTORS

Table with 4 columns: Part number, Description, Quantity, and Unit. Includes items like BD438 and BC557B.

ELECTRICAL PARTSLIST POWER 2003 75&150W Class-D COMBI BOARD

MISCELLANEOUS

Table with 4 columns: Part number, Description, Quantity, and Unit. Includes items like SPRING TRANSISTOR and SOCKET, CINCH, 2p.

Table with 4 columns: Part number, Description, Quantity, and Unit. Includes items like FFC CONNECTOR, 4P, TOP ENTRY.

Table with 4 columns: Part number, Description, Quantity, and Unit. Includes item SOCKET, CLICKFIT, 4P.

CAPACITORS

Table with 5 columns: Part number, Description, Quantity, Tolerance, and Voltage. Includes items like 100nF 10% 63V.

Table with 5 columns: Part number, Description, Quantity, Tolerance, and Voltage. Includes items like 1nF 10% 63V.

Table with 5 columns: Part number, Description, Quantity, Tolerance, and Voltage. Includes items like 220pF 5% 50V.

Table with 5 columns: Part number, Description, Quantity, Tolerance, and Voltage. Includes items like 1nF 10% 63V.

Table with 5 columns: Part number, Description, Quantity, Tolerance, and Voltage. Includes items like 1µF 20% 10V.

Table with 5 columns: Part number, Description, Quantity, Tolerance, and Voltage. Includes items like 100nF 10% 50V.

Table with 5 columns: Part number, Description, Quantity, Tolerance, and Voltage. Includes items like 470pF 5% 50V.

Table with 5 columns: Part number, Description, Quantity, Tolerance, and Voltage. Includes items like 100nF 10% 63V.

Table with 5 columns: Part number, Description, Quantity, Tolerance, and Voltage. Includes items like 1nF 10% 63V.

Table with 5 columns: Part number, Description, Quantity, Tolerance, and Voltage. Includes items like 100nF 10% 63V.

Table with 5 columns: Part number, Description, Quantity, Tolerance, and Voltage. Includes items like 100nF 10% 50V.

CAPACITORS

Table with 5 columns: Part number, Description, Quantity, Tolerance, and Voltage. Includes items like 1nF 10% 63V.

Table with 5 columns: Part number, Description, Quantity, Tolerance, and Voltage. Includes items like 4,7nF 10% 63V.

Table with 5 columns: Part number, Description, Quantity, Tolerance, and Voltage. Includes items like 1nF 5% 25V.

Table with 5 columns: Part number, Description, Quantity, Tolerance, and Voltage. Includes items like 330µF 20% 50V.

Table with 5 columns: Part number, Description, Quantity, Tolerance, and Voltage. Includes items like 47µF 20% 16V.

Table with 5 columns: Part number, Description, Quantity, Tolerance, and Voltage. Includes items like 1nF 10% 63V.

Table with 5 columns: Part number, Description, Quantity, Tolerance, and Voltage. Includes items like 100nF 10% 50V.

Table with 5 columns: Part number, Description, Quantity, Tolerance, and Voltage. Includes items like 470pF 5% 50V.

Table with 5 columns: Part number, Description, Quantity, Tolerance, and Voltage. Includes items like 22µF 20% 50V.

Table with 5 columns: Part number, Description, Quantity, Tolerance, and Voltage. Includes items like 100nF 10% 50V.

Table with 5 columns: Part number, Description, Quantity, Tolerance, and Voltage. Includes items like 22µF 20% 50V.

Table with 5 columns: Part number, Description, Quantity, Tolerance, and Voltage. Includes items like 100pF 5% 50V.

Table with 5 columns: Part number, Description, Quantity, Tolerance, and Voltage. Includes items like 470pF 5% 50V.

Table with 5 columns: Part number, Description, Quantity, Tolerance, and Voltage. Includes items like 1µF 20% 10V.

ELECTRICAL PARTSLIST POWER 2003 75&150W Class-D COMBI BOARD

CAPACITORS

2416	4822	124	23052	100μF	20%	16V
2417	4822	124	40150	1μF	20%	10V
2418	4822	2020	552 94427	100pF	5%	50V
2419	4822	2020	552 94427	100pF	5%	50V
2420	4822	3198	017 41050	1μF	20%	10V

2421	4822	2238	586 59812	100nF	10%	50V
2500	4822	2022	020 00734	1μF	20%	50V
2519	4822	2238	586 59812	100nF	10%	50V
2520	4822	126	13881	470pF	5%	50V
2528	4822	2022	020 00734	1μF	20%	50V

2531	4822	126	13881	470pF	5%	50V
2534	4822	124	40769	4,7μF	20%	100V
2535	4822	124	40769	4,7μF	20%	100V
2536	4822	2238	586 59812	100nF	10%	50V
2537	4822	2022	020 00734	1μF	20%	50V

2540	4822	2022	020 00734	1μF	20%	50V
2541	4822	124	81151	22μF	20%	50V
2542	4822	126	11578	1nF	10%	63V
2543	4822	126	14583	470nF	10%	16V
2546	4822	126	14549	33nF	10%	16V

2547	4822	2222	780 15656	330nF	10%	16V
2550	4822	5322	126 11579	3,3nF	10%	63V
2551	4822	126	13879	220nF	20%	16V
2552	4822	126	13193	4,7nF	10%	63V
2553	4822	124	21913	1μF	20%	63V

2554	4822	126	14583	470nF	10%	16V
2555	4822	124	80231	47μF	20%	16V
2556	4822	124	21913	1μF	20%	63V
2557	4822	2022	020 00734	1μF	20%	50V
2558	4822	126	14583	470nF	10%	16V

2559	4822	2022	020 00734	1μF	20%	50V
2560	4822	126	13881	470pF	5%	50V
2561	4822	126	13881	470pF	5%	50V
2562	4822	126	13881	470pF	5%	50V
2563	4822	126	13881	470pF	5%	50V

2564	4822	126	13881	470pF	5%	50V
2565	4822	126	13881	470pF	5%	50V
2566	4822	126	13881	470pF	5%	50V
2567	4822	126	13881	470pF	5%	50V
2568	4822	124	80483	47μF	20%	6,3V

2569	4822	126	14583	470nF	10%	16V
2570	4822	2020	552 94427	100pF	5%	50V
2571	4822	2020	552 94427	100pF	5%	50V
2572	4822	126	13879	220nF	20%	16V
2574	4822	126	13193	4,7nF	10%	63V

2576	4822	5322	126 11578	1nF	10%	63V
2577	4822	126	14549	33nF	10%	16V
2578	4822	5322	126 11579	3,3nF	10%	63V
2579	4822	2020	552 96684	470nF	10%	25V
2581	4822	124	21913	1μF	20%	63V

2582	4822	2238	586 59812	100nF	10%	50V
2585	4822	2238	586 59812	100nF	10%	50V
2593	4822	2222	780 15656	330nF	10%	16V

RESISTORS

3100	4822	050	21003	10kΩ	2%	0,25W
3101	4822	2122	118 06085	0,033Ω	5%	1W
3101	4822	2122	118 06235	0,047Ω	5%	1W
3102	4822	051	30472	4,7kΩ	5%	0,06W
3103	4822	051	30102	1kΩ	5%	0,06W

3106	4822	051	30223	22kΩ	5%	0,06W
3107	4822	051	30152	1,5kΩ	5%	0,06W
3108	4822	051	30472	4,7kΩ	5%	0,06W
3109	4822	051	30101	100Ω	5%	0,06W

RESISTORS

3109	4822	117	13608	4,7Ω	5%	0,06W
3110	4822	117	13632	100kΩ	1%	0,06W
3111	4822	051	30109	10Ω	5%	0,06W
3111	4822	117	12917	1Ω	5%	0,06W
3112	4822	117	12925	47kΩ	1%	0,06W

3113	4822	051	30223	22kΩ	5%	0,06W
3114	4822	051	30472	4,7kΩ	5%	0,06W
3115	4822	051	30102	1kΩ	5%	0,06W
3116	4822	051	30474	470kΩ	5%	0,06W
3117	4822	117	12903	1,8kΩ	1%	0,06W

3119	4822	051	30103	10kΩ	5%	0,06W
3119	4822	051	30153	15kΩ	5%	0,06W
3120	4822	051	30472	4,7kΩ	5%	0,06W
3121	4822	051	30472	4,7kΩ	5%	0,06W
3122	4822	051	30153	15kΩ	5%	0,06W

3125	4822	051	30102	1kΩ	5%	0,06W
3126	4822	051	30103	10kΩ	5%	0,06W
3127	4822	051	30103	10kΩ	5%	0,06W
3129	4822	051	30102	1kΩ	5%	0,06W
3130	4822	2122	118 06085	0,033Ω	5%	1W

3130	4822	2122	118 06235	0,047Ω	5%	1W
3133	4822	051	30562	5,6kΩ	5%	0,06W
3134	4822	051	30331	330Ω	5%	0,06W
3135	4822	051	30101	100Ω	5%	0,06W
3135	4822	117	13608	4,7Ω	5%	0,06W

3136	4822	051	30472	4,7kΩ	5%	0,06W
3137	4822	051	30103	10kΩ	5%	0,06W
3138	4822	051	30103	10kΩ	5%	0,06W
3139	4822	116	52226	560Ω	5%	0,5W
3139	4822	116	83883	470Ω	5%	0,16W

3140	4822	051	30152	1,5kΩ	5%	0,06W
3140	4822	117	11817	1,2kΩ	1%	0,06W
3142	4822	117	11817	1,2kΩ	1%	0,06W
3143	4822	051	30102	1kΩ	5%	0,06W
3144	4822	051	30154	150kΩ	5%	0,06W

3145	4822	117	12139	22Ω	5%	0,06W
3146	4822	051	30152	1,5kΩ	5%	0,06W
3147	4822	051	30103	10kΩ	5%	0,06W
3148	4822	051	30183	18kΩ	5%	0,06W
3149	4822	051	30472	4,7kΩ	5%	0,06W

3151	4822	117	13632	100kΩ	1%	0,06W
3152	4822	051	30152	1,5kΩ	5%	0,06W
3152	4822	117	12903	1,8kΩ	1%	0,06W
3153	4822	051	30152	1,5kΩ	5%	0,06W
3153	4822	117	12903	1,8kΩ	1%	0,06W

3154	4822	051	30102	1kΩ	5%	0,06W
3155	4822	051	30472	4,7kΩ	5%	0,06W
3156	4822	051	30109	10Ω	5%	0,06W
3156	4822	117	12917	1Ω	5%	0,06W
3201	4822	117	12925	47kΩ	1%	0,06W

3202	4822	051	30109	10Ω	5%	0,06W
3202	4822	117	12917	1Ω	5%	0,06W
3203	4822	051	30223	22kΩ	5%	0,06W
3205	4822	2122	118 06085	0,033Ω	5%	1W
3205	4822	2122	118 06235	0,047Ω	5%	1W

3207	4822	051	30474	470kΩ	5%	0,06W
3209	4822	051	30102	1kΩ	5%	0,06W
3210	4822	051	30472	4,7kΩ	5%	0,06W
3211	4822	051	30102	1kΩ	5%	0,06W
3212	4822	051	30472	4,7kΩ	5%	0,06W

3213	4822	051	30102	1kΩ	5%	0,06W
3215	4822	051	30101	100Ω	5%	0,06W
3215	4822	117	13608	4,7Ω	5%	0,06W
3216	4822	051	30223	22kΩ	5%	0,06W

ELECTRICAL PARTSLIST POWER 2003 75&150W Class-D COMBI BOARD

RESISTORS

3217	4822	117	13632	100kΩ	1%	0,06W
3218	4822	051	30472	4,7kΩ	5%	0,06W
3221	4822	051	30103	10kΩ	5%	0,06W
3225	4822	117	12903	1,8kΩ	1%	0,06W
3227	4822	051	30103	10kΩ	5%	0,06W

3228	4822	051	30103	10kΩ	5%	0,06W
3228	4822	051	30153	15kΩ	5%	0,06W
3229	4822	051	30103	10kΩ	5%	0,06W
3231	4822	051	30472	4,7kΩ	5%	0,06W
3232	4822	051	30153	15kΩ	5%	0,06W

3236	4822	117	12139	22Ω	5%	0,06W
3237	4822	051	30103	10kΩ	5%	0,06W
3240	4822	051	30103	10kΩ	5%	0,06W
3241	4822	051	30102	1kΩ	5%	0,06W
3243	4822	2122	118 06085	0,033Ω	5%	1W

3243	4822	2122	118 06235	0,047Ω	5%	1W
3245	4822	051	30562	5,6kΩ	5%	0,06W
3246	4822	051	30331	330Ω	5%	0,06W
3247	4822	051	30101	100Ω	5%	0,06W
3247	4822	117	13608	4,7Ω	5%	0,06W

3248	4822	051	30472	4,7kΩ	5%	0,06W
3251	4822	116	52226	560Ω	5%	0,5W
3251	4822	116	83883	470Ω	5%	0,16W
3252	4822	051	30152	1,5kΩ	5%	0,06W
3252	4822	117	11817	1,2kΩ	1%	0,06W

3253	4822	117	11817	1,2kΩ	1%	0,06W
3254	4822	051	30154	150kΩ	5%	0,06W
3255	4822	051	30102	1kΩ	5%	0,06W
3256	4822	051	30152	1,5kΩ	5%	0,06W
3258	4822	051	30183	18kΩ	5%	0,06W

3259	4822	051	30472	4,7kΩ	5%	0,06W
3261	4822	051	30152	1,5kΩ	5%	0,06W
3262	4822	051	30101	100Ω	5%	0,06W
3263	4822	051	30103	10kΩ	5%	0,06W
3264	4822	117	13632	100kΩ	1%	0,06W

ELECTRICAL PARTSLIST POWER 2003 75&150W Class-D COMBI BOARD

ELECTRICAL PARTSLIST POWER 2003 75&150W Class-D COMBI BOARD

RESISTORS

3509	4822 051 30222	2,2k	5%	0,06W
3510	4822 051 30682	6,8k	5%	0,06W for 150W and 75W SA
3510	4822 051 30223	22k	5%	0,06W for 75W TAPE only
3511	4822 051 30682	6,8k	5%	0,06W for 150W and 75W SA
3511	4822 051 30223	22k	5%	0,06W for 75W TAPE only
3514	4822 051 30153	15k	5%	0,06W
3518	4822 051 30152	1,5k	5%	0,06W
3519	4822 051 30103	10k	5%	0,06W
3520	4822 051 30153	15k	5%	0,06W
3522	4822 051 30152	1,5k	5%	0,06W
3523	4822 051 30152	1,5k	5%	0,06W
3524	4822 117 11817	1,2k	1%	0,06W
3525	4822 051 30102	1k	5%	0,06W
3525	4822 051 30273	27k	5%	0,06W
3526	4822 051 30334	330k	5%	0,06W
3527	4822 051 30102	1k	5%	0,06W
3527	4822 051 30273	27k	5%	0,06W
3529	482 2 051 30154	150k	5%	0,06W
3531	4822 051 30154	150k	5%	0,06W
3532	4822 117 12864	82k	5%	0,06W
3533	4822 051 30562	5,6k	5%	0,06W
3534	4822 052 10109	10	5%	NFR
3535	4822 051 30562	5,6k	5%	0,06W
3536	4822 051 30223	22k	5%	0,06W for 150W and 75W SA
3536	4822 051 30102	1k	5%	0,06W for 75W TAPE only
3539	4822 051 30153	15k	5%	0,06W
3542	4822 051 30123	12k	5%	0,06W
3543	5322 117 13056	8,2k	1%	0,06W
3544	4822 051 30562	5,6k	5%	0,06W
3545	4822 051 30393	39k	5%	0,06W
3549	4822 051 30101	100	5%	0,06W
3550	4822 051 30393	39k	5%	0,06W
3551	4822 051 30101	100	5%	0,06W
3552	4822 051 30101	100	5%	0,06W
3553	4822 051 30101	100	5%	0,06W
3554	4822 051 30101	100	5%	0,06W
3555	4822 051 30562	5,6k	5%	0,06W
3556	4822 051 30153	15k	5%	0,06W
3557	4822 051 30101	100	5%	0,06W
3558	4822 117 12903	1,8k	1%	0,06W
3559	4822 117 12903	1,8k	1%	0,06W
3560	4822 051 30101	100	5%	0,06W
3561	4822 051 30102	1k	5%	0,06W
3562	4822 051 30102	1k	5%	0,06W
3563	4822 051 30101	100	5%	0,06W
3564	4822 051 30101	100	5%	0,06W
3566	4822 051 30101	100	5%	0,06W
3567	4822 051 30101	100	5%	0,06W
3568	4822 051 30101	100	5%	0,06W
3569	4822 051 30102	1k	5%	0,06W
3570	4822 117 13632	100k	1%	0,06W
3571	4822 051 30223	22k	5%	0,06W for 150W and 75W SA
3571	4822 051 30102	1k	5%	0,06W for 75W TAPE only
3572	4822 116 83883	470	5%	0,16W
3573	4822 116 83883	470	5%	0,16W
3574	4822 051 30101	100	5%	0,06W
3575	4822 051 30562	5,6k	5%	0,06W
3576	4822 051 30123	12k	5%	0,06W
3577	4822 051 30153	15k	5%	0,06W
3578	5322 117 13056	8,2k	1%	0,06W
3579	4822 051 30562	5,6k	5%	0,06W
3580	4822 051 30101	100	5%	0,06W
3581	4822 051 30101	100	5%	0,06W

RESISTORS

3591	4822 051 30102	1k	5%	0,06W	for 75W only
3591	4822 051 30332	3,3k	5%	0,06W	for 150W only
4211	4822 051 20008	CHIP JUMPER 0805			
4212	4822 051 20008	CHIP JUMPER 0805			
4213	4822 051 30008	CHIP JUMPER 0603			
4214	4822 051 20008	CHIP JUMPER 0805			
4216	4822 051 30008	CHIP JUMPER 0603			
4217	4822 051 30008	CHIP JUMPER 0603			
4223	4822 051 30008	CHIP JUMPER 0603			
4226	4822 051 30008	CHIP JUMPER 0603			
4230	4822 051 30008	CHIP JUMPER 0603			
4232	4822 051 20008	CHIP JUMPER 0805			
4233	4822 051 30008	CHIP JUMPER 0603			
4235	4822 051 30008	CHIP JUMPER 0603			
4240	4822 051 20008	CHIP JUMPER 0805			
4241	4822 051 20008	CHIP JUMPER 0805			
4245	4822 051 30008	CHIP JUMPER 0603			
4253	4822 051 30008	CHIP JUMPER 0603			
4260	4822 051 20008	CHIP JUMPER 0805			
4265	4822 051 30008	CHIP JUMPER 0603			
4272	4822 051 30008	CHIP JUMPER 0603			
4273	4822 051 30008	CHIP JUMPER 0603			
4274	4822 051 30008	CHIP JUMPER 0603			
4276	4822 051 30008	CHIP JUMPER 0603			
4277	4822 051 30008	CHIP JUMPER 0603			
4279	4822 051 30008	CHIP JUMPER 0603			
4280	4822 051 20008	CHIP JUMPER 0805			
4281	4822 051 30008	CHIP JUMPER 0603			
4282	4822 051 20008	CHIP JUMPER 0805			
4283	4822 051 30008	CHIP JUMPER 0603			
4286	4822 051 30008	CHIP JUMPER 0603			
4287	4822 051 30008	CHIP JUMPER 0603			
4289	4822 051 30008	CHIP JUMPER 0603			
4290	4822 051 30008	CHIP JUMPER 0603			
4301	4822 051 30008	CHIP JUMPER 0603			
COILS					
5100	4822 157 11411	FERRITE BEAD			
5101	2422 536 00612	30μH			for 75W only
5102	2422 549 44944	Mains Filter 330μH 3A			
5103	4822 157 11411	FERRITE BEAD			
5105	2422 536 00686	20μH			for 150W only
5200	4822 157 11411	FERRITE BEAD			
5201	2422 536 00612	30μH			for 75W only
5202	2422 549 44944	Mains Filter 330μH 3A			
5203	4822 157 11411	FERRITE BEAD			
5204	2422 536 00686	20μH			for 150W only
5300	2422 540 98542	Resonator 500kHz			
5302	2422 540 98561	Resonator 425kHz			
5303	4822 157 11411	FERRITE BEAD			
DIODES					
6104	4822 130 11397	BAS316			
6106	4822 130 11416	PDZ6.8B			
6108	4822 130 11416	PDZ6.8B			
6109	4822 130 11397	BAS316			
6110	4822 130 10328	BAV99W			
6111	4822 130 11397	BAS316			
6113	4822 130 10328	BAV99W			
6114	4822 130 10328	BAV99W			
6202	4822 130 11397	BAS316			
6205	4822 130 10328	BAV99W			
6206	4822 130 10328	BAV99W			
6208	4822 130 10328	BAV99W			

DIODES

6210	4822 130 10328	BAV99W			
6211	4822 130 10328	BAV99W			
6212	4822 130 11416	PDZ6.8B			
6213	4822 130 11416	PDZ6.8B			
6214	4822 130 11397	BAS316			
6216	4822 130 30621	1N4148			
6217	4822 130 11397	BAS316			
6300	4822 130 10838	UDZ3.3B			
6401	4822 130 30621	1N4148			
6403	4822 130 10838	UDZ3.3B			
6404	4822 130 11397	BAS316			
6500	4822 130 61219	BZX79-C10			
6501	9322 102 64685	UDZ-2,7B			
6502	4822 130 11397	BAS316			
6503	4822 130 11397	BAS316			
6504	4822 130 11397	BAS316			
6505	4822 130 11397	BAS316			
6506	9322 150 18685	BZX384-C47			
6507	9322 150 18685	BZX384-C47			
6508	3198 020 55680	BZX384-C5V6			
TRANSISTORS					
7104	4822 130 60373	BC856B			
7109	9322 173 29687	STP14NF12FP, FET POWER			for 75W only
7109	9340 578 15127	PHX18NQ11T, FET POWER			for 150W only
7110	3198 010 42310	BC847BW			
7111	3198 010 44350	BC807-25W			
7112	3198 010 42320	BC857BW			
7113	3198 010 44350	BC807-25W			
7114	9340 219 30115	BC817-25W			
7115	9340 219 30115	BC817-25W			
7117	9337 760 90215	PMBTA42			
7119	9337 760 90215	PMBTA42			
7121	9322 173 29687	STP14NF12FP, FET POWER			for 75W only
7121	9340 578 15127	PHX18NQ11T, FET POWER			for 150W only
7128	4822 130 60373	BC856B			
7129	4822 130 60373	BC856B			
7130	3198 010 42310	BC847BW			
7131	5322 130 60159	BC846B			
7132	9340 219 30115	BC817-25W			for 150W only
7133	9340 219 30115	BC817-25W			for 150W only
7203	3198 010 42310	BC847BW			
7208	4822 130 60373	BC856B			
7210	3198 010 44350	BC807-25W			
7211	3198 010 42320	BC857BW			
7218	9322 173 29687	STP14NF12FP, FET POWER			for 75W only
7218	9340 578 15127	PHX18NQ11T, FET POWER			for 150W only
7221	3198 010 44350	BC807-25W			
7222	9340 219 30115	BC817-25W			
7223	9340 219 30115	BC817-25W			
7227	9337 760 90215	PMBTA42			
7228	9337 760 90215	PMBTA42			
7231	9322 173 29687	STP14NF12FP, FET POWER			for 75W only
7231	9340 578 15127	PHX18NQ11T, FET POWER			for 150W only
7238	5322 130 60159	BC846B			
7239	4822 130 60373	BC856B			
7240	4822 130 60373	BC856B			
7243	9340 219 30115	BC817-25W			
7244	9340 219 30115	BC817-25W			for 150W only
7245	9340 219 30115	BC817-25W			for 150W only
7309	3198 010 42310	BC847BW			
7316	3198 010 42320	BC857BW			
7317	3198 010 42310	BC847BW			
7319	3198 010 42310	BC847BW			

TRANSISTORS

7323	9340 219 30115	BC817-25W			
7324	9340 219 30115	BC817-25W			
7402	4822 130 40855	BC337-40			
7405	3198 010 42320	BC857BW			
7407	9340 219 30115	BC817-25W			
7408	9340 219 30115	BC817-25W			
7409	9340 219 30115	BC817-25W			
7410	3198 010 42320	BC857BW			
7411	3198 010 44350	BC807-25W			
7505	3198 010 42310	BC847BW			
7506	3198 010 42320	BC857BW			
7509	3198 010 42310	BC847BW			
INTEGRATED CIRCUITS					
7105	9350 694 90118	74LV14D			
7118	9350 694 90118	74LV14D			
7122	5322 209 11517	PC74HCU04T, HEX INVERTER IC			
7209	9350 694 90118	74LV14D			
7232	5322 209 11517	PC74HCU04T, HEX INVERTER IC			
7235	9350 694 90118	74			

SET MECHANICAL EXPLODED VIEW

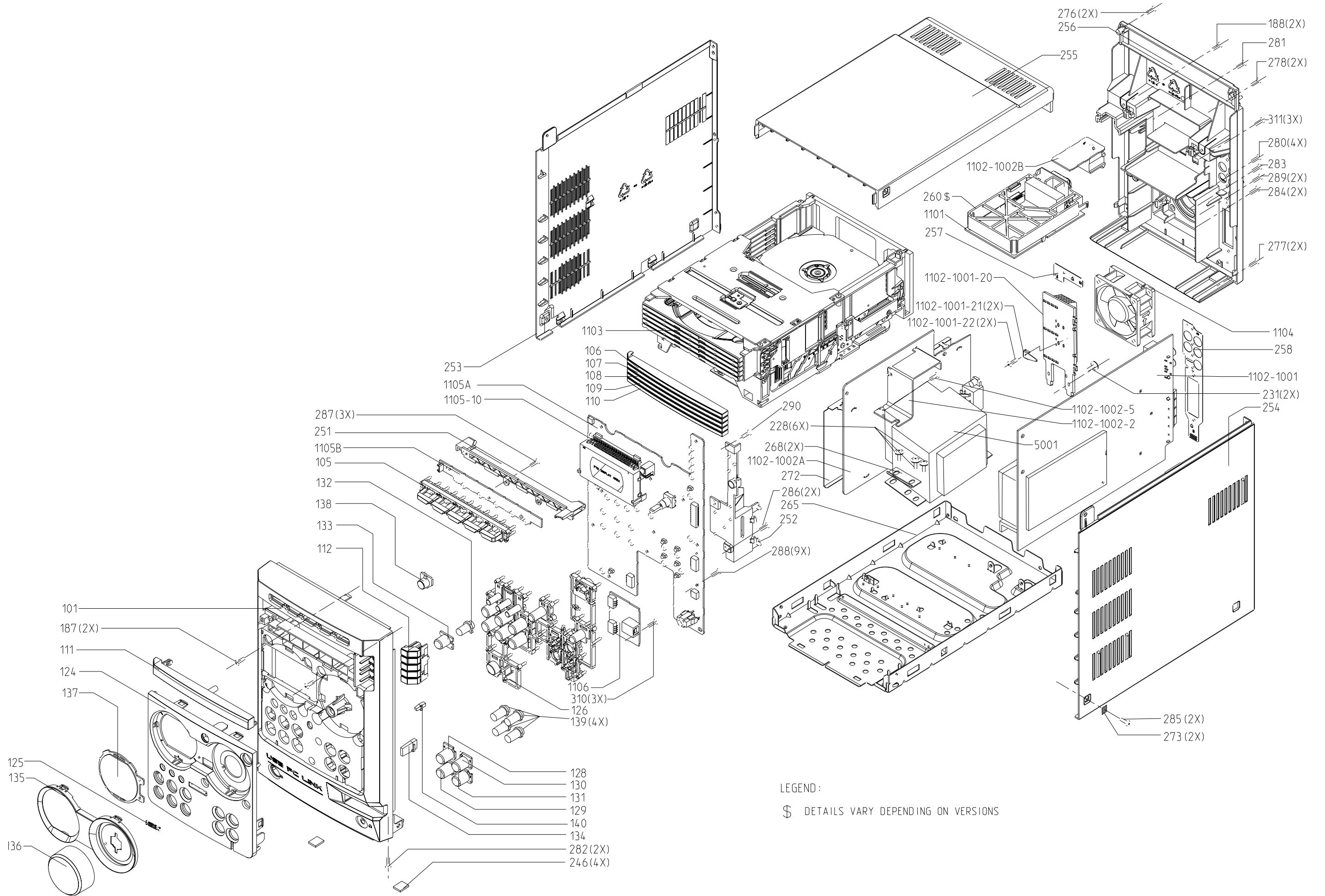

MECHANICAL & ACCESSORIES PARTS LIST - MAIN UNIT

SCREW LISTS - MAIN UNIT

101	3140 117 70941	FRONT CAB PRE-ASS'Y	142	3140 117 71771	COV CD TRAY ASS'Y M590/21	8001	3139 110 35900	FFC Foil 07P/220/07P AD	187	D3 x 10
101	3140 117 70902	FRONT CAB PRE-ASS'Y /22	0001	3140 117 70581	COVER CD TRAY1	8003	3139 111 02551	FFC Foil 15P/480/15P BD Fold	188	D3 x 10
101	3140 117 70551	FRONT CAB PRE-ASS'Y /37	0001	3140 117 71711	COV CD TRAY1 M590/21	8004	3139 111 02541	FFC Foil 08P/280/08P AD Fold	228	M3 x 6
101	3140 117 71681	FRONT CAB PRE-ASS'Y M590/21	0002	3140 117 70591	COVER CD TRAY2	8005	4822 320 12654	FFC Foil 07P/220/07P AD	231	M3 x 6
103	3140 117 70921	CAB FRONT	0002	3140 117 71721	COV CD TRAY2 M590/21	8006	3139 111 02101	FFC Foil 08P/100/08P BD	276	D3 x 12
103	3140 117 70561	CAB FRONT /37	0003	3140 117 70601	COVER CD TRAY3	8007	3139 110 35250	FFC Foil 04P/120/04P AD	277	M3 x 10
103	3140 117 71661	CAB FRONT M590/21	0003	3140 117 71731	COV CD TRAY3 M590/21	8008	3139 111 02371	FFC Foil 19P/180/19P AD Fold	278	D3 x 10
105	3140 117 70571	BUTTON SET CD PLAY	0004	3140 117 70611	COVER CD TRAY4	8009	3139 110 35080	FFC Foil 09P/180/09P AD	280	D3 x 10
112	3140 117 70521	BUTT OPEN/CLOSE	0004	3140 117 71741	COV CD TRAY4 M590/21				281	D3 x 10
112	3140 117 70701	BUT SET CD OP/CL M590/21	0005	3140 117 70621	COVER CD TRAY5				282	M3 x 6
124	3140 117 70632	PANEL FRONT	0005	3140 117 71751	COV CD TRAY5 M590/21					
124	3140 117 70933	PANEL FRONT /22	251	3139 114 77401	BRACKET TOP	8299 297 51040	Grille Assembly		283	D3 x 10
124	3140 117 71781	PANEL FRONT M590/21	252	3139 114 77411	BRACKET COMBI	4399 294 82891	Grommet		284	D3 x 10
125	4822 459 11086	BADGE ASSY PHILIPS	253	3140 114 62611	PANEL LEFT				285	M3 x 10
126	3140 117 70662	BUTT SET CONT	253	3140 114 62531	PANEL LEFT /37				286	D3 x 10
126	3140 117 70681	BUTT SET CONT M590/21	253	3139 114 77242	PANEL LEFT M590/21				287	D3 x 10
128	3139 118 19231	CAP BUTTON CD	254	3140 114 62621	PANEL RIGHT				288	D3 x 10
128	3139 114 77301	CAP BUTTON CD M590/21	254	3140 114 62541	PANEL RIGHT /37				289	D3 x 10
129	3139 118 19241	CAP BUTTON AUX	254	3139 114 77232	PANEL RIGHT M590/21				290	D3 x 12
129	3139 114 77591	CAP BUTTON AUX M590/21	255	3140 114 62631	COVER TOP				310	D3 x 10
130	3139 118 19251	CAP BUTTON TUNER	255	3140 114 62551	COVER TOP /37				311	D3 x 10
130	3139 114 77601	CAP BUTTON TUNER M590/21	255	3139 114 77631	COVER TOP M590/21					
131	3139 118 19261	CAP BUTTON PC LINK	345	3140 118 51771	SPK BOX ASSY					
131	3139 114 77611	CAP BUTTON PC LINK M590/21	345	3140 118 51781	SPK BOX ASSY /37					
133	3139 118 19271	CAP BUTTON MAX	345	3140 118 51801	SPK BOX ASSY M590/21					
138	3139 114 77381	LENS IR	351	2422 076 00546	CBLE FM AERIAL					
246	3139 113 27141	FOOT RUBBER 4MM	351	4822 320 11094	COAXIAL 300R /37					
102	3140 117 70911	REAR CAB PRE-ASS'Y	352	4822 303 50082	AM LOOP ANTENNA					
102	3140 117 70951	REAR CAB PRE-ASS'Y M530/37	353	3140 118 51891	REMOTE CONTROL					
102	3140 119 09251	REAR CAB PRE-ASS'Y M590/21	355	△ 2422 070 98151	MAINSKORD EUR 1M5					
246	3139 113 27141	FOOT RUBBER 4MM	355	△ 2422 070 98248	MAINSKORD AUS/NZ 1M5 /30					
256	3140 114 62641	CAB REAR MICRO	355	△ 2422 070 98246	MAINSKORD UL 7A 1M5 /37					
256	3140 114 62561	CAB REAR MICRO M530/37	357	△ 4822 263 21092	ADAPTOR PLUG 6A 250V /21					
256	3139 114 77251	CAB REAR M590/21	364	3140 110 22491	CABLE USB 3M					
111	3140 117 70441	COVER CD ORN	369	3140 118 72181	CD-ROM USB PC LINK INSTALLER SW					
111	3140 117 71761	COVER CD ORN M590/21	1104	2822 031 01494	FAN 12VDC 0.8W 3100RPM					
135	3140 117 70641	RING VOL & FTD	1106	3103 308 67741	PBAS USB SOUND AGENT					
135	3139 257 50731	RING VOL & FTD M590/21	5001	△ 3103 308 30890	TRAFO CLASS-D 2X70W					
136	3139 118 19281	KNOB VOL	5001	△ 3103 308 30880	TRAFO CLASS-D 2X70W /22					
137	3140 117 71891	LENS FTD	5001	△ 3103 308 30870	TRAFO CLASS-D 2X70W /37					
142	3140 117 70961	COVER CD TRAY ASS'Y	5001	△ 3103 308 30991	TRAFO 2X150W M590/21					

Note : Only the parts mentioned in this list are normal service spare parts.